

ENGINE

INDEX	C - 2
OUTLINE	C - 3
SPECIFICATIONS	C - 3
TROUBLESHOOTING GUIDE	C - 3
ENGINE TUNE-UP PROCEDURE	C - 5
PREPARATION	C - 5
ENGINE OIL	C - 5
ENGINE COOLANT	C - 5
DRIVE BELT	C - 5
COMPRESSION	C - 9
PREPARATION	C - 9
ON-VEHICLE MAINTENANCE	C - 11
REAR OIL SEAL	C - 11
PREPARATION	C - 11
REMOVAL	C - 14
PREPARATION	C - 14
PROCEDURE	C - 14
ENGINE STAND MOUNTING	C - 21
PREPARATION	C - 21
PROCEDURE	C - 21
DISASSEMBLY	C - 23
PREPARATION	C - 23
AUXILIARY PARTS (I)	C - 24
TURBOCHARGER	C - 25
AUXILIARY PARTS (II)	C - 30
HOUSING (EXTERNAL PARTS I)	C - 36
HOUSING (EXTERNAL PARTS II)	C - 39
HOUSING (INTERNAL PARTS)	C - 41
HOUSING (ROTOR)	C - 43
CLEANING	C - 49
PREPARATION	C - 49
INSPECTION / REPAIR	C - 51
PREPARATION	C - 51
ASSEMBLY	C - 60
PREPARATION	C - 60
HOUSING (ROTOR)	C - 61
HOUSING (INTERNAL PARTS)	C - 62
HOUSING (EXTERNAL PARTS II)	C - 73
HOUSING (EXTERNAL PARTS I)	C - 77
AUXILIARY PARTS (II)	C - 86
TURBOCHARGER	C - 92
AUXILIARY PARTS (I)	C - 97
ENGINE STAND DISMOUNTING	C -100
PROCEDURE	C -100
INSTALLATION	C -101
PREPARATION	C -101
PROCEDURE	C -102

INDEX

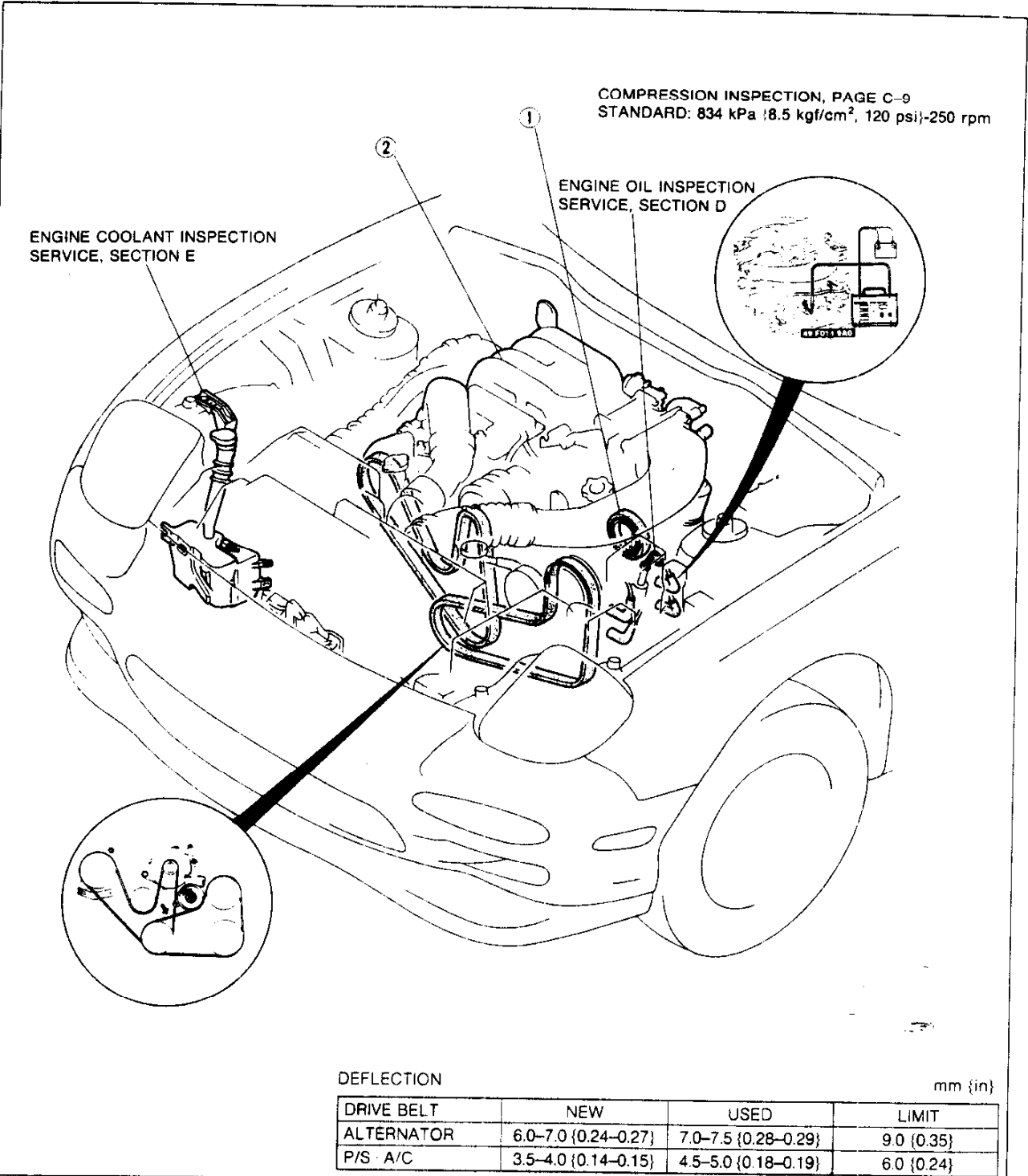

37U0CX-001

1. Rear oil seal Replacement page C- 11

2. Engine
 Removal page C- 14
 Disassembly page C- 23
 Cleaning page C- 49
 Inspection / Repair page C- 51
 Assembly page C- 60
 Installation page C-101

OUTLINE

SPECIFICATIONS

Item		Engine	13B Turbo	
Engine type			Rotary	
Displacement		cm ³ {cu in}	654 × 2 {40.0 × 2}	
Number of cylinders and arrangement			2 rotors, longitudinal	
Combustion chamber type			Bathtub	
Compression ratio			9.0 : 1	
Air induction			4-port induction	
Port timing	Intake	Open	Primary	45° BTDC
			Secondary	32° BTDC
		Close	Primary	50° ABDC
			Secondary	50° ABDC
	Exhaust	Open		75° BBDC
		Close		48° ATDC
Fuel supply system			EGI	
Ignition timing*		Trailing	20°ATDC (-20°BTDC)	
		Leading	5°ATDC (-5°BTDC)	
Idle speed*		rpm	700 - 750	

* TEN terminal of diagnosis connector is grounded.

37UOCX-03

TRUBLESHOOTING GUIDE

Problem	Possible cause	Action	Page
Difficult starting	Insufficient compression		
	Deformation or abnormal wear of side housing	Replace	C-51
	Deformation or abnormal wear of rotor housing	Replace	C-54
	Wear of rotor grooves	Replace	C-57, 58
	Deformation of or loose rotor seals	Replace	C-57, 58
	Worn or weak rotor seal springs	Replace	-
	Malfunction of metering oil pump		Section D
	Malfunction of electrical system		Section F
	Malfunction of electrical system		Section G
Poor idling	Insufficient compression		
	Deformation or abnormal wear of side housing	Replace	C-51
	Deformation or abnormal wear of rotor housing	Replace	C-54
	Wear of rotor grooves	Replace	C-57, 58
	Deformation or loose rotor seals	Replace	C-57, 58
	Worn or weak rotor seal springs	Replace	-
	Malfunction of fuel system		Section F
	Malfunction of ignition system		Section G

37UOCX-034

C

TROUBLESHOOTING GUIDE

Problem	Possible cause	Action	Page
Insufficient power	Insufficient compression Deformation or abnormal wear of side housing Deformation or abnormal wear of rotor housing Wear of rotor grooves Deformation or loose rotor seals Worn or weak rotor seal springs	Replace Replace Replace Replace	C-51 C-54 C-57, 58 C-57, 58
	Malfunction of fuel system		Section F
	Malfunction of ignition system		Section G
Abnormal combustion	Malfunction in combustion chamber Carbon accumulation	Remove and clean	C-49
	Malfunction of fuel system		Section F
	Malfunction of ignition system		Section G
Excessive oil consumption	Leakage into combustion chamber Deformation or abnormal wear of side housing Malfunction of rotor (blow holes) Scratched or burred rotor land Malfunction of oil seal (incorrect angle)	Replace Replace Replace Replace	C-51 C-54 C-54 C-56
	Leakage into coolant passages Deformed rotor housing Malfunction of sealing rubber	Replace Replace	C-54 -
	Leakage to outside of engine		Section D
	Malfunction of lubrication system		Section D
Engine noise	Rotor seal noise Malfunction of rotor seals Malfunction of housing Malfunction of seal spring Malfunction of metering oil pump	Replace Replace Replace	C-56, 57 C-51, 54 C-56, 57 Section D
	Knocking noise Accumulation of carbon	Remove and clean	C-49
	Hitting noise Malfunction of main bearing or rotor bearing Excessive end play Foreign matter in internal gear or stationary gear or malfunction of gear	Replace Adjust Replace	C-53, 56 C-73 C-53
	Other Malfunction of water pump bearing Loose drive belt Malfunction of alternator bearing Exhaust gas leakage Malfunction of fuel system	Adjust	Section E C-5 Section G Section F Section F

37UOCX-005

ENGINE TUNE-UP PROCEDURE

PREPARATION
SST

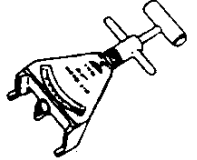
<p>49 9200 020 Tension gauge, V-ribbed belt</p>		<p>For inspection of drive belt tension</p>
---	---	---

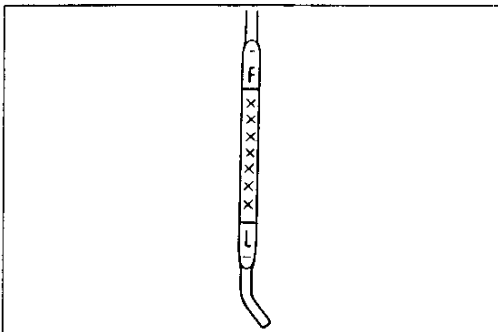

37UOCX-006

16E0B1-006
ENGINE OIL
Inspection

1. Be sure the vehicle is on level ground.
2. Warm up the engine to normal operating temperature and stop it.
3. Wait for five minutes.
4. Remove the oil level dipstick and check the oil level and condition.
5. Add or replace oil if necessary.

Note

- The distance between the L and F marks on the dipstick represents 1.7L {1.8 US qt, 1.5 Imp qt}.

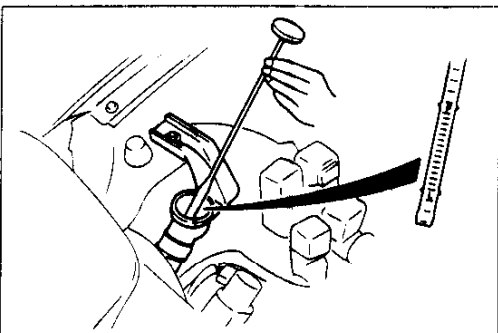

16E0B1-008

ENGINE COOLANT

Inspection

Coolant level (Engine cold)

Warning

- Never remove the radiator cap while the engine is hot.
- Wrap a thick cloth around the cap when removing it.

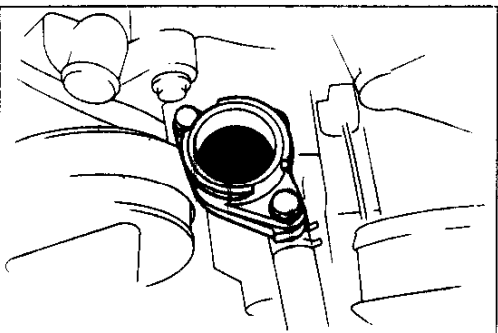

16E0B1-009

1. Verify that the coolant level is near the filler port neck.
2. Remove the coolant level dipstick from the coolant reservoir and verify that the coolant level is between the F and L marks. Add coolant if necessary.

Coolant quality

1. Verify that there is no buildup of rust or scale around the radiator cap and radiator filler neck.
2. Verify that the coolant is free of oil.
3. Replace the coolant if necessary.

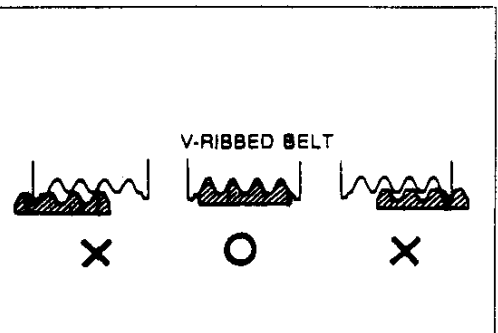

16E0B1-010

DRIVE BELT

Inspection

1. Check the drive belts for wear, cracks, and fraying. Replace if necessary.
2. Verify that the drive belts are correctly mounted on the pulleys.

C

ENGINE TUNE-UP PROCEDURE

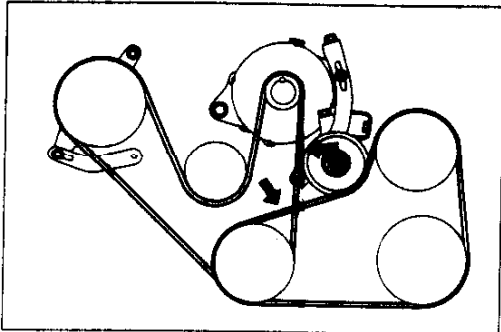

37U0CX-007

3. Check the drive belt deflection by applying moderate pressure **98 N {10 kgf, 22 lbf}** midway between the pulleys.

Note

- Measure the belt deflection between the specified pulleys.
- A belt is considered "New" if it has been used on a running engine for less than 5 minutes. Set the deflection specified below accordingly.
- Check the belt deflection when the engine is cold, or at least 30 minutes after the engine has stopped.

Deflection

mm { in }

Drive belt	New	Used	Limit
Alternator	6.0-7.0 {0.24-0.27 }	7.0-7.5 {0.28- 0.29 }	9.0 {0.35}
P/S-A/C	3.5-4.0 {0.14-0.15}	4.5-5.0 {0.18-0.19}	6.0 {0.24}

4. If the deflection is not within specification, adjust it.

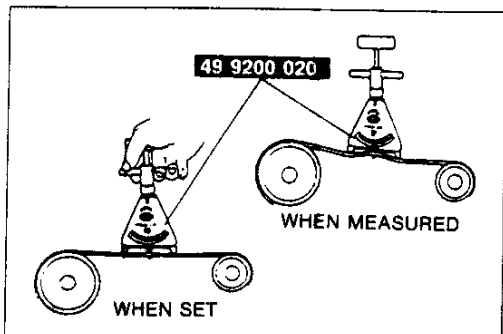

37U0CX-008

Drive belt tension check

Note

- Belt tension can be checked in place of belt deflection.
- Belt tension can be measured between any two pulleys.

1. Using the **SST**, check the belt tension.

Tension

N {kgf/lbf}

Drive belt	New	Used	Limit
Alternator	690-780 {70-80, 160-170}	590-680 {60-70, 140-150}	320 {33, 73}
P/S-A/C	740-880 {75-90, 170-190}	540-630 {55-65, 130-140}	320 {33, 73}

2. If the tension is not within specification, adjust it.

Adjustment

Caution

- A belt is considered "New" if it has been used on a running engine for less than 5 minutes.

Alternator

1. Loosen bolt A and nut B.
2. Adjust the belt deflection by turning adjusting bolt C.

Deflection

- New** : 6.0-7.0 mm {0.24-0.27 in}
- Used** : 7.0-7.5 mm {0.28-0.29 in}
- Limit** : 9.0 mm {0.35 in}

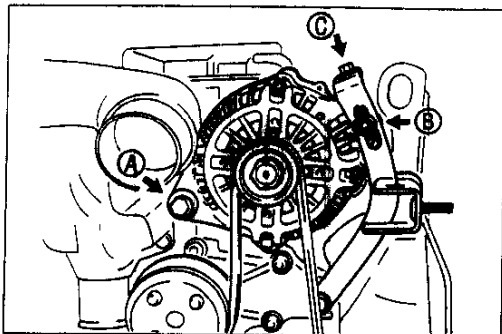

37U0CX-009

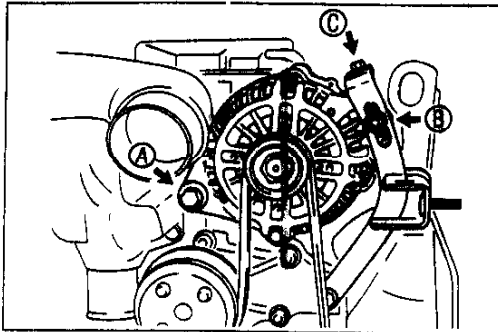

37U0CX-010

3. Tighten bolt A, and nut B.

Tightening torque:

Bolt A 38-51 N·m {3.8-5.3 kgf·m, 28-38 ft·lbf}

Nut B 19-25 N·m {1.9-2.6 kgf·m, 14-18 ft·lbf}

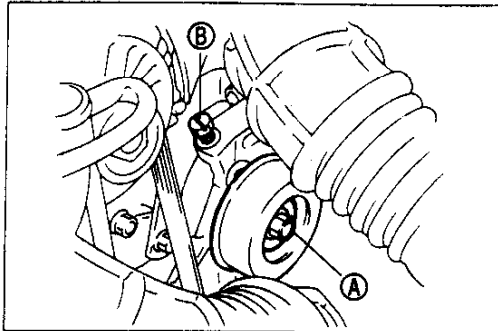

37U0CX-011

P/S, A/C

1. Loosen nut A.
2. Adjust the belt deflection by turning adjusting bolt B.

Deflection

New : 3.5-4.0 mm {0.14-0.15 in}

Used: 4.5-5.0 mm {0.18-0.19 in}

Limit: 6.0 mm {0.24 in}

3. Tighten nut A.

Tightening torque:

37-53 N·m {3.7-5.5 kgf·m, 27-39 ft·lbf}

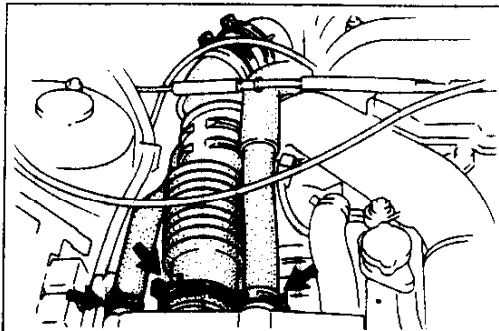

37U0CX-012

Replacement

P/S, A/C

1. Disconnect the air hoses shown in the figure.

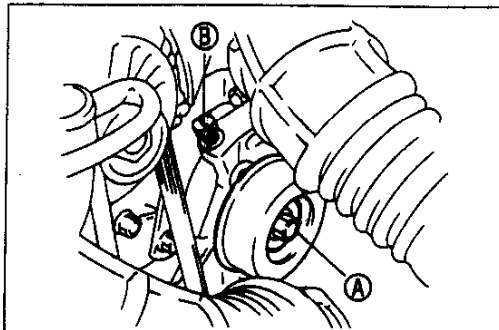

37U0CX-013

2. Loosen idler pulley locknut A.
3. Loosen adjusting bolt B.
4. Remove the belt.

C

ENGINE TUNE-UP PROCEDURE

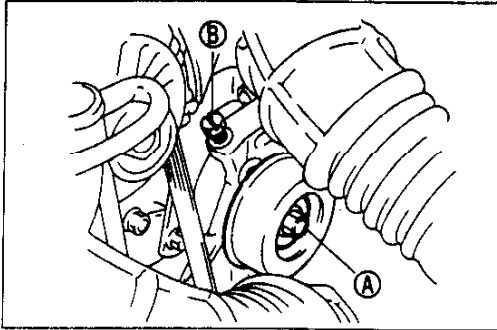

37U0CX-014

5. Install the new belt on the pulleys.
6. Adjust the belt deflection by turning adjusting bolt B.

Deflection

3.5–4.0mm {0.14–0.15 in}

7. Tighten pully locknut A.

Tightening torque:

37–53 N·m {3.7–5.5 kgf·m, 27–39 ft·lbf}

8. Connect the air hoses.

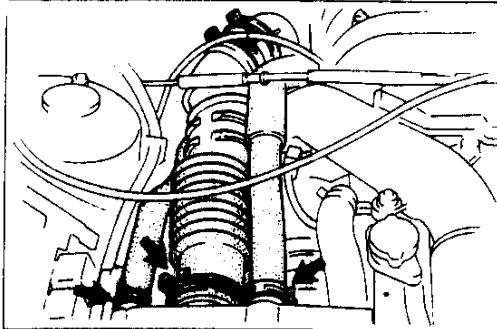

37U0CX-015

Alternator

1. Disconnect the air hoses shown in the figure.

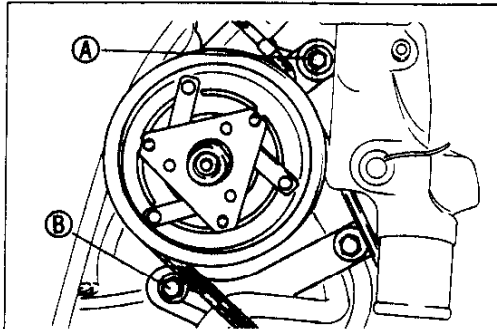

37U0CX-016

2. Loosen air pump mount bolts A and B.

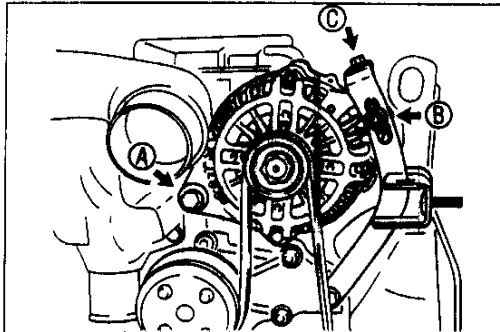

37U0CX-017

3. Loosen alternator mount bolt A and locknut B.
4. Loosen adjusting bolt C.
5. Remove the drive belt.

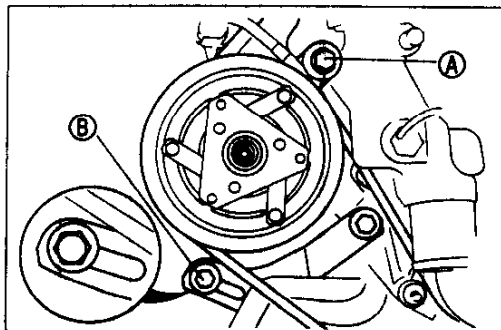

37U0CX-018

6. Install the new drive belt on the pulleys.
7. Install the air pump while applying the pressure the drive belt.

Tightening torque:

19–25 N·m {1.9–2.6 kgf·m, 14–18 ft·lbf}

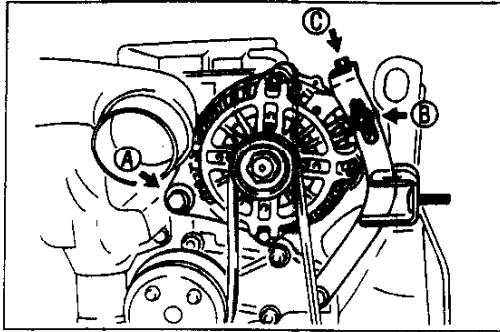

37U0CX-019

8. Adjust the belt deflection by turning adjusting bolt C.

Deflection

6.0–7.0 mm {0.24–0.27 in}

9. Tighten alternator mount bolt A and locknut B.

Tightening torque:

Bolt A 37–51 N·m {3.8–5.3 kgf·m, 28–38 ft·lbf}

Nut B 19–25 N·m {1.9–2.6 kgf·m, 14–18 ft·lbf}

10. Connect the air hoses.

COMPRESSION

If the engine exhibits low power, poor fuel economy, or poor idle, check the following:

1. Ignition system (Refer to Section G.)
2. Compression
3. Fuel system (Refer to Section F.)

37U0CX-020

PREPARATION

SST

49 F018 9A0		For Inspection of compression
Tester, compression		

37U0CX-013

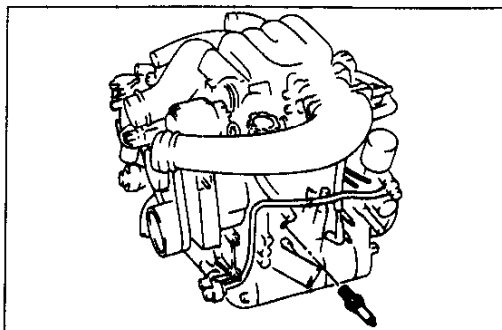

37U0CX-022

1. Check that the battery is fully charged. Recharge it if necessary.
2. Warm up the engine to the normal operating temperature, then stop it.
3. Allow about 10 minutes for the exhaust manifold to cool.
4. Remove the front and rear trailing-side spark plugs.
5. Disconnect the circuit-opening relay and the igniter connector.

COMPRESSION

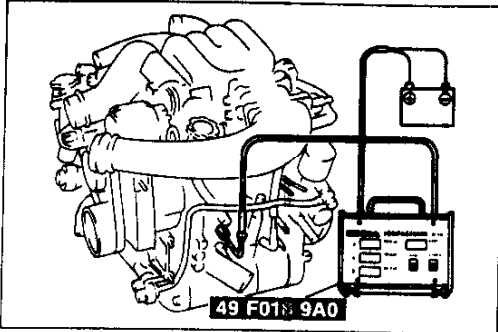

37U0CX-023

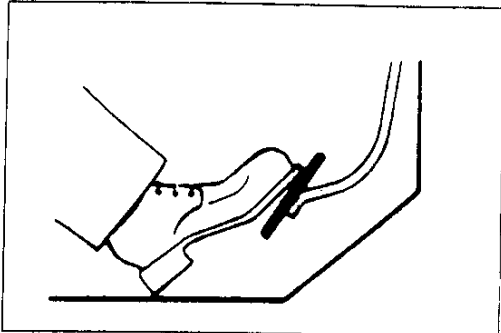

37U0CX-024

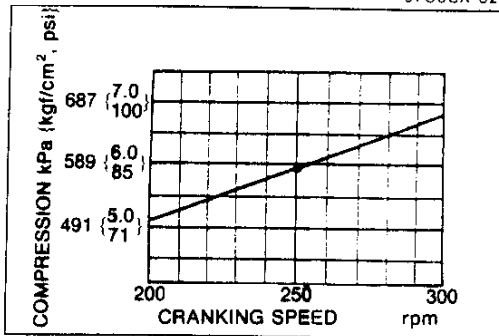

970CX-017

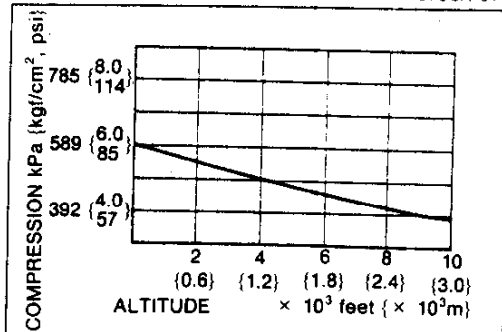

970CX-018

6. Connect the **SST** to the front rotor housing and the battery.
7. Fully depress the accelerator pedal and crank the engine for 5 to 10 seconds.
8. Make a note of the compression of the three combustion chambers and cranking speed.

Compression:

590 kPa {6.0 kgf/cm², 85 psi}-250 rpm

Differential limit of chambers:

150 kPa {1.5 kgf/cm², 21 psi}-250 rpm

Note

- 1) If pressure below 290 kPa {3.0 kgf/cm², 43 psi} exists in one or two chambers of a rotor, the tester indicates one correct measurement and two 00.0 readings.
 - 2) If three chamber pressure are below 290 kPa {3.0 kgf/cm², 43 psi}, the tester indicates three 00.0 readings.
 - 3) In the above cases, the cranking speed readings are all 00.0.
9. Check the rear chambers by using the same procedure.

Note

- Compensate for the compression values if they are measured at cranking speeds different than standard or if they are measured at a high altitude.

Cranking speed compensation



Compensate for the cranking speed.

Altitude compensation

Compensate for the altitude.

ON-VEHICLE MAINTENANCE

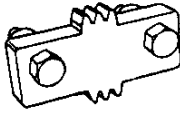
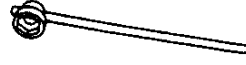
REAR OIL SEAL
PREPARATION
SST

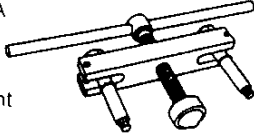
<p>49 F011 101</p> <p>Brake, ring gear</p> 	<p>For prevention of eccentric shaft rotation</p>	<p>49 0820 035</p> <p>Box wrench, flywheel</p> 	<p>For removal of flywheel locknut</p>
<p>49 1881 055A</p> <p>Stopper, counterweight</p> 	<p>For prevention of eccentric shaft rotation</p>	<p>49 0839 305A</p> <p>Puller, counterweight</p> 	<p>For removal of counterweight</p>

37U0CX-025

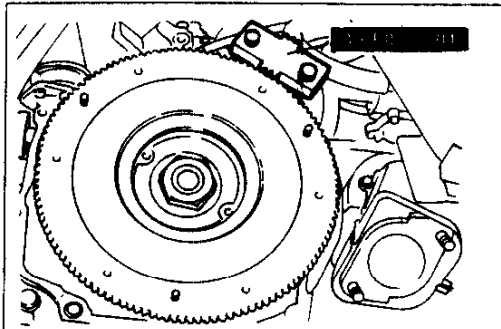

37U0CX-026

Removal Note

1. Disconnect the negative battery cable.
2. Drain the engine oil.
3. Remove the manual transmission. (Refer to Section J.)
Remove the automatic transmission. (Refer to Section K.)
4. Remove the clutch cover and clutch disc. (Refer to Section H.)

(MT)

5. Install the **SST** against the flywheel.

Caution

- Place a rag between the **SST** and the vacuum pipes to protect the pipes.

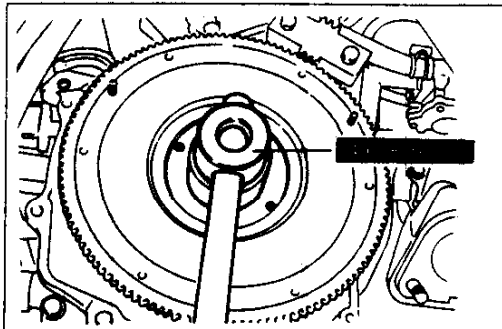

97U0CX-021

6. Remove the locknut by using the **SST**.

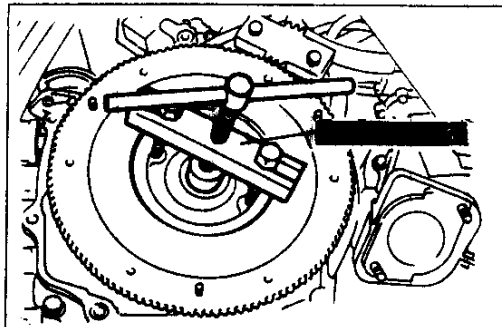

97U0CX-022

7. Remove the flywheel by using the **SST**.
8. Remove the key.

C

ON-VEHICLE MAINTENANCE

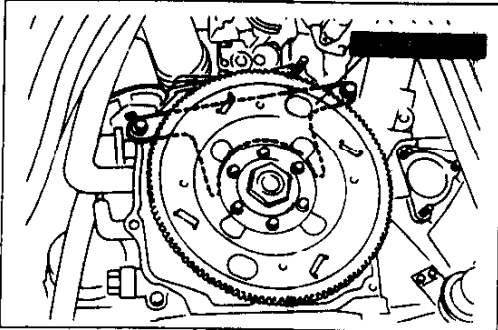

97U0CX-023

(AT)

5. Install the **SST** against the counterweight.

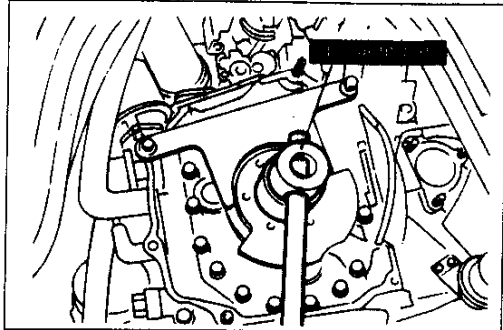

97U0CX-024

6. Remove the back plate and drive plate.

7. Remove the locknut by using the **SST**.

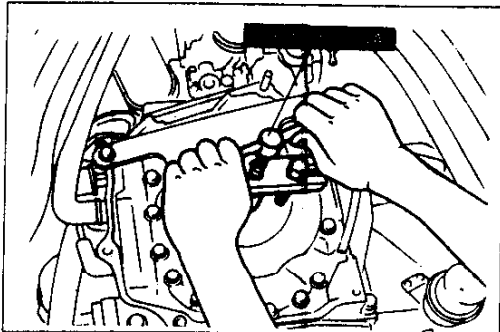

97U0CX-025

8. Remove the counterweight by using the **SST**.

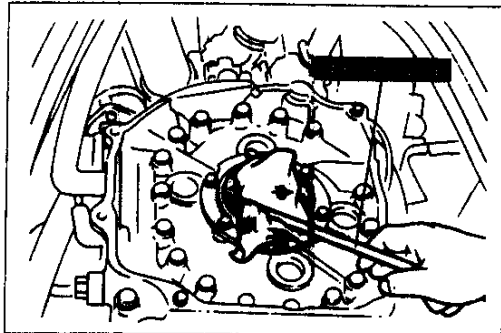

17U0CX-022

(MT and AT)

9. Remove the oil seal by using the **SST**.

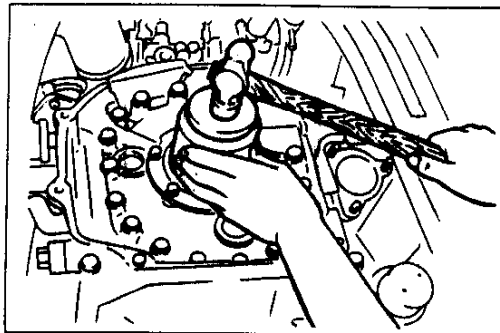

37U0CX-027

Installation Note

Rear oil seal

1. Apply engine oil to the seal lip.
2. Fit the oil seal onto the stationary gear.
3. Tap the oil seal in evenly using a suitable pipe.

Oil seal outer diameter: 95.0 mm {3.74 in}

Caution

- The oil seal must be tapped in until it is flush with the edge of the rear cover.

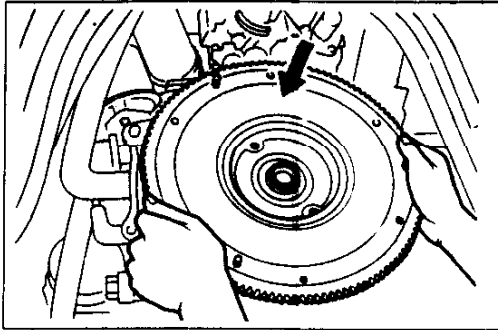

97U0CX-028

Flywheel (MT)

1. Fit the key to the eccentric shaft.
2. Install the flywheel to the eccentric shaft.
3. Apply thread-locking compound to the eccentric shaft threads.
4. Apply sealant to the contact surface of the locknut.

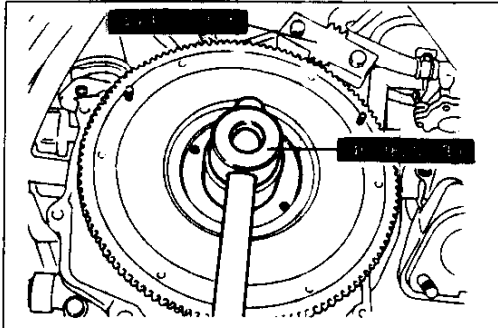

37U0CX 028

5. Install the locknut and tighten it with the **SST**.

Tightening torque:

400–490 N·m {40–50 kgf·m, 290–360 ft·lbf}

Caution

- Place a rag between the SST and the vacuum pipes to protect pipes.

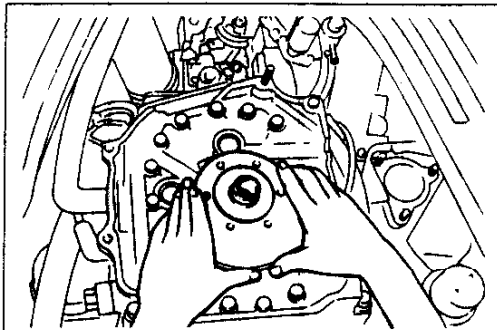

97U0CX-030

Drive plate (AT)

1. Fit the key to the eccentric shaft.
2. Install the counterweight to the eccentric shaft.
3. Apply thread-locking compound to the eccentric shaft threads.
4. Apply sealant to the contact surface of the locknut.

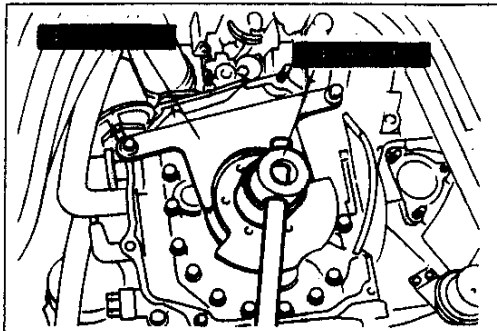

37U0CX-029

5. Install the locknut and tighten it with the **SST**.

Tightening torque:

400–490 N·m {40–50 kgf·m, 290–360 ft·lbf}

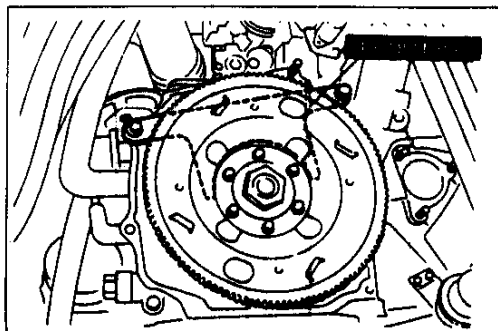

37U0CX-030

6. Install the drive plate and the back plate.

Tightening torque:

44–60 N·m {4.4–6.2 kgf·m 32–44 ft·lbf}

Steps After Installation

1. Add engine oil to the specified level.
2. Connect the negative battery cable.
3. Start the engine and do the following:
 - (1) Check for leakage of engine oil.
 - (2) Perform engine adjustments as necessary.
 - (3) Recheck the oil level.

C

REMOVAL

REMOVAL

PREPARATION

SST

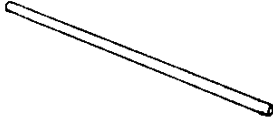
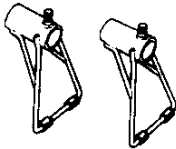
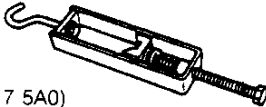
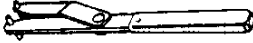
<p>49 G017 5A0 Support, engine</p> 	<p>For support of engine</p>	<p>49 G017 501 Bar (Part of 49 G017 5A0)</p> 	<p>For support of engine</p>
<p>49 G017 502 Support (Part of 49 G017 5A0)</p> 	<p>For support of engine</p>	<p>49 G017 503 Hook (Part of 49 G017 5A0)</p> 	<p>For support of engine</p>
<p>49 W023 585A Adjust wrench</p> 	<p>For prevention of P/S oil pump rotation</p>	<p>37U0CX-011</p>	

PROCEDURE

Warning

● Release the fuel pressure. (Refer to Section F)

1. Disconnect the negative battery cable.
2. Drain the engine coolant and engine oil.
3. Remove the undercover.
4. Remove the transmission. (Refer to Section J or K.)
5. Disconnect the engine control unit. (Refer to Section F.)
6. Remove in the order shown in the figure, referring to **Removal Note**.

37U0CX-032

Step 1

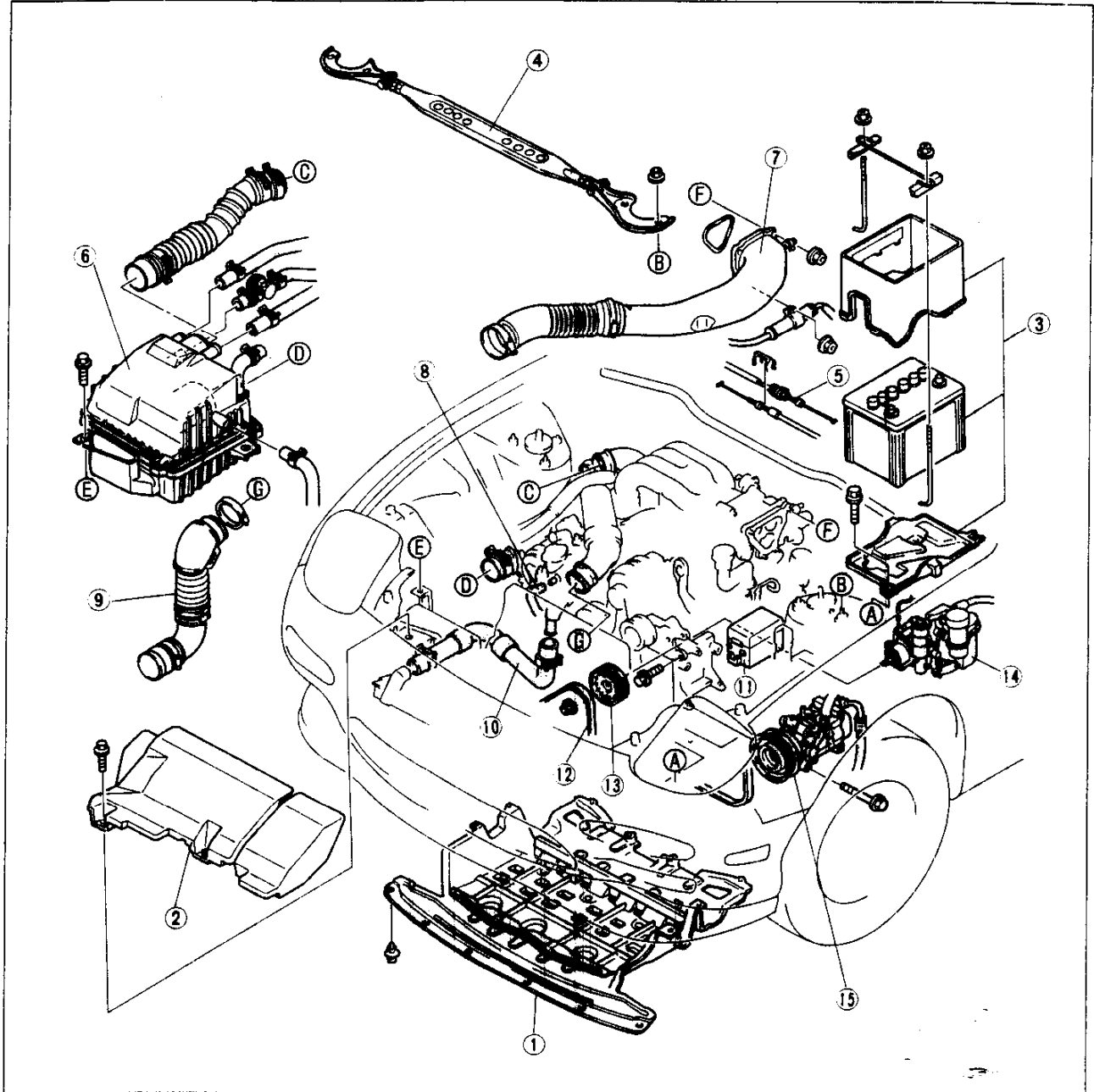

37UOCX-(33

- | | |
|---------------------------|-----------|
| 1. Undercover | |
| 2. Fresh air duct | |
| 3. Battery and box | |
| 4. Strut bar | |
| Removal Note | page C-16 |
| 5. Accelerator cable | |
| 6. Air cleaner assembly | |
| 7. Hose | |
| 8. Water hose | |
| 9. Air hose | |
| 10. Radiator hose (upper) | |
| 11. Fuse box | |
| Removal Note | page C-16 |
| 12. Drive belt | |
| Removal Note | page C-25 |
| 13. P/S oil pump pulley | |
| Removal Note | page C-16 |
| 14. P/S oil pump | |
| Removal Note | page C-16 |
| 15. A/C compressor | |
| Removal Note | page C-16 |

C

REMOVAL

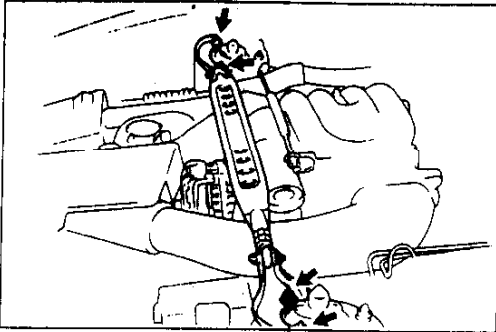

37U0CX-034

Removal Note Strut bar

1. Remove the strut bar.
2. Temporarily tighten the locknut to the stud bolt.

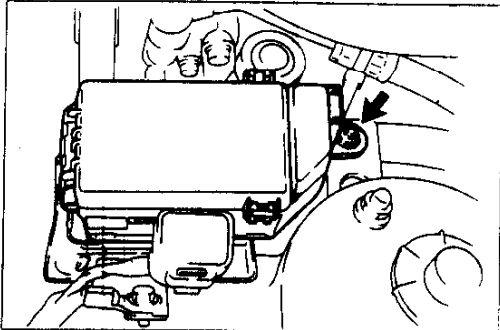

37U0CX-035

Fuse box

Remove the fuse box with the harness still connected.

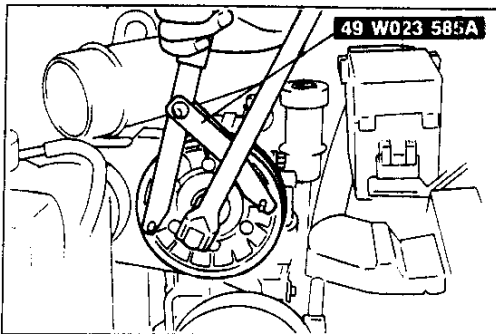

37U0CX-036

P/S Oil pump pulley

1. Hold the P/S oil pump pulley by using the **SST**.
2. Remove the P/S oil pump pulley nut.
3. Remove the P/S oil pump pulley.

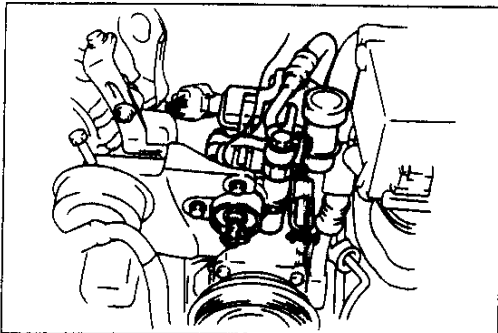

37U0CX-037

P/S oil pump

Caution

- Do not damage the hoses.

1. Remove the P/S oil pump with the hose still connected.
2. Position the pump away from the engine, and support it with wire.

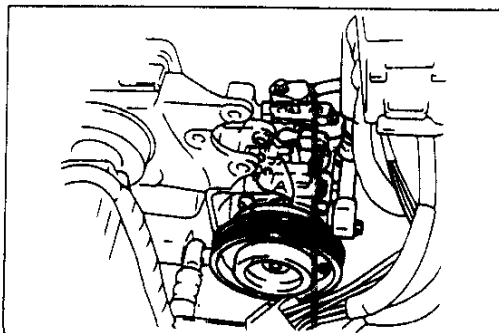

37U0CX-038

A/C Compressor

Caution

- Do not damage the hoses.

1. Remove the A/C compressor with the hoses still connected.
2. Position the compressor away from the engine, and support it with wire.

Step 2
Disconnect the harness connectors and hoses.

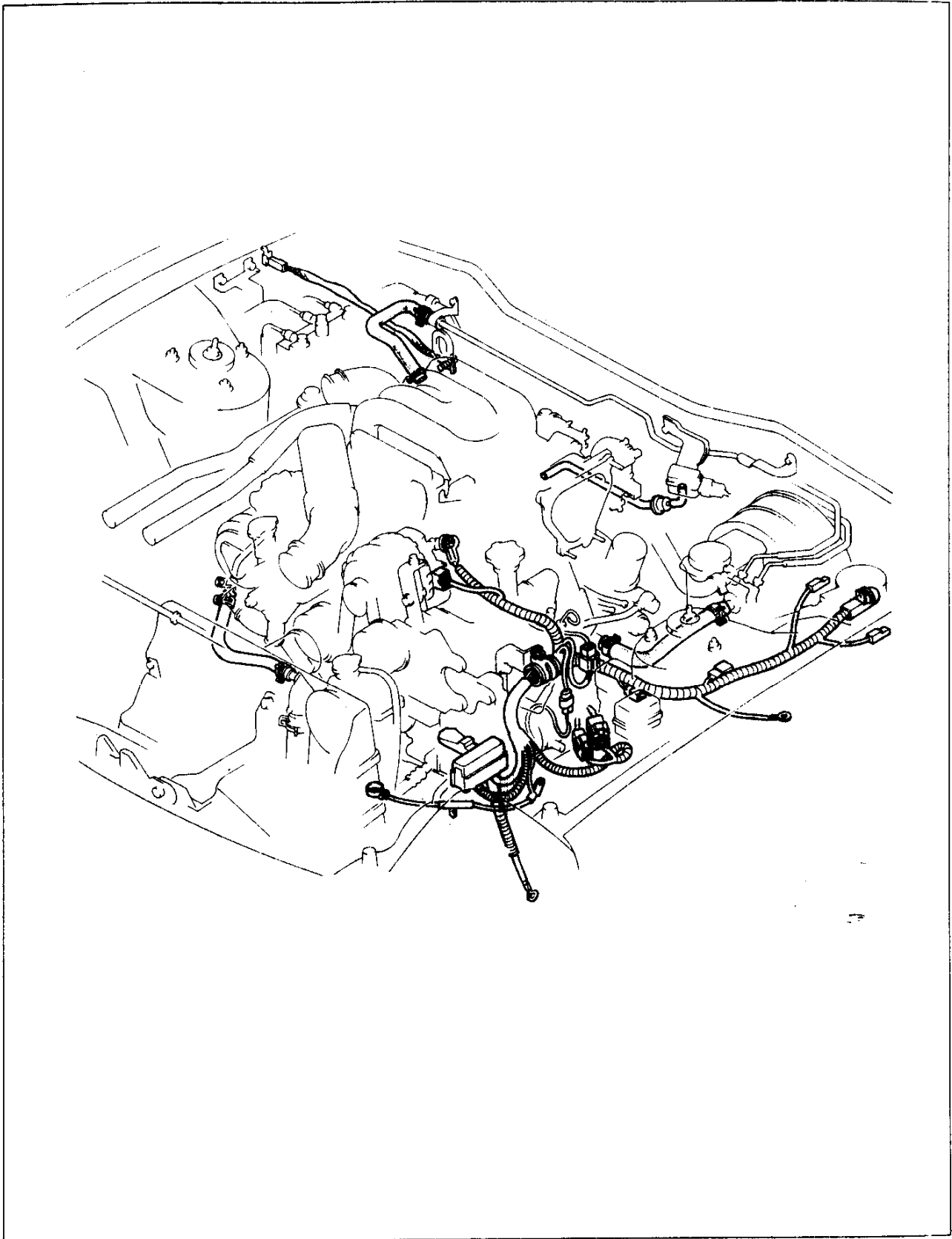

37U0CX-339

C

REMOVAL

Step 3

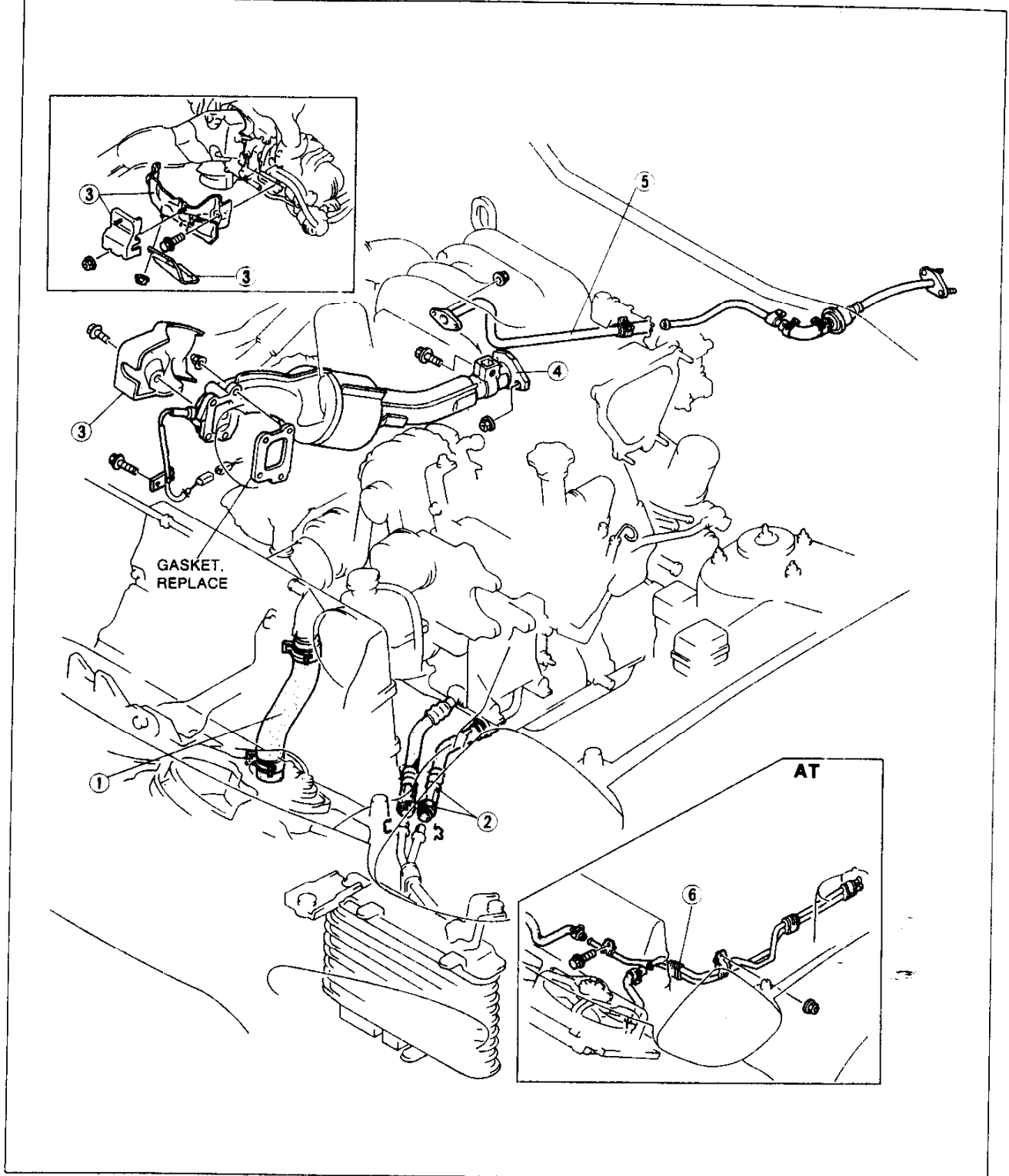

37U0CX-04 J

1. Radiator hose (lower)

2. Oil pipe

Removal Note page C-19

3. Insulator

Removal Note page C-19

4. Front exhaust pipe

Removal Note page C-19

5. Split air pipe

6. Oil cooler pipe (AT)

Removal Note page C-19

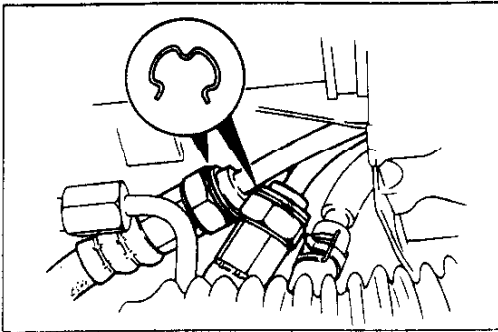

37U0CX-041

Removal Note

Oil pipe

Remove the clip and disconnect the oil pipe.

Caution

- Use a drain pan to catch the oil when the oil pipe is disconnected.

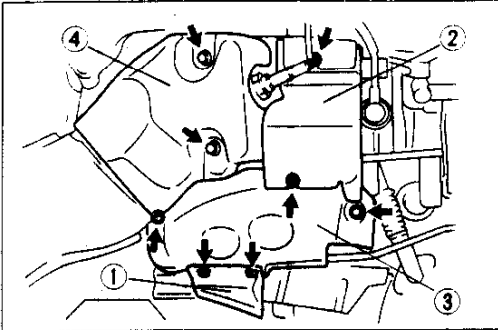

37U0CX-042

Insulator

Remove the insulators in the order shown in the figure.

Caution

- Do not allow oil on the insulators.

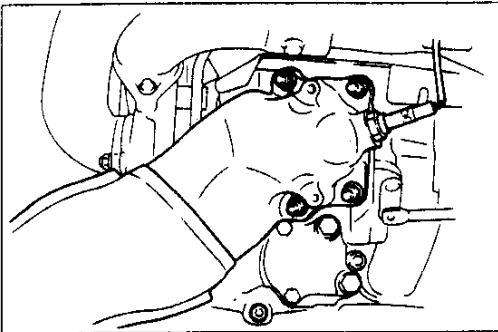

37U0CX-043

Front exhaust pipe

1. Disconnect the oxygen sensor harness.
2. Remove the front exhaust pipe.

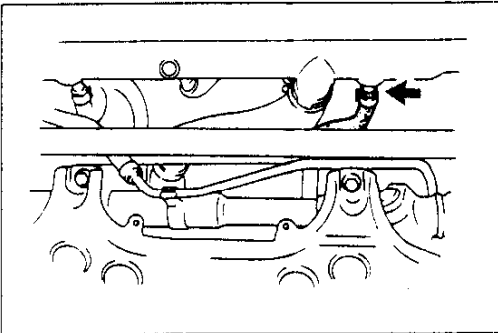

37U0CX-044

Oil cooler pipe (AT)

1. Disconnect the oil cooler pipe.

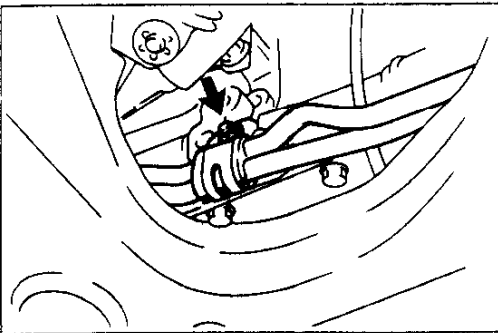

37U0CX-045

2. Remove the nut shown in the figure.

C

REMOVAL

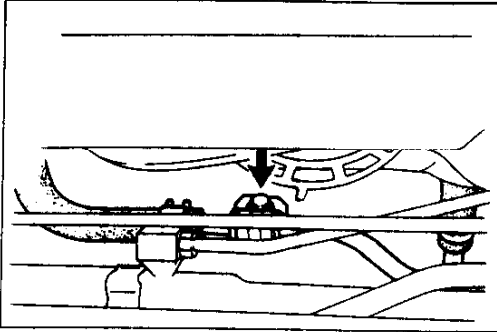

37UOCX-046

3. Remove the bolt shown in the figure and disconnect the oil cooler pipe from the engine.



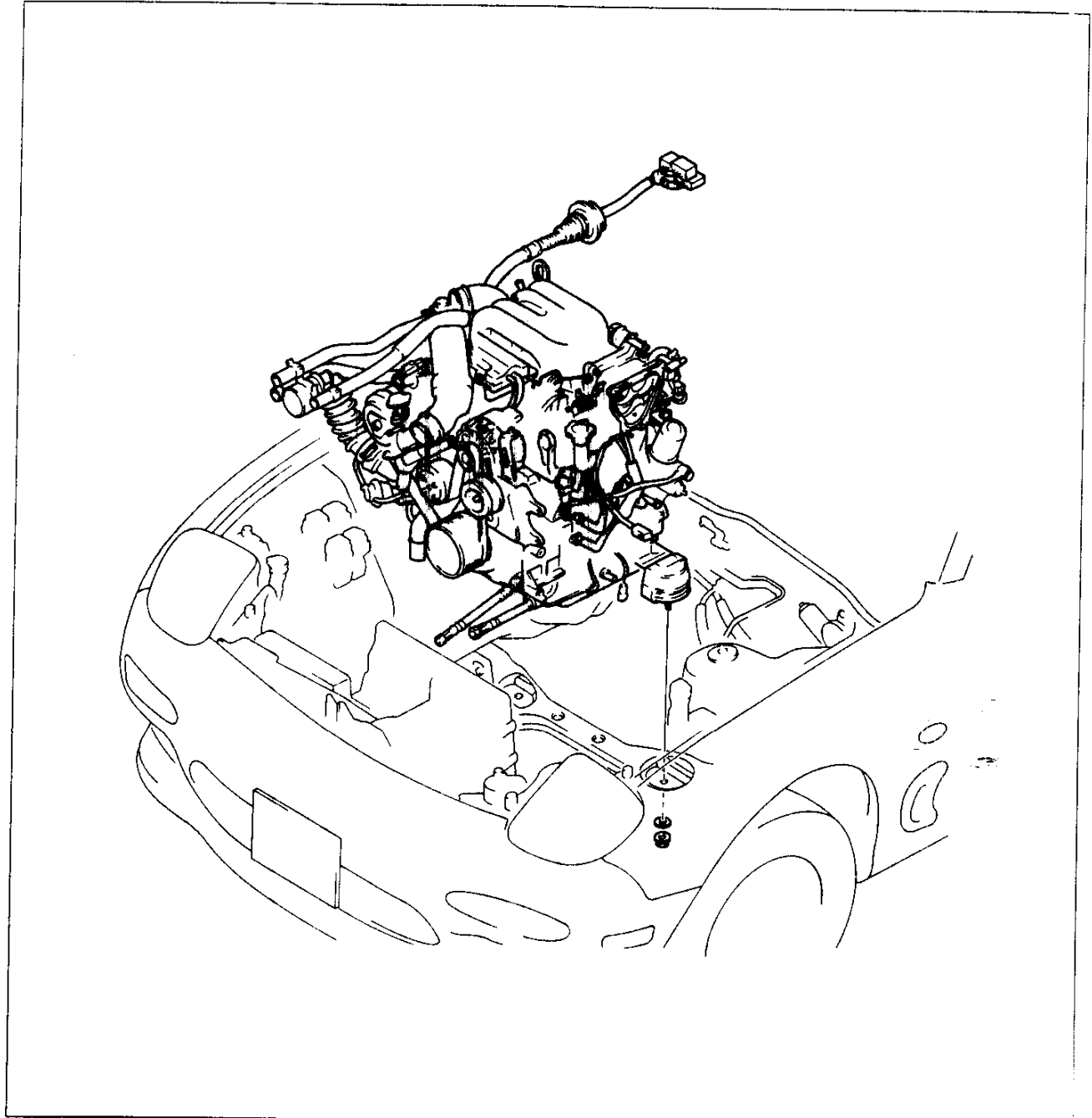



Step 4

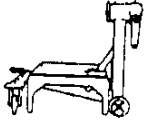

37UOCX-047

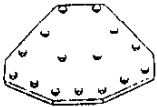
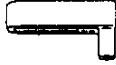
ENGINE STAND MOUNTING

PREPARATION
SST

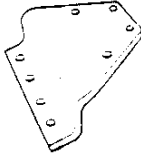
<p>49 O107 680A</p> <p>Stand, engine</p> 	<p>For disassembly / assembly of engine</p>	<p>49 L010 1A0</p> <p>Hanger set, engine stand</p> 	<p>For disassembly / assembly of engine</p>
<p>49 L011 101</p> <p>Plate</p> <p>(Part of 49 L011 1A0)</p> 	<p>For disassembly / assembly of engine</p>	<p>49 L010 102</p> <p>Arms</p> <p>(Part of 49 L010 1A0)</p> 	<p>For disassembly / assembly of engine</p>
<p>49 L010 103</p> <p>Hooks</p> <p>(Part of 49 L011 1A0)</p> 	<p>For disassembly / assembly of engine</p>	<p>49 L010 104</p> <p>Nuts</p> <p>(Part of 49 L010 1A0)</p> 	<p>For disassembly / assembly of engine</p>
<p>49 L010 105</p> <p>Bolts</p> <p>(Part of 49 L010 1A0)</p> 	<p>For disassembly / assembly of engine</p>	<p>49 L010 106</p> <p>Bolts</p> <p>(Part of 49 L010 1A0)</p> 	<p>For disassembly / assembly of engine</p>
<p>49 1114 005</p> <p>Hanger, engine</p> 	<p>For disassembly / assembly of engine</p>	<p>37U0CX-048</p>	

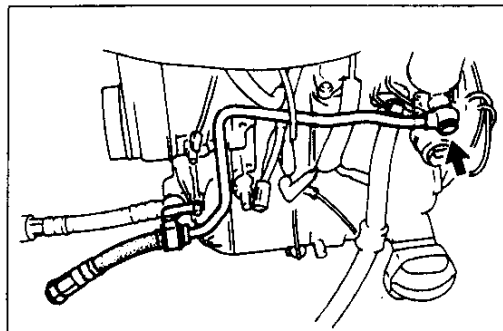

37U0CX-049

PROCEDURE
When using 49 L010 1A0

1. Remove the oil pipe.

C

ENGINE STAND MOUNTING

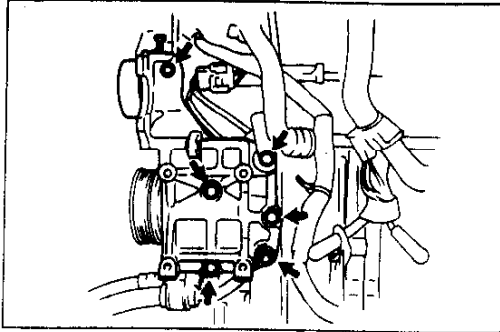

37U0CX-050

2. Remove the A/C compressor and P/S oil pump bracket.
3. Remove the stud.

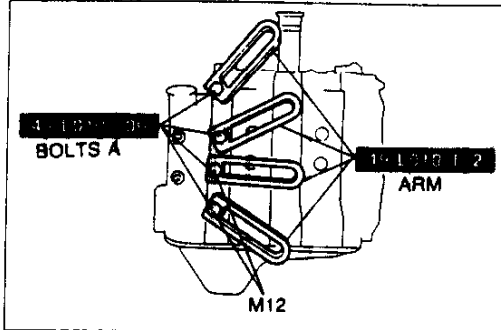

37U0CX-051

4. Install the **SST** (arms) to the block holes shown in the figure and loosely tighten bolts A.

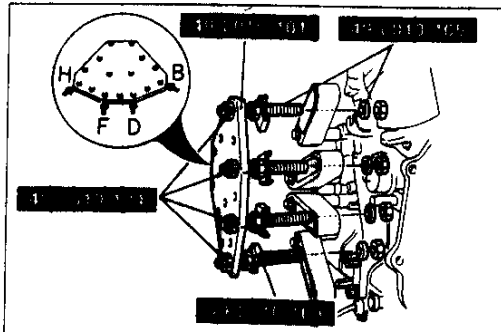

97U0CX-045

5. Assemble the **SST** (bolts, nuts, hooks and plate).
6. Install the **SST** assembly to the respective arms while adjusting parallelism between the arms and plate by turning the bolts and nuts.

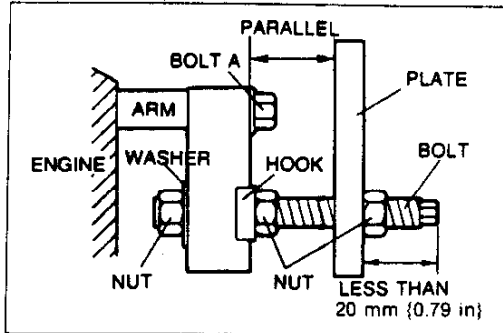

97U0CX-046

Warning

- Use special caution while turning the engine stand handle to prevent hand injury.

7. Tighten the bolts and nuts to affix the **SST**.

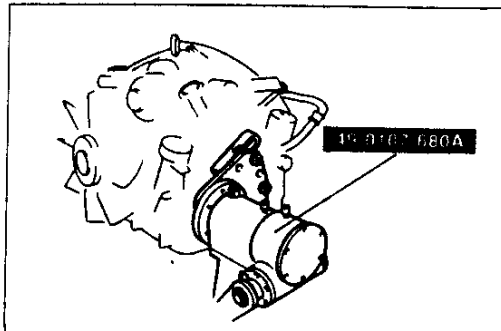

97U0CX-047

8. Install the engine on the **SST** (engine stand).

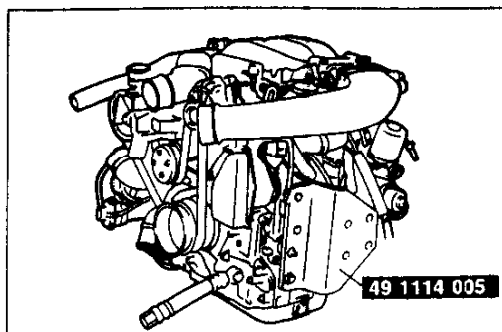

37U0CX-052

When using 49 1114 005

1. Remove the engine mounts, A/C compressor, and P/S oil pump bracket.
2. Install the **SST** as shown in the figure.

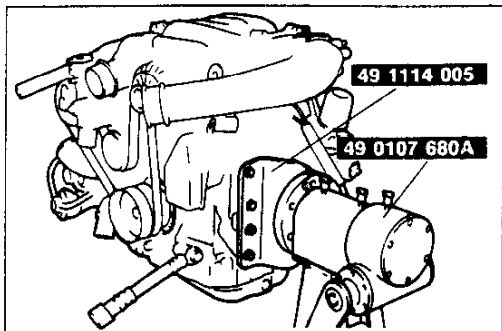



37U0CX-053

3. Mount the engine on the **SST** (engine stand).

DISASSEMBLY

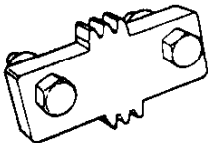
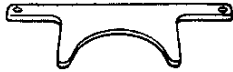
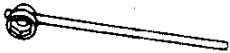
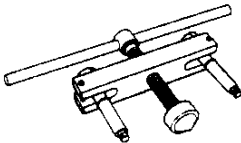
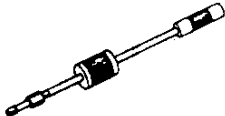
**PREPARATION
SST**

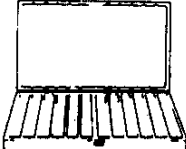
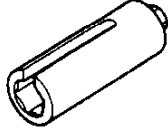
<p>49 F011 101</p> <p>Brake, ring gear</p> 	<p>For prevention of engine rotation</p>	<p>49 1881 055A</p> <p>Stopper, counterweight</p> 	<p>For prevention of engine rotation</p>
<p>49 0820 035</p> <p>Box wrench flywheel</p> 	<p>For removal/ installation of locknut</p>	<p>49 0839 305A</p> <p>Puller counterweight</p> 	<p>For removal of counterweight</p>
<p>49 0813 215A</p> <p>Puller, tubular dowel</p> 	<p>For removal of tubular dowel</p>	<p>49 0813 225</p> <p>Remover, oil seal</p> 	<p>For removal of oil seal</p>
<p>49 0813 250</p> <p>Case, seal</p> 	<p>For arrangement of rotor seals</p>	<p>49 H018 001</p> <p>Wrench, knock sensor</p> 	<p>For removal of knock sensor</p>

37U0CX-054

C

DISASSEMBLY

1. Code all identical parts (such as rotors, rotor oil seals, rotor seals, and seal springs) so that they can be reinstalled in the location from which they were removed.
2. Clean the parts with a steam cleaner; blow off any remaining water with compressed air.

Note

- During the disassembly of any part or system, be sure to study its order of assembly. Also, note any deformation, wear, or damage.

AUXILIARY PARTS (I)

97U0CX-049

1. Drain the engine oil.
2. Disassemble in the order shown in the figure, referring to **Disassembly Note**.

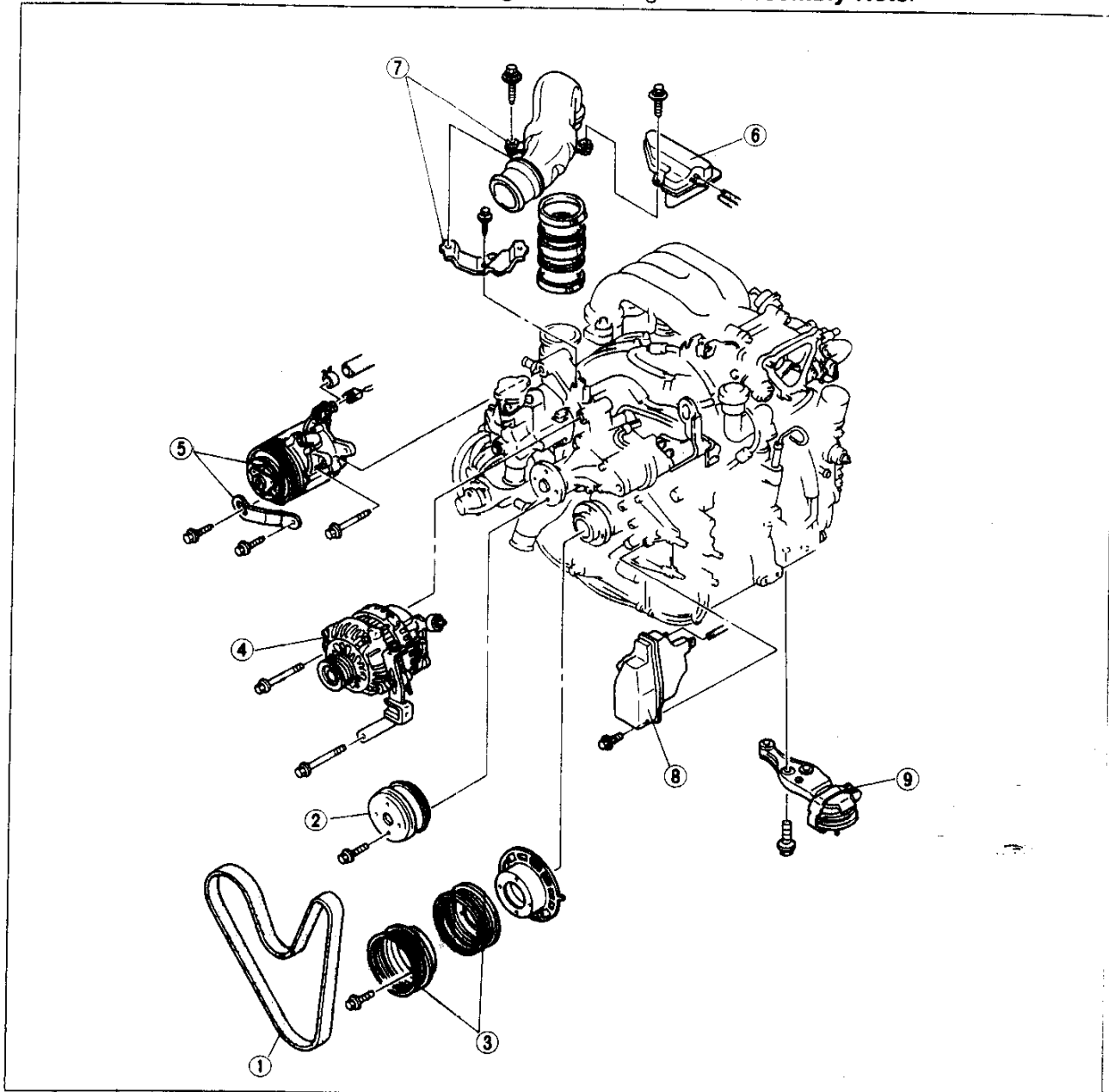

37U0CX-055

1. Drive belt
Disassembly Note page C-25
2. Water pump pulley
3. Drive belt pulley

4. Alternator and bracket
5. Air pump and bracket
6. Pressure chamber
7. Air pipe and bracket
8. Vacuum chamber
9. Engine mount (RH and LH)

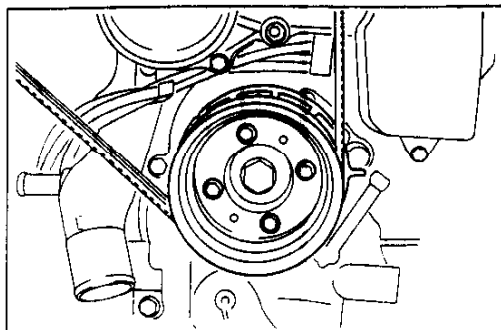

37U0CX-056

Disassembly Note Drive belt

1. Loosen the water pump pulley lock bolts and drive belt pulley bolts.

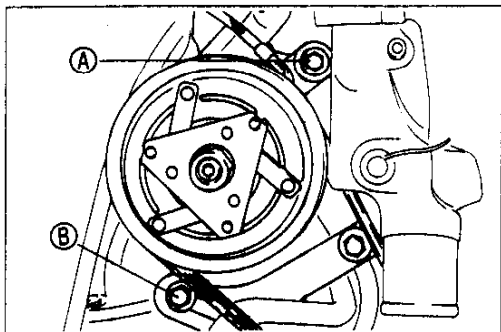

37U0CX-057

2. Loosen air pump lock bolts A and B.

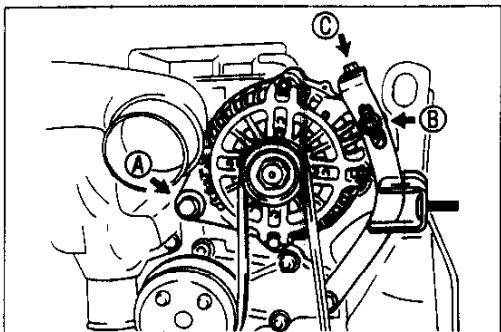

37U0CX-058

3. Loosen alternator lock bolt A and nut B.

4. Loosen adjusting bolt C.

5. Remove the drive belt.

TURBOCHARGER

Caution

- When removing and carrying the turbocharger, do not hold the actuator, rod or actuator hose.
- If studs are damaged, replace them with the specified studs and nuts. Using unspecified studs may cause gas leakage because of insufficient clamping.
- As the turbocharger operates at high speed and high temperature, use care to prevent deformation of the oil pipe and entry of any foreign material into the oil line.
- Tape the turbocharger air port and exhaust port to prevent entry of any foreign material.
- Do not deform the insulators, and do not allow oil on them.

37U0CX-059

C

DISASSEMBLY

Disassemble in the order shown in the figure, referring to **Disassembly Note**.

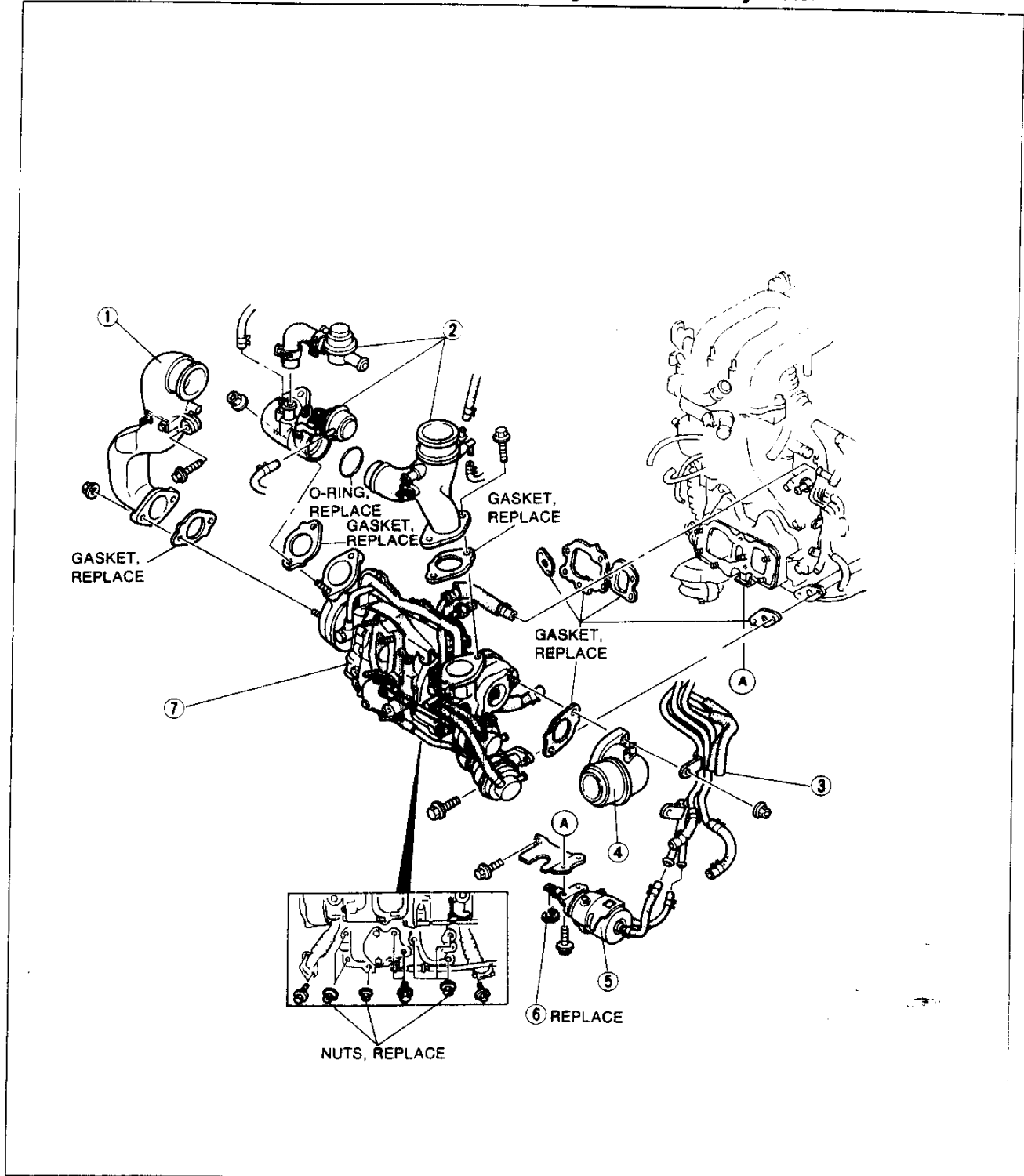

37U0CX-060

- 1. Air pipe
- 2. Air pipe and control valve
Disassembly Note page C-27
- 3. Vacuum pipe
Disassembly Note page C-27

- 4. Air intake pipe
- 5. Turbo control actuator
Disassembly Note page C-27
- 6. Clip
- 7. Turbocharger assembly
Disassembly Note page C-28

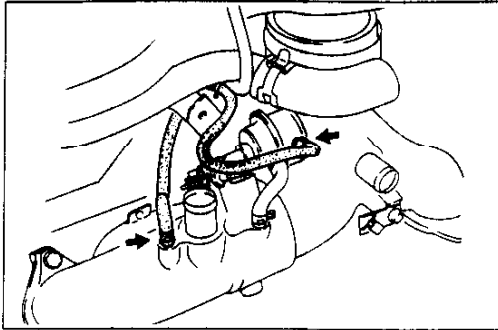

37U0CX-061

Disassembly Note
Air pipe and control valve

1. Disconnect the hoses shown in the figure.

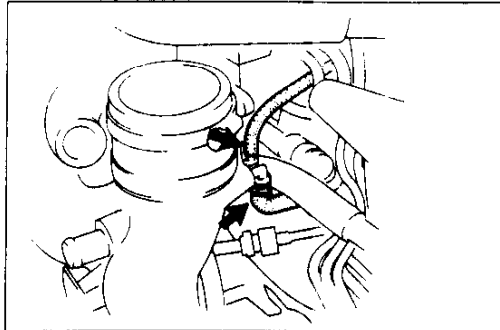

37U0CX-062

2. Disconnect the vacuum hoses shown in the figure.
3. Remove the air pipe and control valve assembly.

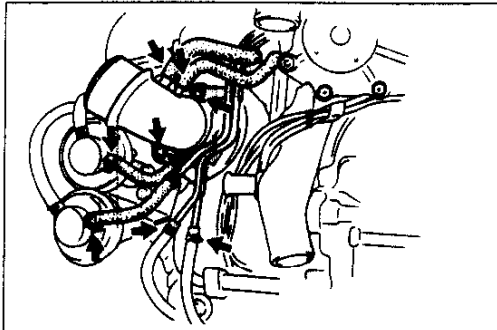

37U0CX-063

Vacuum pipe

1. Disconnect the vacuum hoses shown in the figure.
2. Remove the nuts shown in the figure.
3. Disconnect the vacuum pipe from the turbocharger.

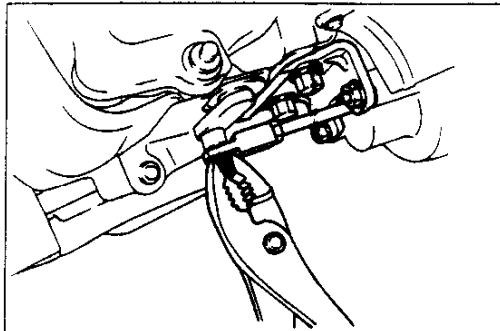

37U0CX-064

Turbo control actuator

1. Remove the clip shown in the figure.

Caution

● **Do not reuse the clip.**

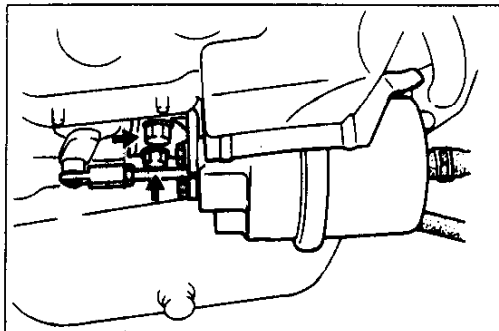

37U0CX-065

2. Remove the bolts and remove the turbo control actuator.

C

DISASSEMBLY

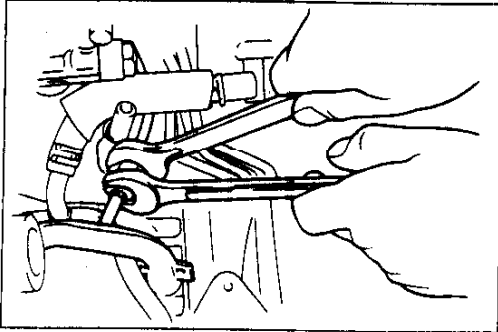

37U0CX-066

Turbocharger assembly

Caution

- Hold the pipe by using a wrench.

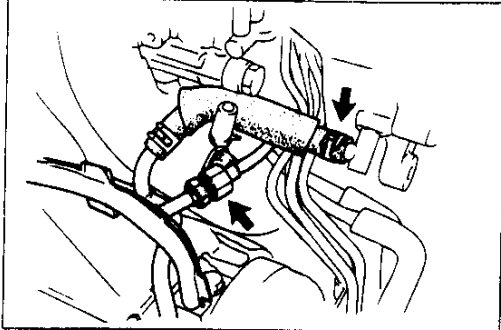

37U0CX-067

1. Disconnect the water hose and the oil inlet pipe shown in the figure.

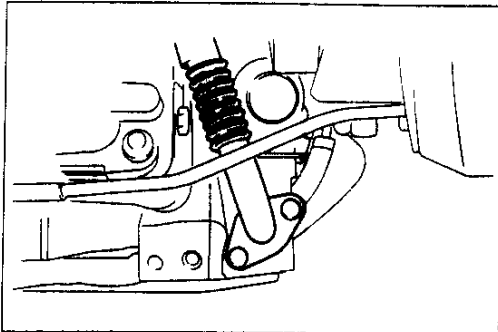

37U0CX-068

2. Disconnect the oil outlet pipes.

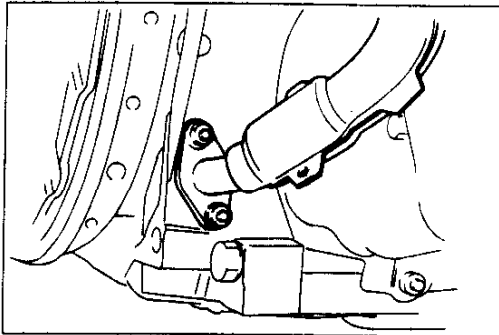

37U0CX-069

3. Disconnect the water hose.

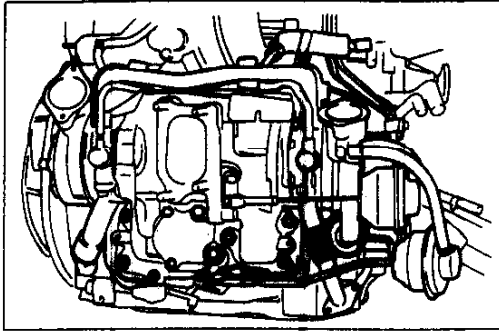

37U0CX-070

4. Remove the bolts and nuts and remove the turbocharger assembly.

Caution

- Do not reuse the nuts.

AUXILIARY PARTS (II)

Disassemble in the order shown in the figure, referring to **Disassembly Note**.

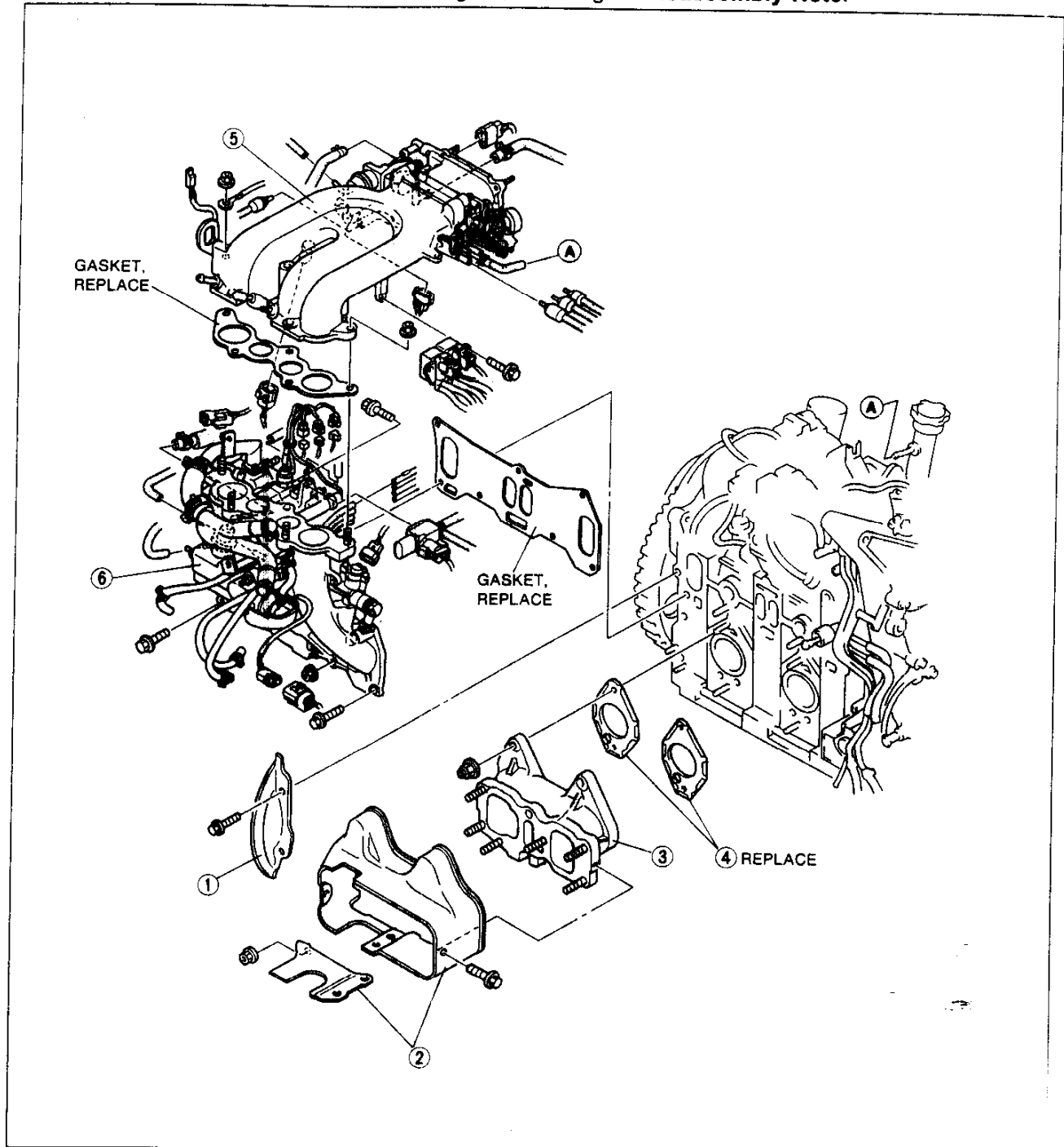

37U0CX-071

- 1. Oil seal plate
- 2. Exhaust manifold insulator
- 3. Exhaust manifold
- 4. Exhaust manifold gasket

- 5. Surge tank assembly
Disassembly Note page C-31
- 6. Intake manifold assembly
Disassembly Note page C-32

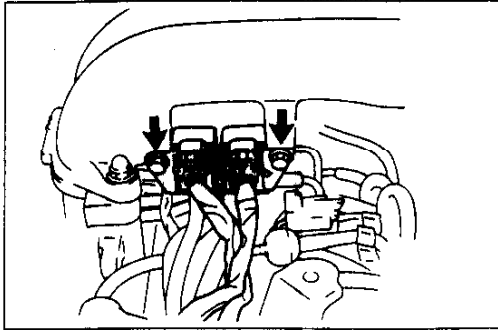

37U0CX-072

Disassembly Note
Surge tank assembly

1. Remove the bolts shown in the figure.
2. Disconnect the duty solenoid valve from the surge tank.

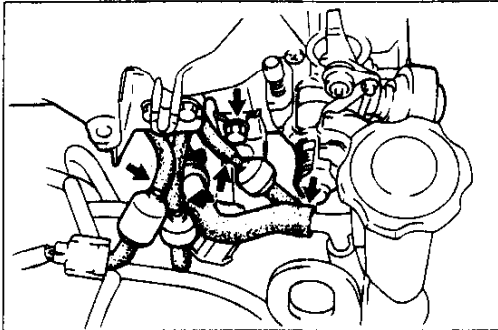

37U0CX-073

3. Disconnect the vacuum hoses and blowby hose shown in the figure.
4. Loosen the bolt shown in the figure.

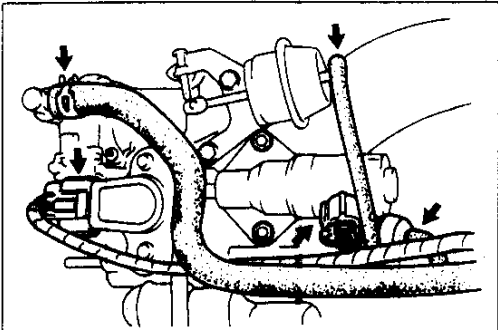

37U0CX-074

5. Disconnect the hoses and connectors shown in the figure.

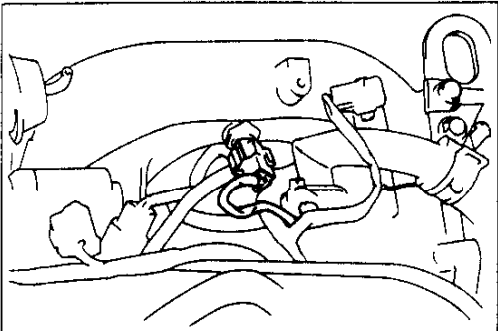

37U0CX-075

6. Disconnect the connector shown in the figure.

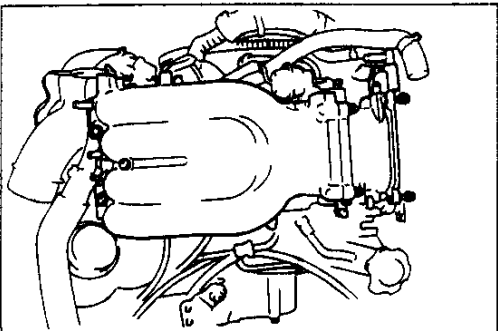

37U0CX-076

7. Remove the bolts and remove the surge tank assembly.

C

DISASSEMBLY

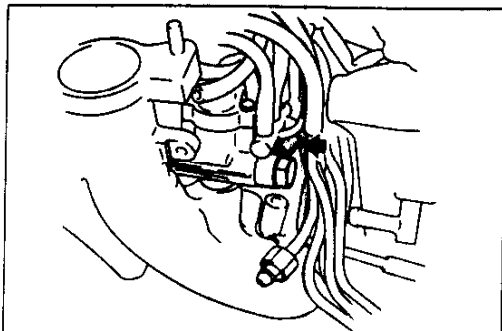

37U0CX-077

Intake manifold assembly

1. Disconnect the hose shown in the figure.

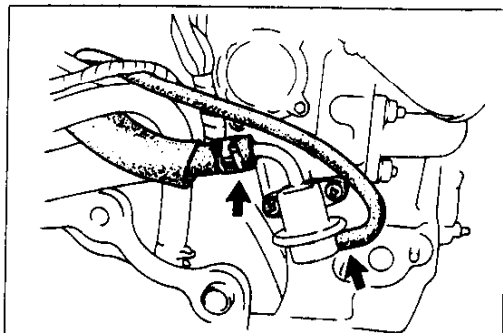

37U0CX-078

2. Disconnect the fuel hose and vacuum hose shown in the figure.

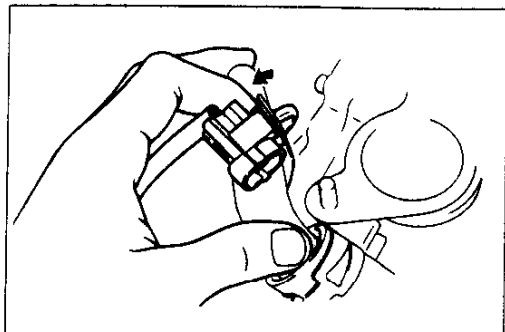

37U0CX-079

3. Remove the oxygen sensor connector.

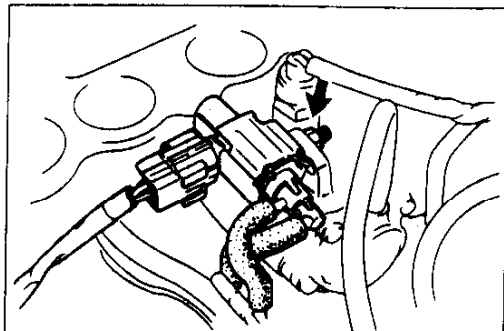

37U0CX-080

4. Remove the nut shown in the figure.
5. Remove the three-way solenoid.

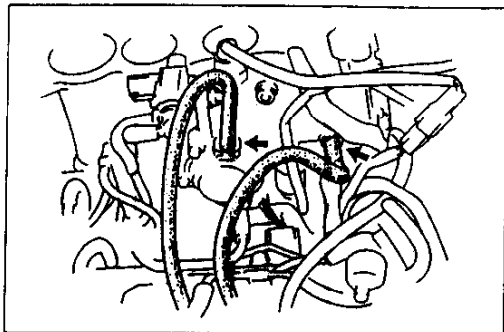

37U0CX-081

6. Disconnect the vacuum hoses shown in the figure.

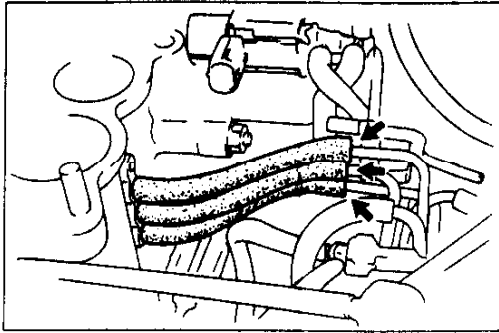

37U0CX-082

7. Disconnect the vacuum hoses shown in the figure.

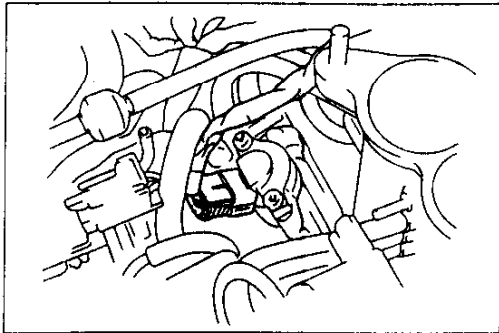

37U0CX-083

8. Disconnect the injector connectors.

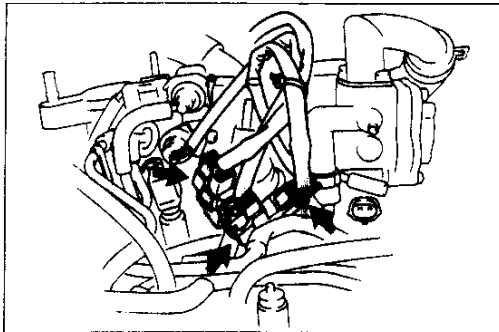

37U0CX-084

9. Disconnect the connectors.

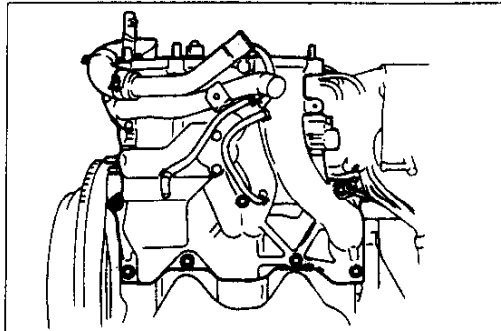

37U0CX-085

10. Remove the intake manifold assembly.

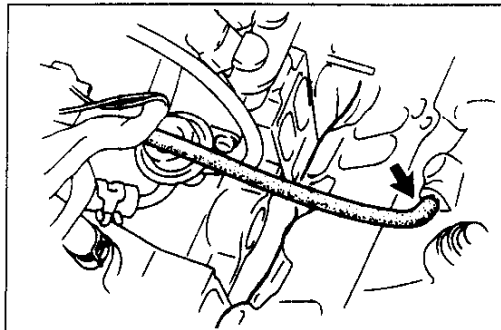

37U0CX-086

11. Disconnect the vacuum hose.

C

DISASSEMBLY

Vacuum pipe assembly

Disconnect the hoses and connectors shown in the figure.

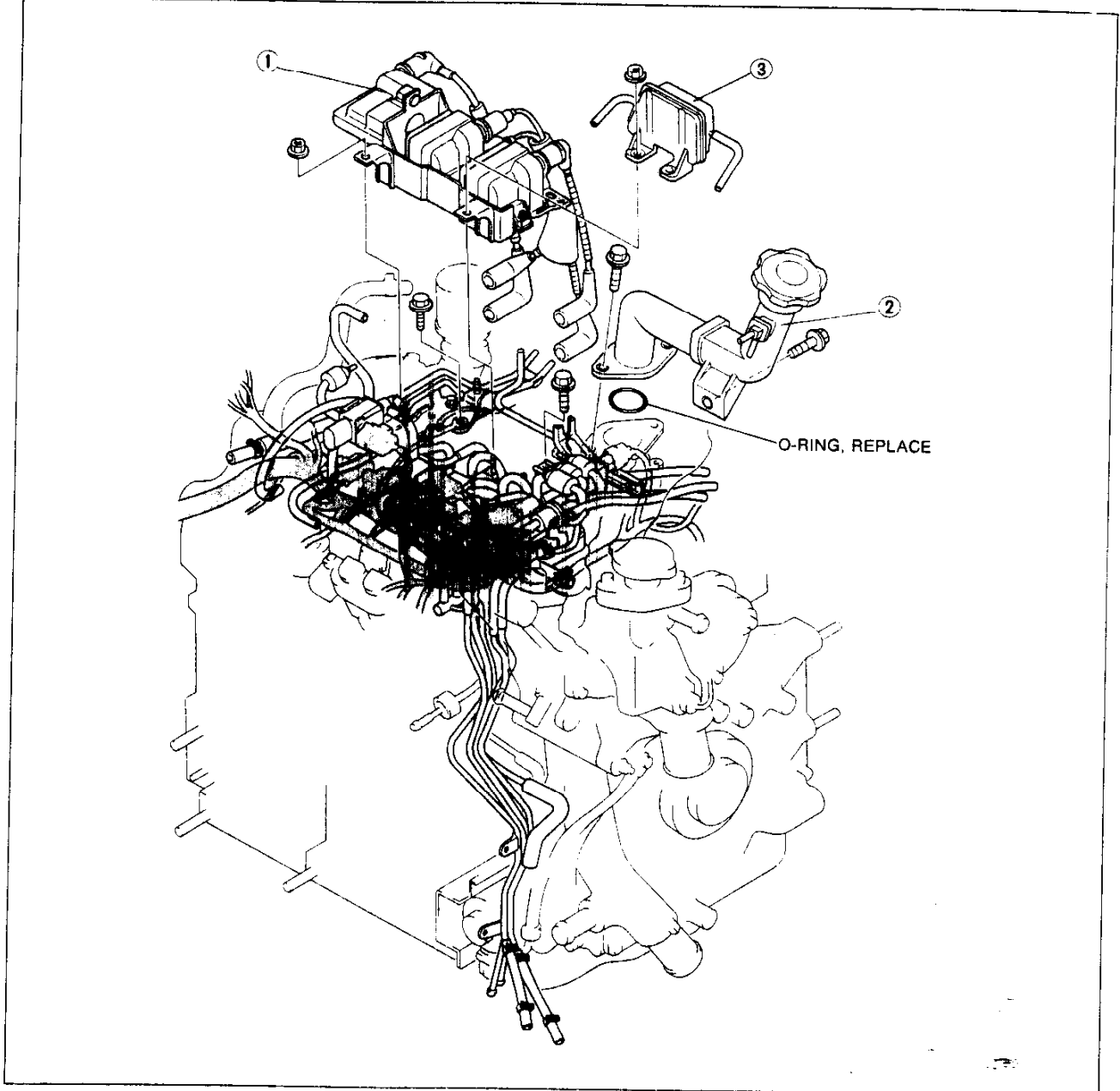

1. Ignition coil assembly

Disassembly Note below

2. Oil filler pipe

3. Vacuum chamber

37U0CX-08

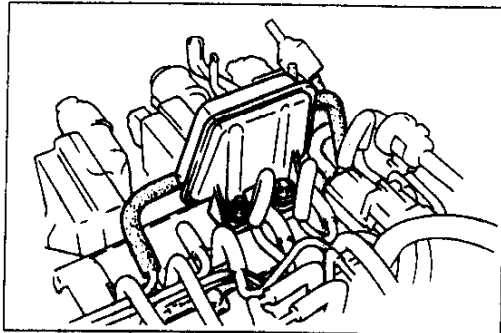

Disassembly Note Ignition coil assembly

1. Remove the vacuum chamber.
2. Remove the ignition coil assembly.

37U0CX-088

Harness

Disconnect the harness connectors shown in the figure.

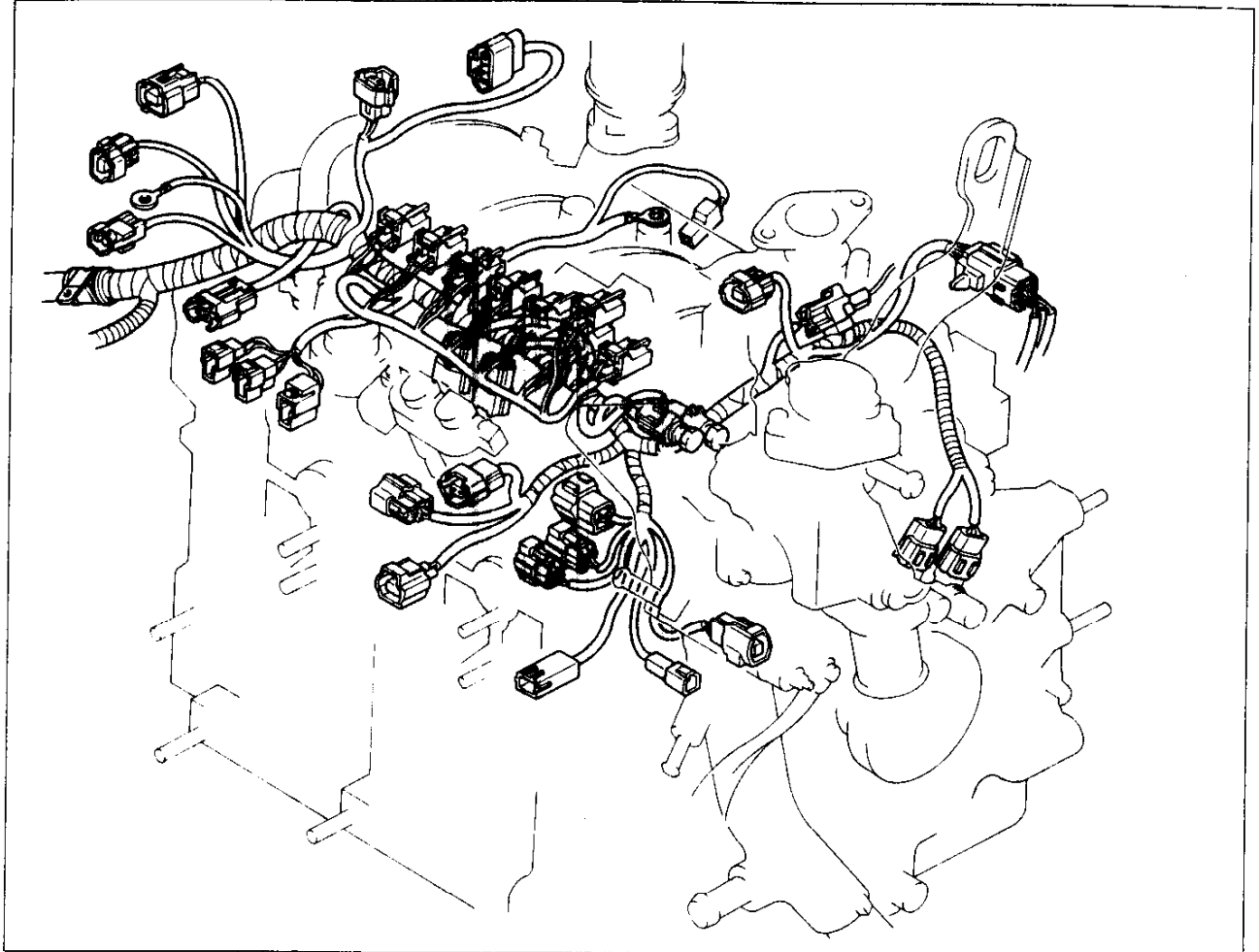

37UOCX-039

C

DISASSEMBLY

HOUSING (EXTERNAL PARTS I)

Disassemble in the order shown in the figure, referring to **Disassembly Note**.

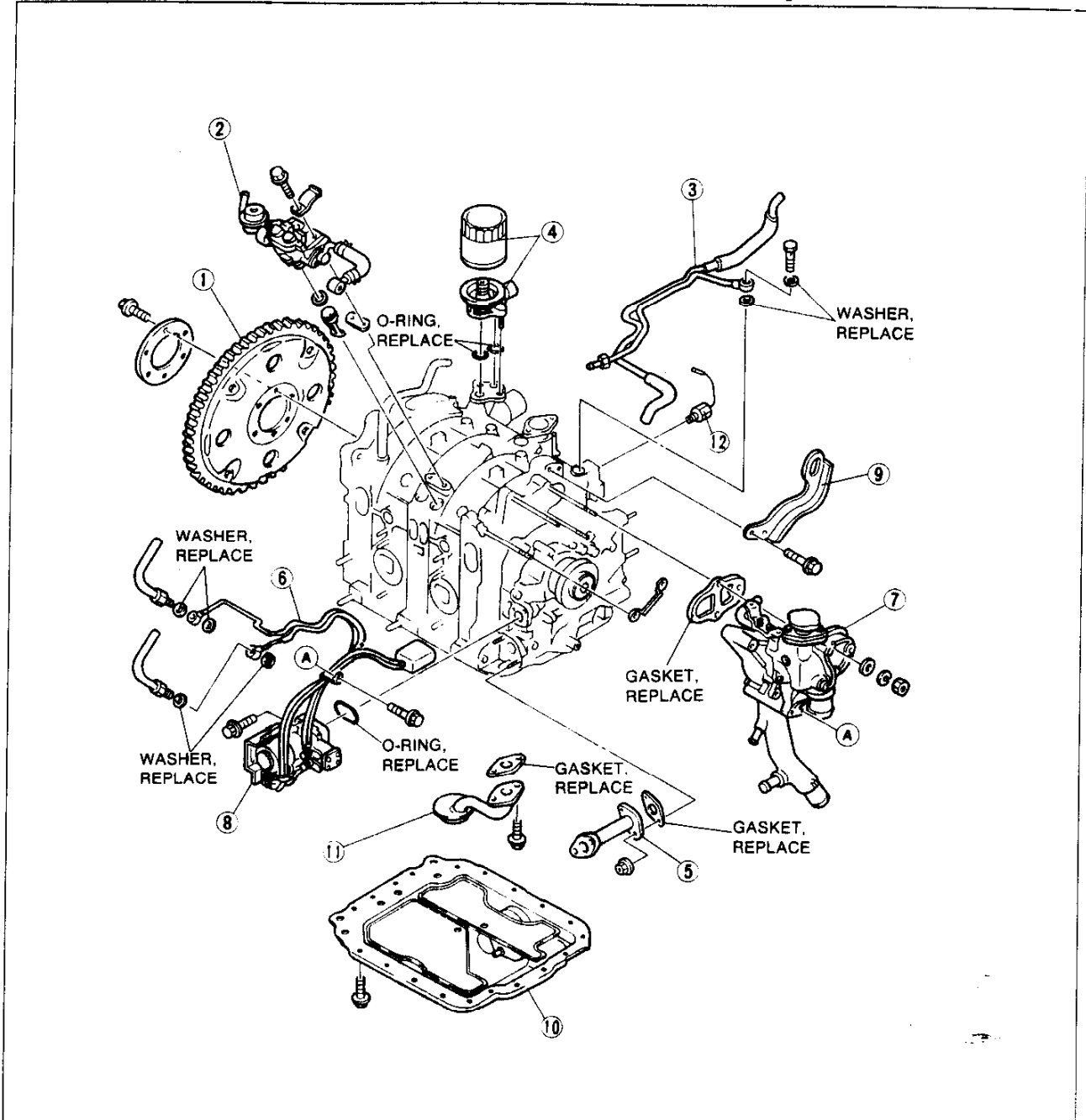

37U0CX-09C

1. Drive plate (AT)
Disassembly Note page C-37
2. Fuel delivery pipe and mixing plate
Disassembly Note page C-37
Service Section F
3. Oil inlet pipe
4. Oil filter body
5. Oil pipe
6. Metering oil nozzle
Service Section D

7. Water pump body
Disassembly Note page C-37
Service Section E
8. Metering oil pump
Service Section D
9. Engine hanger
10. Oil pan
Disassembly Note page C-38
11. Oil strainer
12. Knock sensor
Disassembly Note page C-38

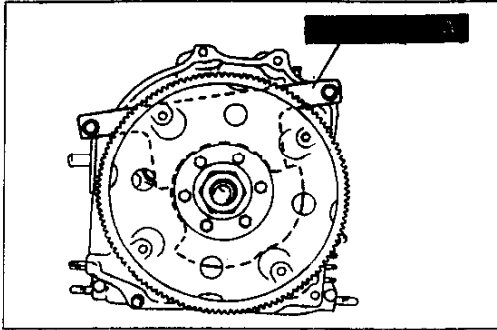

37U0CX-091

**Disassembly Note
Drive plate (AT)**

1. Attach the **SST** to the counterweight.

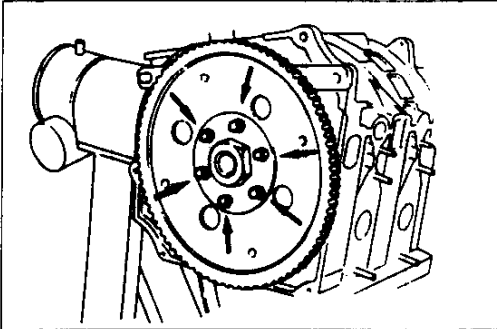

37U0CX-092

2. Remove the retainer and the drive plate.

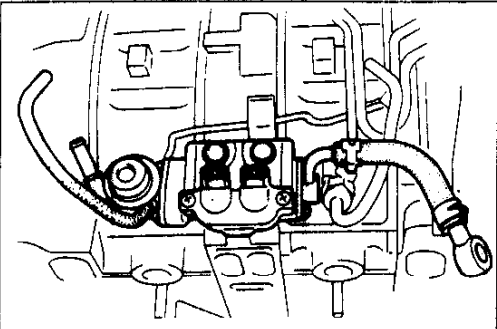

37U0CX-093

Fuel delivery pipe and mixing plate

1. Remove the fuel delivery pipe and spacer.

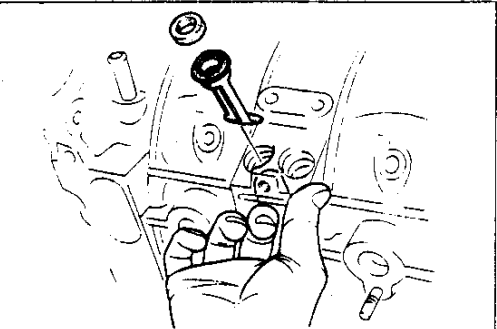

37U0CX-094

2. Reach into the intake port and push out the mixing plate by hand.

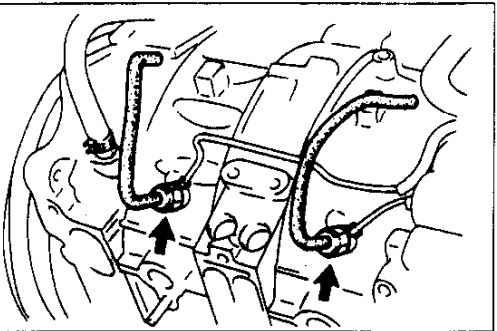

37U0CX-095

Water pump body

1. Disconnect the metering oil tubes.

C

DISASSEMBLY

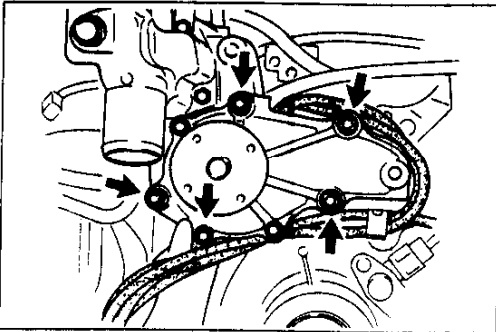

37U0CX-096

2. Remove the water pump body and spacer.

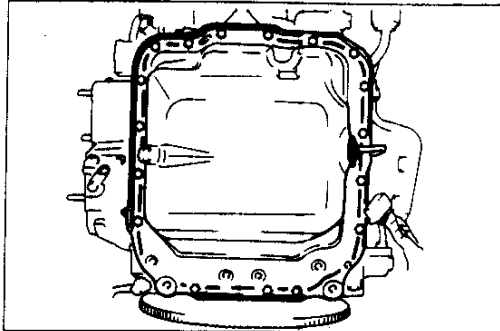

37U0CX-097

Oil pan

1. Remove the oil pan attaching bolts.

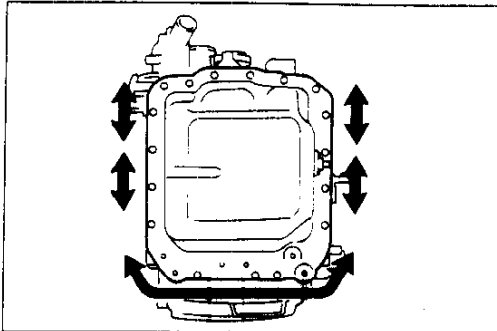

2. Remove the oil pan by inserting screwdriver or a suitable tool into only the areas shown in the figure.

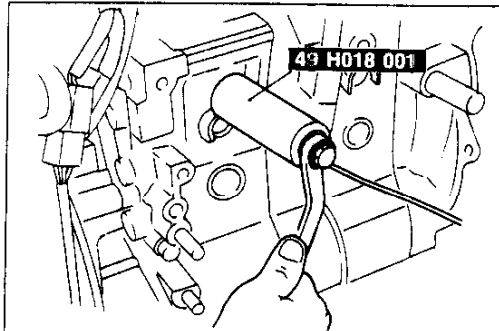

37U0CX-098

Knock sensor

- Remove the knock sensor by using the **SST**.

HOUSING (EXTERNAL PARTS II)

Disassemble in the order shown in the figure, referring to **Disassembly Note**.

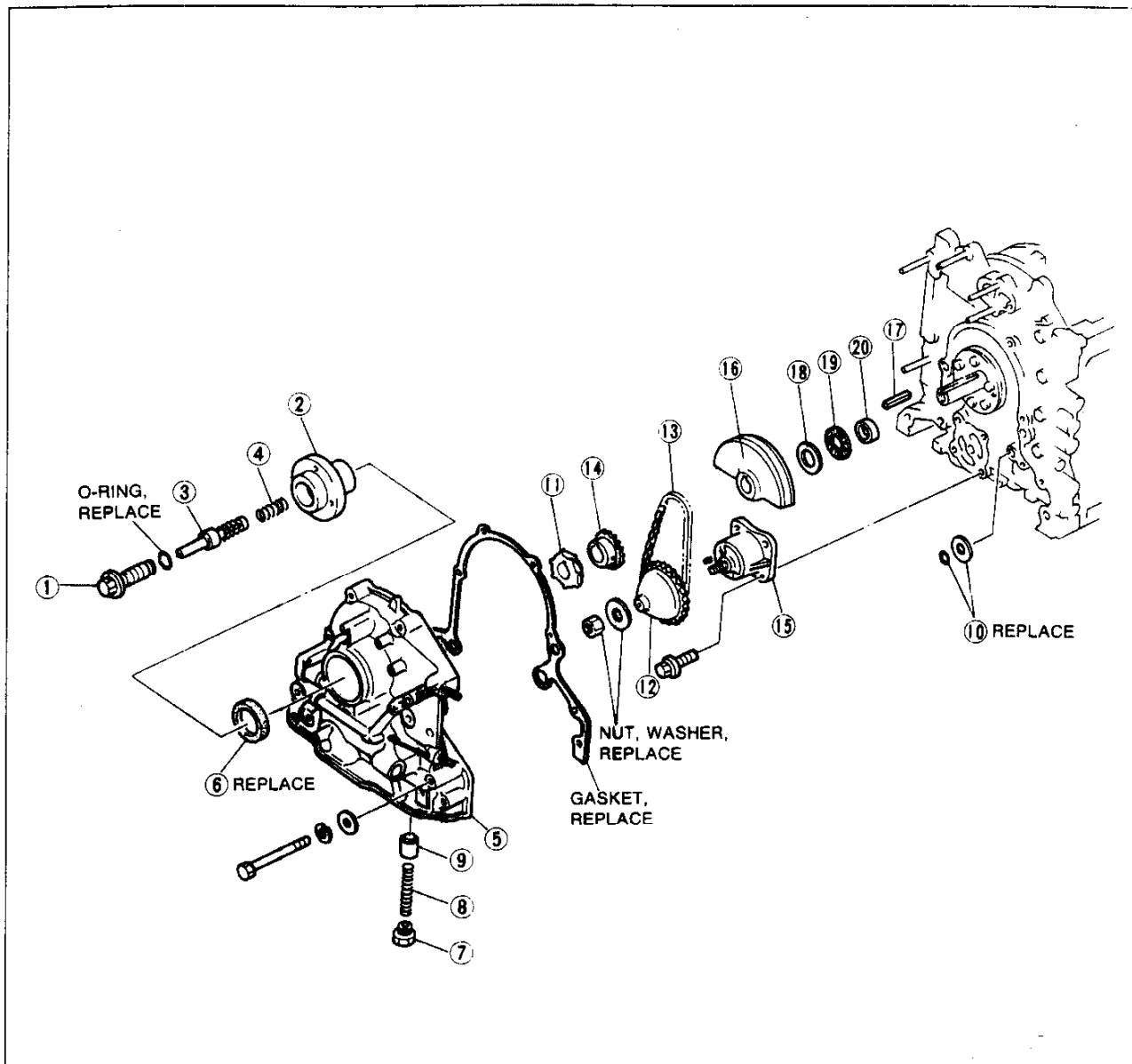

37UOCX-099

- | | |
|--|---|
| 1. Eccentric shaft lock bolt
Disassembly Note page C-40 | 12. Oil pump sprocket wheel
Disassembly Note page C-40 |
| 2. Pully boss | 13. Oil pump drive chain
Inspection page C-59 |
| 3. Eccentric shaft bypass valve
Inspection page C-59 | 14. Oil pump drive gear
Inspection page C-59 |
| 4. Spring | 15. Oil pump
Service Section D |
| 5. Front cover | 16. Balance weight |
| 6. Oil seal
Disassembly Note page C-40 | 17. Key |
| 7. Plug | 18. Thrust washer
Inspection page C-59 |
| 8. Control valve spring | 19. Needle bearing
Inspection page C-59 |
| 9. Control valve | 20. Spacer |

C

DISASSEMBLY

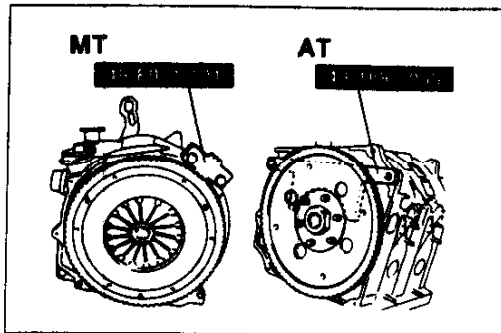

37U0CX-100

Disassembly Note Eccentric shaft lock bolt

1. Attach the **SST** to the flywheel (MT) or counterweight (AT).

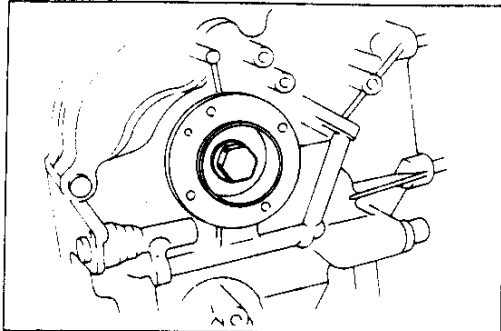

37U0CX-101

2. Remove the eccentric shaft lock bolt.

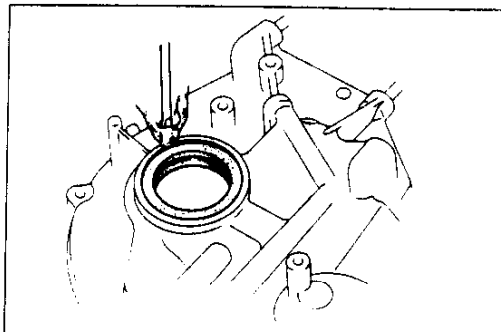

37U0CX-102

Oil seal

Remove the oil seal by using a screwdriver protected with a rag.

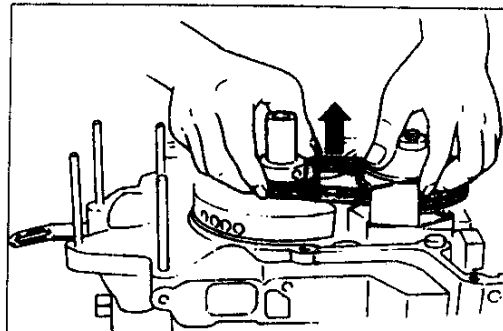

37U0CX-103

Oil pump sprocket wheel

1. Lift the lock washer tab and remove the sprocket locknut.
2. Remove the oil pump drive gear, sprocket wheel, and drive chain as an assembly.

HOUSING (INTERNAL PARTS)

Disassemble in the order shown in the figure, referring to **Disassembly Note**.

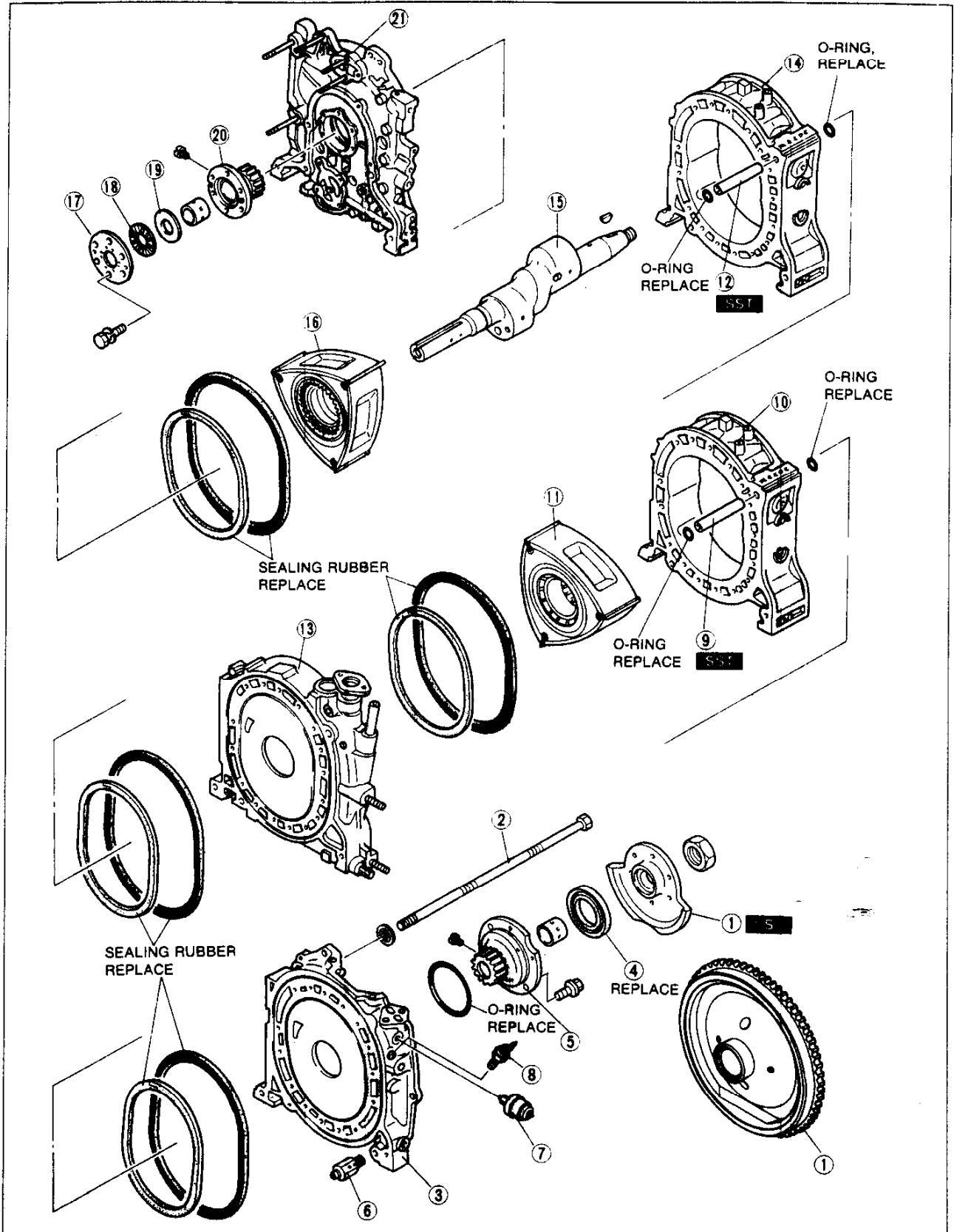

C**DISASSEMBLY**

- | | |
|--|--|
| 1. Flywheel (MT) / Counterweight (AT)
Disassembly Note page C-44 | 12. Tubular dowel
Disassembly Note page C-47 |
| 2. Tension bolts
Disassembly Note page C-45 | 13. Intermediate housing
Disassembly Note page C-47
Inspection page C-51 |
| 3. Rear housing
Disassembly Note page C-45
Inspection page C-51 | 14. Front rotor housing
Disassembly Note page C-47
Inspection page C-54 |
| 4. Rear oil seal
Disassembly Note page C-45 | 15. Eccentric shaft
Inspection page C-58 |
| 5. Rear stationary gear
Inspection page C-52 | 16. Front rotor
Disassembly Note page C-47
Inspection page C-54 |
| 6. Oil regulator valve
Service Section D | 17. Plate |
| 7. Oil pressure switch
Disassembly Note page C-45 | 18. Needle bearing
Inspection page C-59 |
| 8. Heat gauge unit | 19. Thrust washer
Inspection page C-59 |
| 9. Tubular dowel
Disassembly Note page C-46 | 20. Front stationary gear
Inspection page C-52 |
| 10. Rear rotor housing
Disassembly Note page C-46
Inspection page C-54 | 21. Front housing
Inspection page C-51 |
| 11. Rear rotor
Disassembly Note page C-46
Inspection page C-54 | |

HOUSING (ROTOR)

Disassemble in the order shown in the figure, referring to **Disassembly Note**.

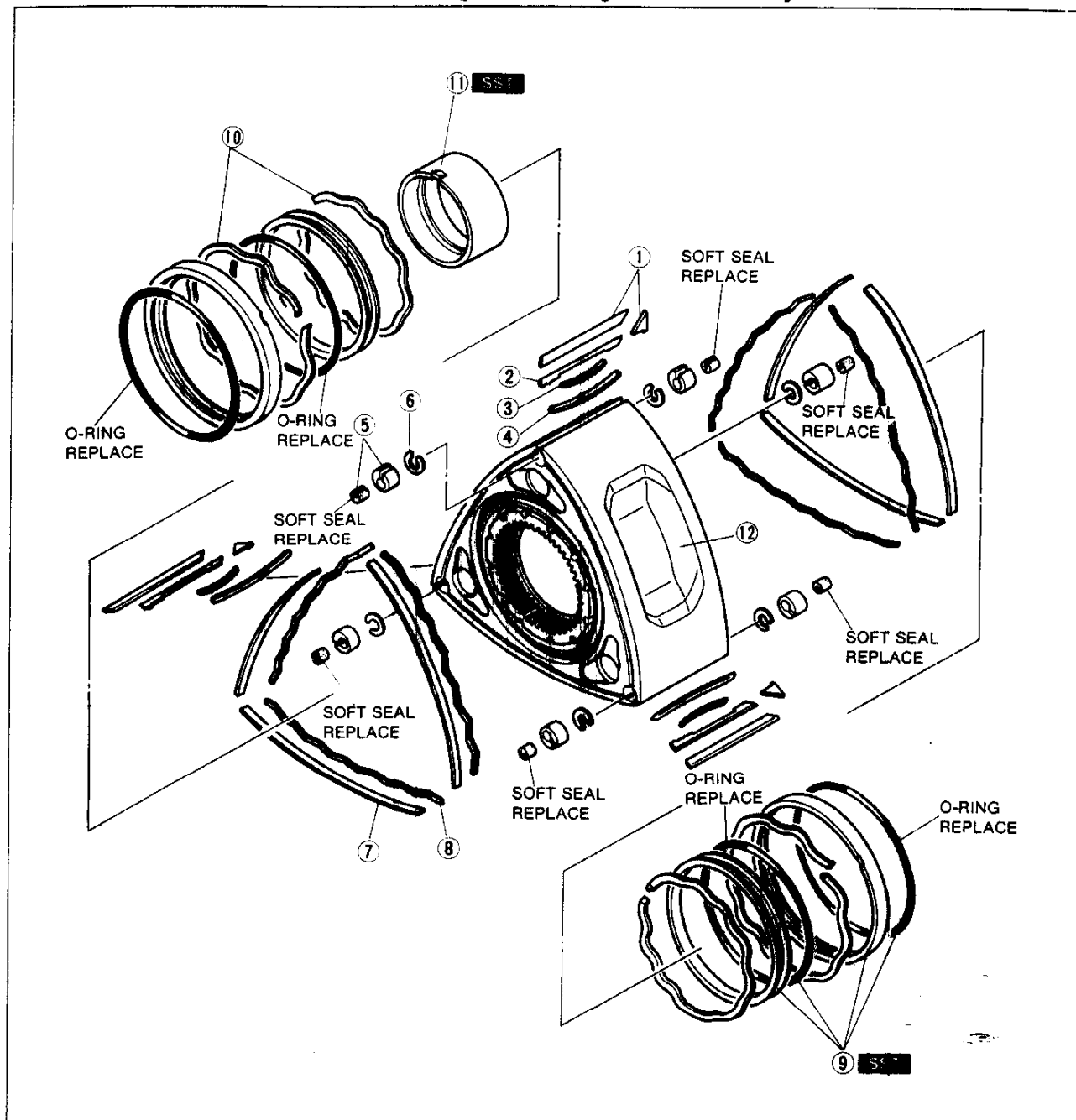

37U0CX-105

- 1. Apex seal and side piece
Inspection page C-57
- 2. Second piece
Inspection page C-57
- 3. Apex seal spring (short)
- 4. Apex seal spring (long)
- 5. Corner seal
Inspection page C-58
- 6. Corner seal spring

- 7. Side seal
Inspection page C-57
- 8. Side seal spring
- 9. Oil seal and O-ring
Disassembly Note page C-48
Inspection page C-56
- 10. Oil seal spring
- 11. Rotor bearing
Inspection page C-56
- 12. Rotor
Inspection page C-55

C

DISASSEMBLY

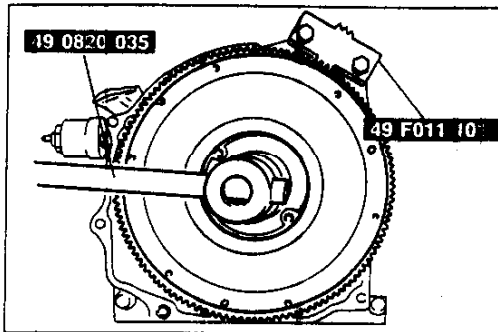

97U0CX-106

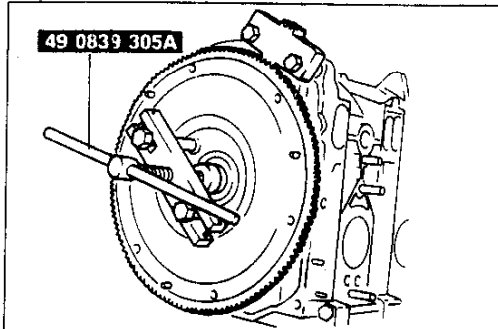

37U0CX-107

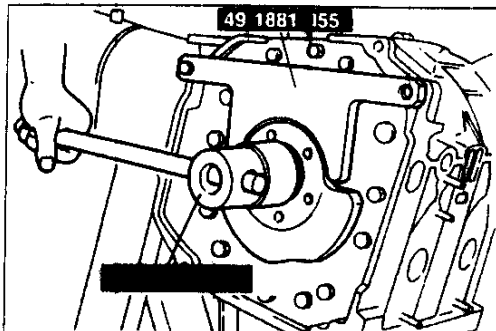

37U0CX-108

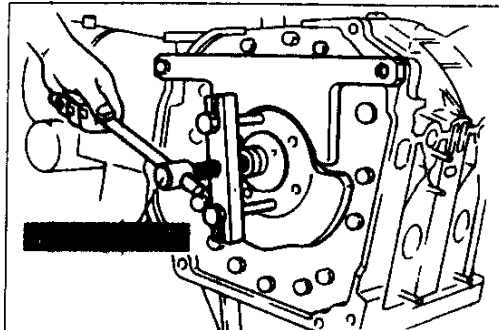

37U0CX-109

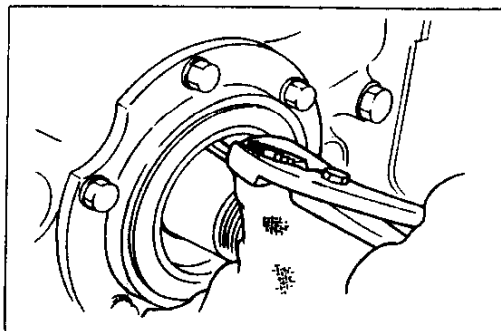

37U0CX-110

Disassembly Note Flywheel (MT)

1. Remove the flywheel nut by using the **SST**.

2. Remove the flywheel by using the **SST**.

3. Remove the key.

4. Remove the **SST**.

Counterweight (AT)

1. Remove the counterweight nut by using the **SST**.

2. Remove the counterweight by using the **SST**.

3. Remove the key by using a rag.

4. Remove the **SST**.

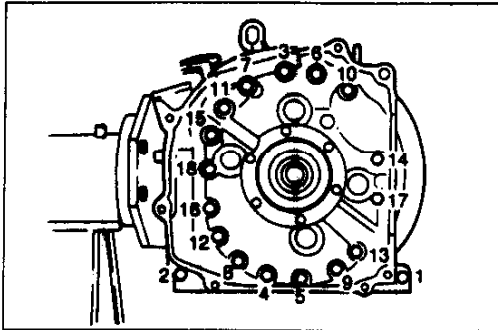

37U0CX-111

Tension bolts

Loosen the tension bolts gradually and in the sequence shown in the figure; then remove them.

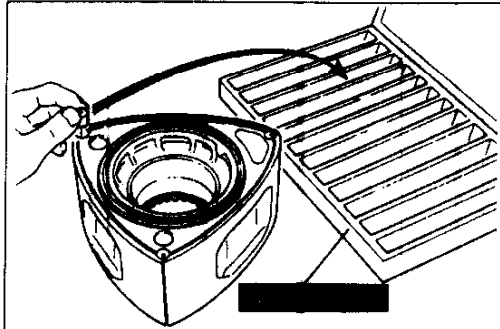

37U0CX-112

Note

- Rotor seals – apex seals, side seals and corner seals – are distinguishable by the numbers near each respective groove on the rotor face. Place them in the SST in accordance with the numbers.

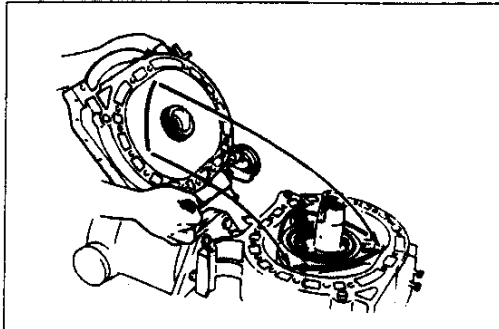

37U0CX-113

Rear housing

1. Remove the rear housing.
2. If the seals stick to the housing when it is removed, put them back into their original position.

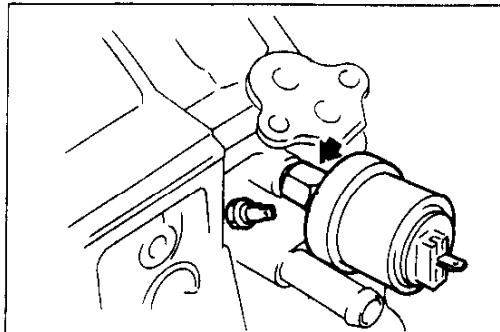

37U0CX-114

Oil pressure switch

Remove the oil pressure switch by using a wrench.

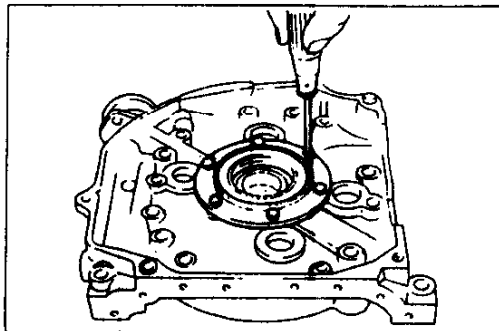

37U0CX-115

Rear oil seal

Remove the oil seal cover and the oil seal from the rear housing.

C

DISASSEMBLY

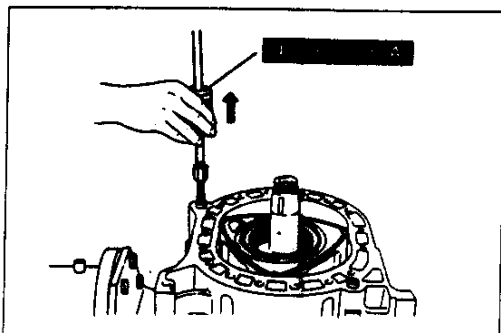

37U0CX-116

Tubular dowel

Remove the tubular dowels by using the **SST**.

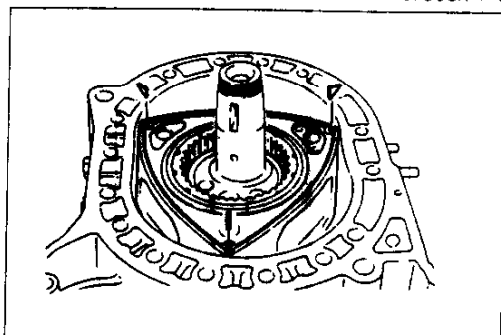

37U01X-117

Rear rotor housing

1. Remove the side pieces and place them in the **SST**.

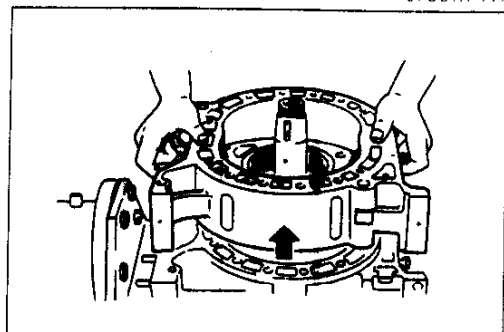

37U0CX-118

2. Remove the rotor housing. Be careful not to drop the apex seals.
3. Remove the O-ring from the upper dowel hole.

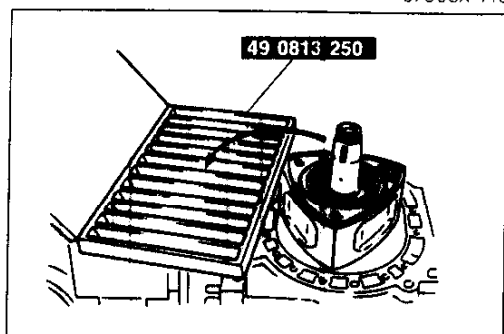

37U0CX-119

Rear rotor

1. Remove the seals and springs, and place them in position in **SST**.

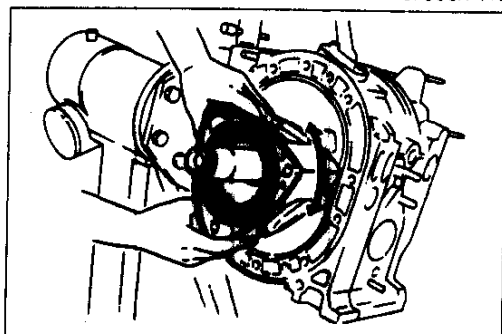

37U0CX-120

2. Remove the rotor.
If the seals stick on the intermediate housing surface put them back into their respective position in the rotor.

Caution

- Do not place the rotor on a hard surface.

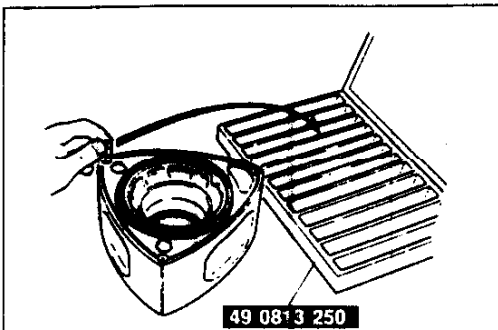

37U0CX-121

3. Remove the seals and springs, and put them in position in the **SST**.
4. Mark the rotor with an "R" for proper reassembly.

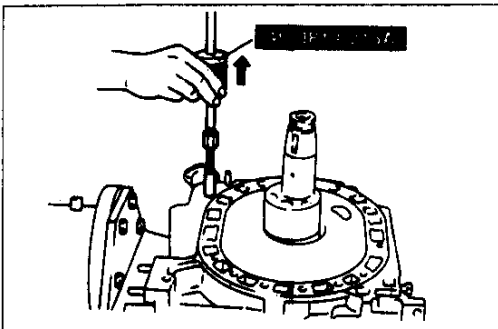

37U0CX-122

Tubular dowel

Remove the tubular dowels by using the **SST**.

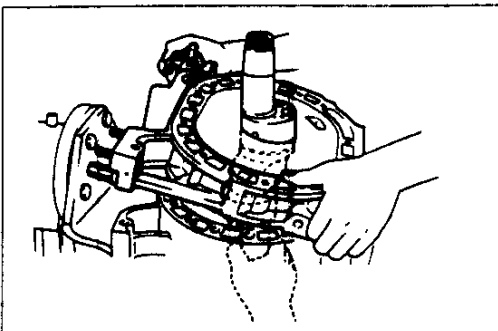

37U0CX-123

Intermediate housing

1. Turn the eccentric shaft so that the rotor journal faces in the short axial direction.
2. Remove the intermediate housing while pushing the eccentric shaft up.
3. If the seals stick to the intermediate housing surface, put them back into their respective position in the rotor.
4. Remove the sealing rubbers.

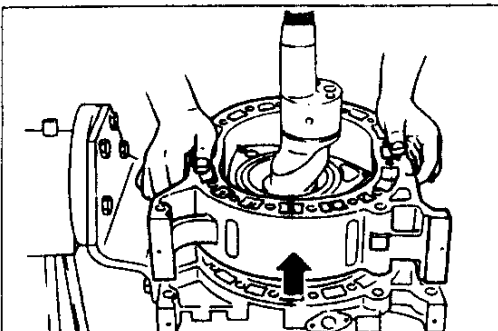

37U0CX-124

Front rotor housing

1. Remove the side pieces and place them in the **SST**.
2. Remove the rotor housing. Be careful not to drop the apex seals.
3. Remove the O-ring from the upper dowel hole.

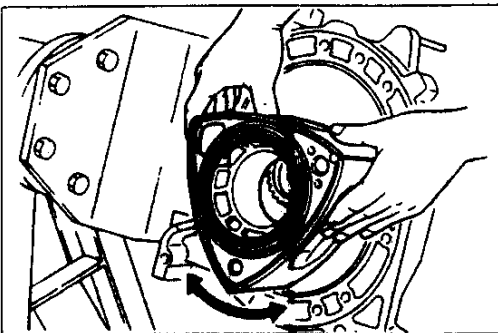

37U0CX-125

Front rotor

Remove the front rotor in the same procedure as the removal of the rear rotor.

C

DISASSEMBLY

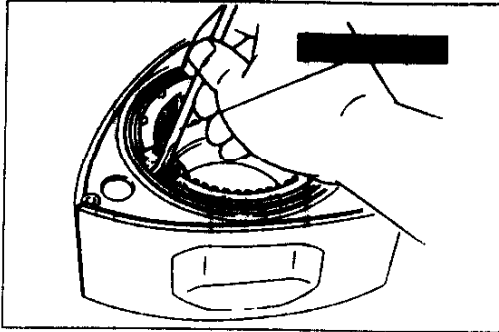

97U0CX-080

Rotor oil seal

1. Remove the outer oil seal from the rotor by using the **SST**.
2. Remove the inner oil seal in the same manner.
3. Remove the oil seal springs.
4. Remove the O-ring from the oil seal.

CLEANING

**PREPARATION
SST**

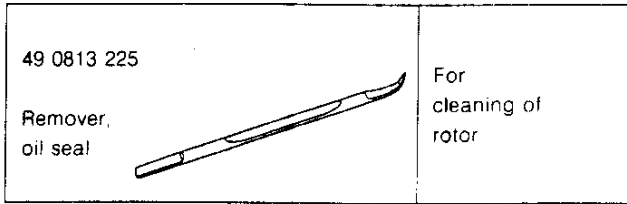

37U0CX-126

Clean all parts, taking care to remove any gasket fragments, dirt, oil, grease, carbon, and other materials.

97U0CX 082

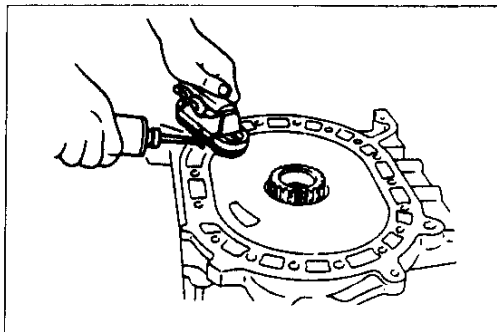

97U0CX-083

Side Housings (front, intermediate and rear housings)

1. Remove the sealing agent from the housing surface by using a cloth or a brush soaked in solvent or thinner.

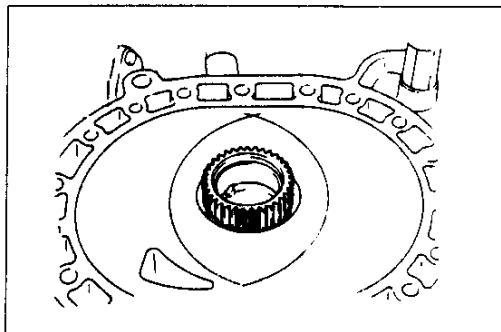

67U01X-078

2. Remove all carbon from the rotor chamber surface by using extrafine emery paper.

Caution

- If using a carbon scraper, be careful not to damage the surface.

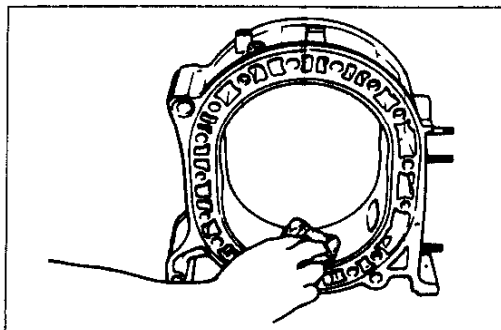

67U01X-079

Rotor Housing

Note

- Before cleaning, check for traces of gas or water leakage along the inner margin of the rotor housings.

1. Remove all carbon from the inner surface of the rotor housing by wiping with a cloth soaked in solvent or thinner.

C

CLEANING

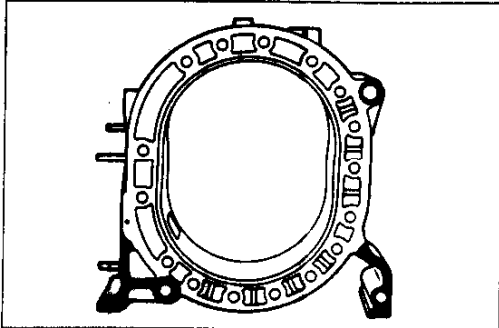

67U01X-080

2. Remove all deposits and rust from the coolant passages of the housing.
3. Remove the sealing agent from the housing by wiping with a cloth or brush soaked in solvent or thinner.

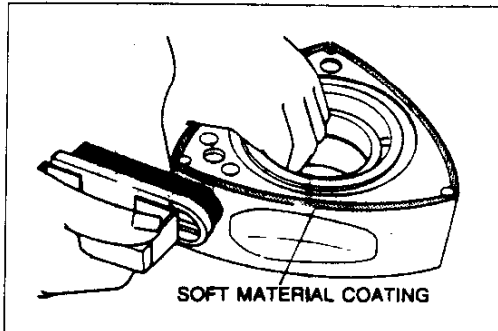

SOFT MATERIAL COATING

37U0CX-127

Rotor

1. Remove the carbon from the rotor by using a nonabrasive sponge and carbon cleaner.

Caution

- Take care not to damage the soft material coating on the side surfaces.

2. Remove the carbon from each groove.
3. Wash the rotor with a cleaning solution.

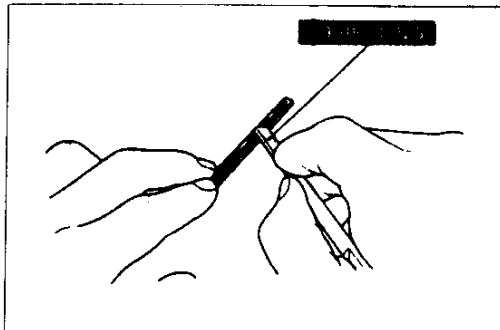

97U0CX-084

Rotor Seals (apex, side and corner seals)

1. Remove the carbon from each seal by using the SST.
2. Wash the seals with a cleaning solution.

Caution

- Do not use emery paper.

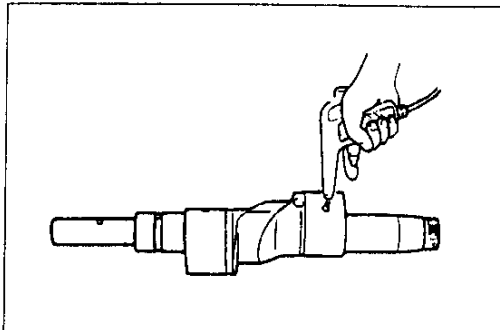



67U01X-084

Eccentric Shaft

1. Wash the eccentric shaft with a cleaning solution.
2. Blow the oil passages clean with compressed air.

INSPECTION / REPAIR

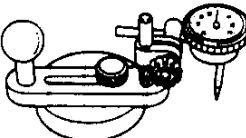
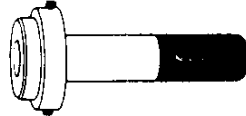
PREPARATION
SST

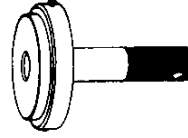
<p>49 0727 570</p> <p>Body gauge</p> 	<p>For inspection of side housing</p>	<p>49 0813 235</p> <p>Puller and installer, main bearing</p> 	<p>For removal / installation of main bearing</p>
<p>49 0839 165</p> <p>Gauge, corner seal</p> 	<p>For inspection of corner seal</p>	<p>49 0813 240</p> <p>Puller and installer, rotor bearing</p> 	<p>For removal / installation of rotor bearing</p>

37U0CX-1E8

1. Clean all parts, being sure to remove any gasket fragments, dirt, oil, grease, carbon, moisture residue, and other foreign materials. (Refer to page C-50.)
2. Inspection and repairs must be performed in the order specified.

Caution

- Do not damage the joints or friction surfaces of aluminum alloy components.

37U0CX 189

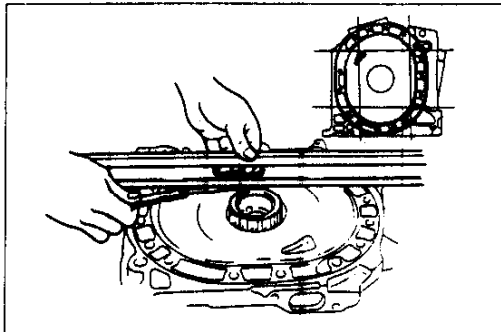

97U0CX 087

Side Housings (front, intermediate and rear housings)

1. Check the housing surface for warpage in the four directions shown in the figure. If necessary, replace the housing.

Warpage: 0.04 mm {0.0016 in} max.

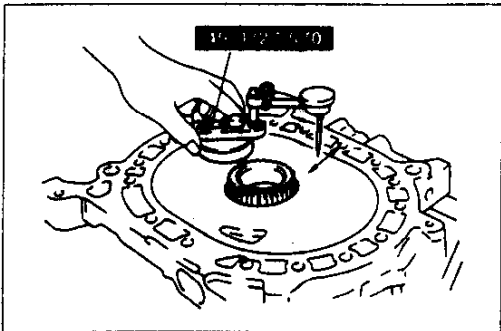

97U0CX-088

2. Check the contact surface for wear by using a dial indicator mounted on the **SST**. Slide the gauge across the area as indicated in the figure.

C

INSPECTION / REPAIR

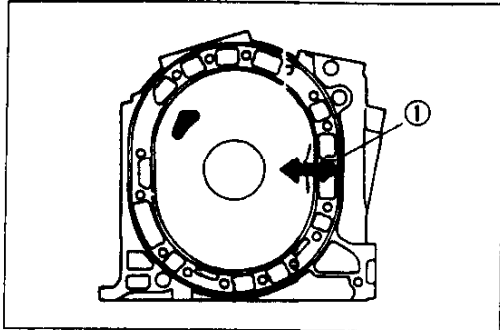

67U01X-087

(1) Side seal wear

Wear: 0.10 mm {0.0039 in} max.

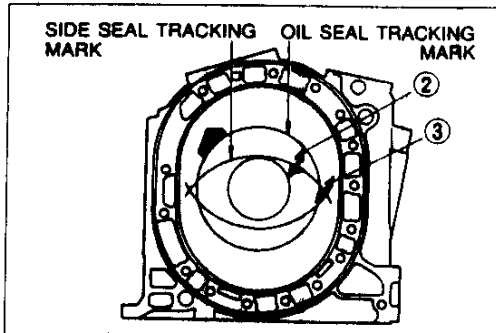

67U01X-088

(2) Side seal wear, overlapping oil seal wear

Wear: 0.01 mm {0.0004 in} max.

(3) Side seal wear, outside oil seal wear

Wear: 0.10 mm {0.0039 in} max.

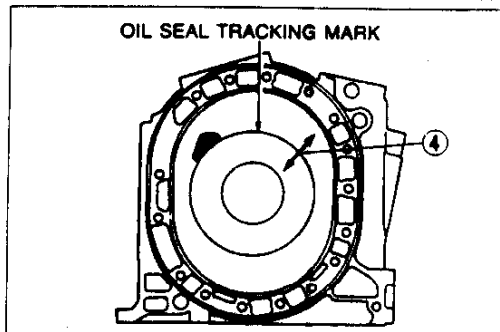

67U01X-089

(4) Oil seal wear

Wear: 0.02 mm {0.0008 in} max.

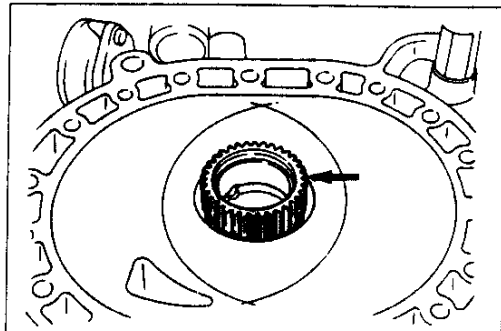

67U01X-090

Stationary Gear

1. Check the front and rear stationary gear for cracked, scored, worn, and chipped teeth.

2. If necessary, replace the stationary gear.

(1) (Front stationary gear)

Remove the plate, needle bearing, and thrust plate.

(Rear stationary gear)

Remove the attaching bolts.

(2) Remove the stationary gear by using the **SST**.

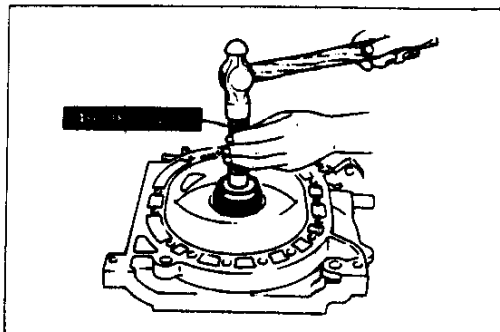

97U0CX-089

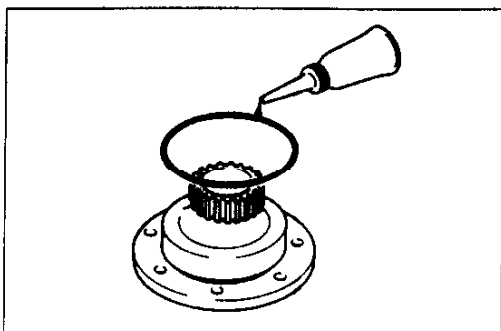

67U01X-092

- (3) (Rear stationary gear only)
Apply petroleum jelly to a new O-ring and install it on the rear stationary gear. Apply sealant to the stationary gear flange.

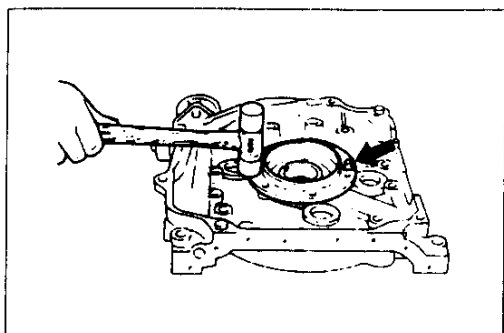

37U0CX-130

- (4) Install the stationary gear to the housing so that the slot of the stationary gear is fit over the dowel on the housing.
- (5) (Front stationary gear)
Install the thrust plate, needle bearing, and plate (Rear stationary gear)
Tighten the attaching bolts.

Tightening torque:

16–22 N·m {1.6–2.3 kgf·m, 12–16 ft·lbf}

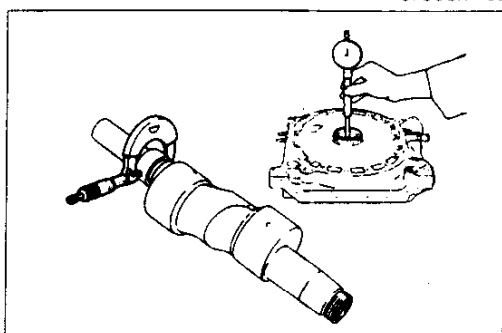
Main Bearing

37U0CX-131

1. Check the main bearing for wear, scoring, flaking, and other damage.
2. Measure the main bearing clearance. Measure the inner diameter of the main bearing and the outer diameter of the eccentric shaft main journal.

Note

- The inside and outside specifications of the journals differ as shown.

Standard clearance:

0.08–0.11 mm {0.0031–0.0043 in} outside

0.06–0.08 mm {0.0023–0.0031 in} inside

Clearance: 0.13 mm {0.0051 in} outside max

0.11 mm {0.0043 in} inside max

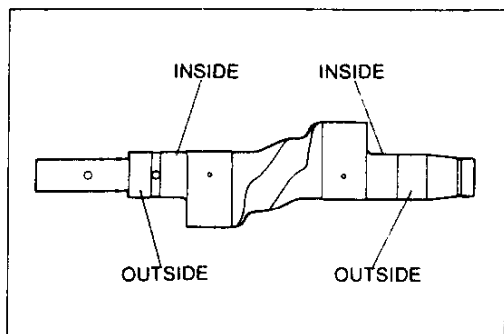

37U0CX-132

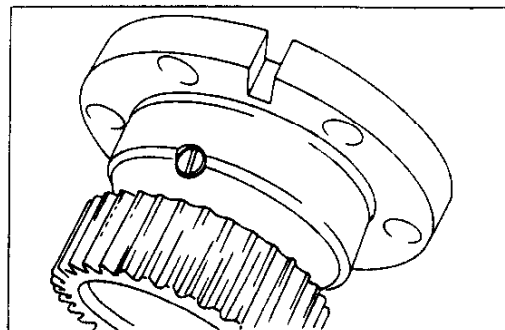

37U0CX-133

3. If necessary replace the main bearing.
 - (1) Remove the stationary gear. (Refer to page C-52.)
 - (2) Remove the screw.

C

INSPECTION / REPAIR

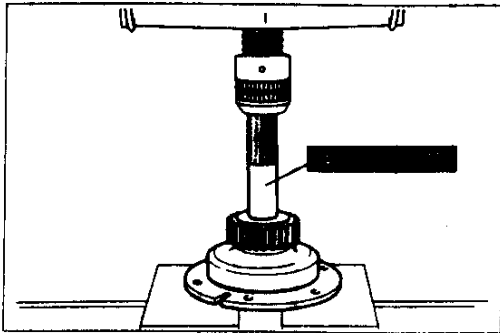

37U0CX-134

- (3) Place the stationary gear on the support with the gear facing upward.
- (4) Press out the main bearing by using the **SST** without the adaptor ring.

Caution

- Do not reuse the main bearing.

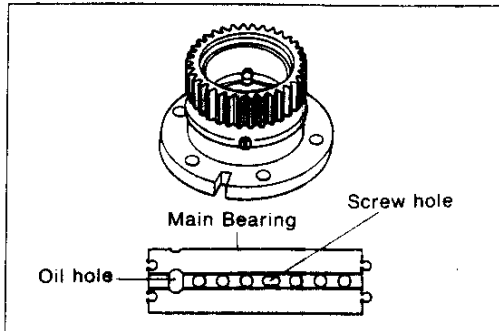

37U0CX-135

- (5) Place the stationary gear on the support with the gear downward.
- (6) Place the new main bearing on the stationary gear so that the small hole is in line with the screw hole of the stationary gear.

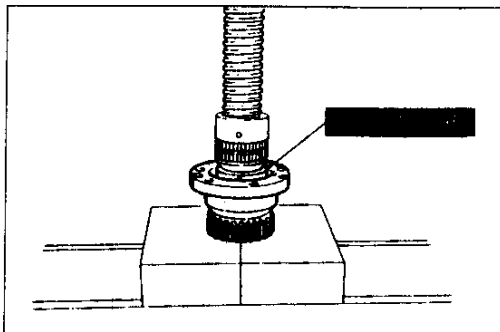

37U0CX-136

- (7) Press in the main bearing by using the **SST**.

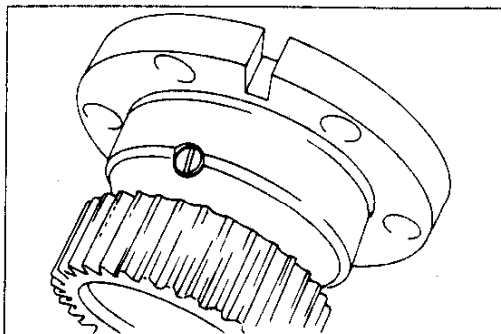

37U0CX-137

- (8) Remove the thread-locking compound from the screw and screw hole threads.
- (9) Apply new thread-locking compound to the screw threads and tighten the screw.

Tightening torque:

3.3–4.7 N·m {33–48 kgf·cm, 29–41 in·lbf}

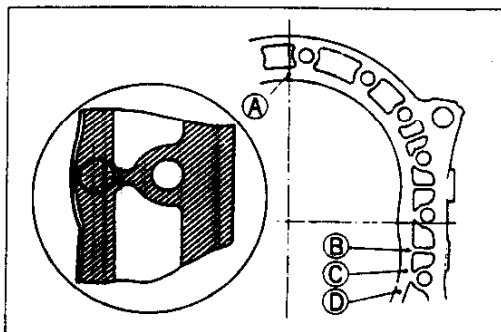

67U01X-097

Rotor Housing

1. Check the chromium plated surface on the rotor housing for scoring, flaking, and other damage.
2. Check the width difference of the rotor housing.
 - (1) Measure the rotor housing width at the points A, B, C, and D, as shown in the figure.

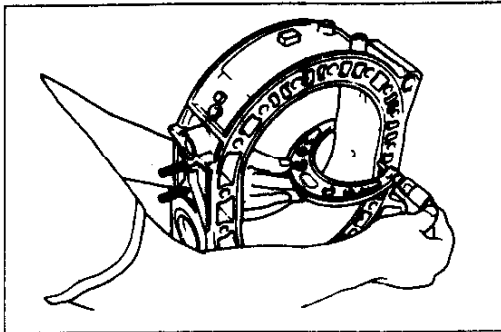

67U01X-098

- (2) Calculate the difference between the value of point A and the minimum value among points B, C, and D.

Difference: 0.06 mm {0.0024 in} max.

3. If the difference exceeds the specification, replace the rotor housing.

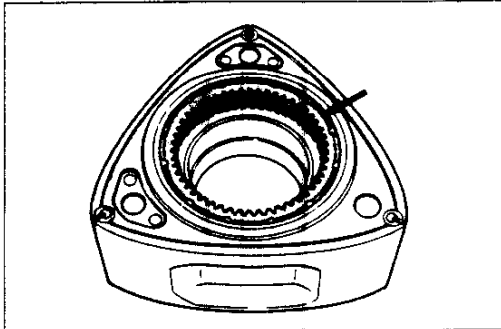

67U01X-099

Rotor

- Carefully inspect the rotor and replace it if it is severely worn or damaged.
- Check the internal gear for cracked, scored, worn, and chipped teeth.

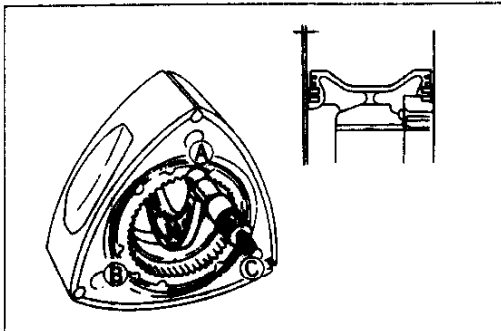

97U0CX-093

3. Check the clearance between the side housing and rotor. Measure the rotor housing width (point A above) and the maximum rotor width at the three points indicated in the figure.

Standard: 0.12–0.21 mm {0.0047–0.0083 in}

Clearance: 0.10 mm {0.0039 in} min.

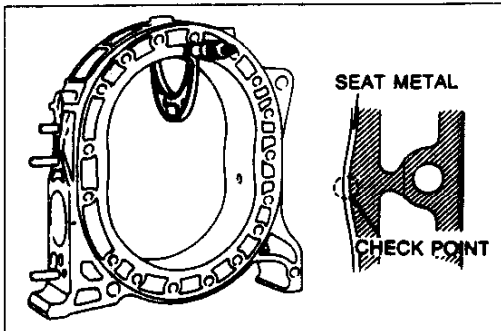

97U0CX-094

4. If the clearance is more or less than specified, replace the rotor assembly.

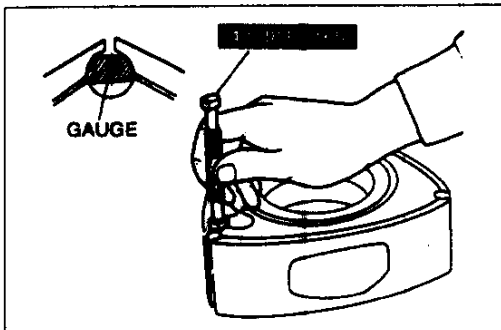

97U0CX-094

5. Check the corner seal bore for wear using the **SST**.

- If neither end of the gauge goes into the bore, use the original corner seal.
- If only one end of the gauge goes into the bore, replace the corner seal.
- If both ends of the gauge go into the bore, replace the rotor.

C

INSPECTION / REPAIR

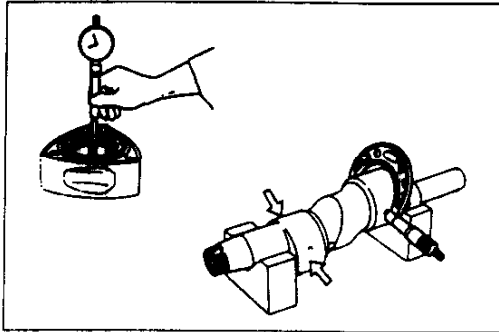

37U0CX-138

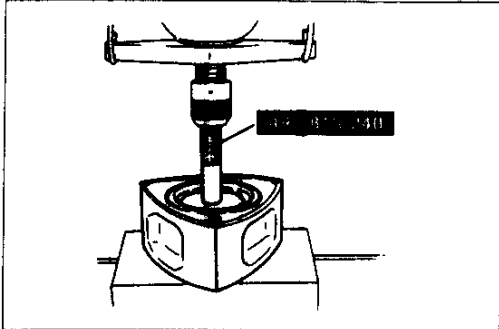

97U0CX-096

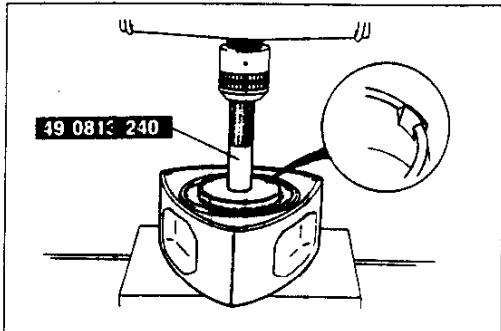

97U0CX-097

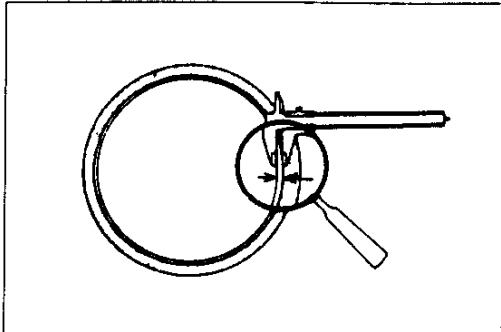

67U01X-106

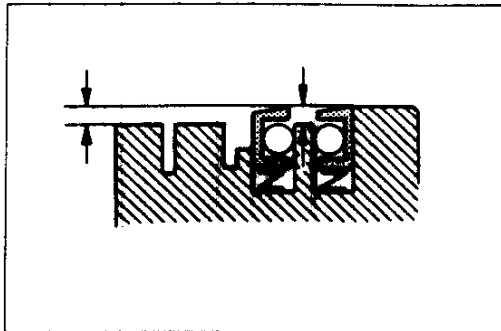

67U01X-107

Rotor Bearing

1. Check the rotor bearing for wear, flaking, scoring, and other damage.
2. Check the rotor bearing clearance. Measure the inner diameter of the rotor bearing and the outer diameter of the eccentric shaft rotor journal.

Standard clearance:

0.06–0.08 mm {0.0016–0.0031 in}

Clearance: 0.11 mm {0.0043 in} max.

3. If not within specification, replace the rotor bearing.
 - (1) Place the rotor on a support with the internal gear downward.
 - (2) Press the bearing out of the rotor by using the **SST** without the adapter ring.

- (3) Place the rotor on the support with the internal gear facing upward.
- (4) Place the new rotor bearing on the rotor so that the bearing lug is in line with the slot of the rotor bore.
- (5) Using the **SST**, press the bearing in until it is flush with the rotor boss.

Rotor Oil Seal

1. Inspect the oil seal for wear and damage. If necessary, replace it.
2. Check the oil seal lip width.

Lip width: 0.5 mm {0.020 in} max.

3. Install the oil seal springs and oil seals into their respective grooves.
4. Check the oil seals for free vertical movement.
5. Check the oil seal protrusion.

Protrusion: 0.5 mm {0.020 in} min.

6. If necessary, replace the oil seal or the spring.

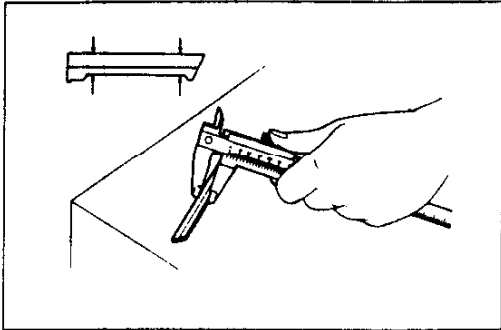

67U01X-108

Apex Seal

1. Check the apex seal for wear, cracks, and other damage. If necessary, replace it.
2. Measure the combined height of the upper and lower apex seals at two points.

Standard height: 8.0 mm {0.315 in}**Height: 6.5 mm {0.256 in} min.****Note**

- Replace the short apex seal spring if the apex seal height is below 7.5 mm {0.295 in}.

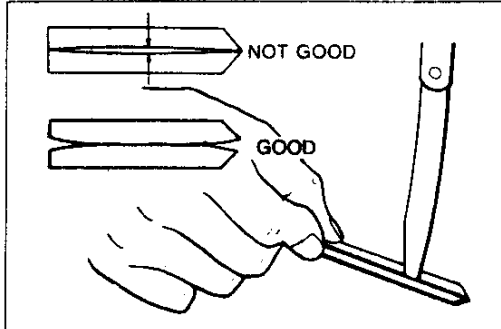

97U0CX-098

3. Check the apex seals for warpage. Put two apex seals together, top-to-top, and check the warpage. Do this with all three seals. If warpage exists in the middle of the seals, replace the apex seals. If the warpage exists in the ends of the seals, the seals can be reused.

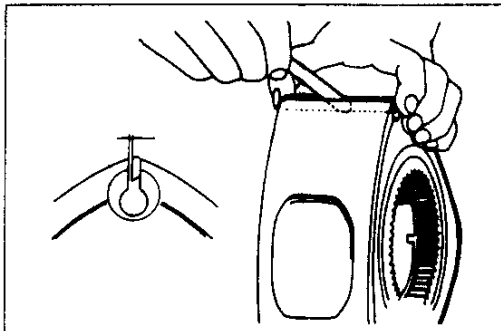

17U0CX-008

4. Check the clearance between the apex seal and the groove. Place the apex seal in its respective groove in the rotor, and measure the apex seal clearance. If necessary, replace it.

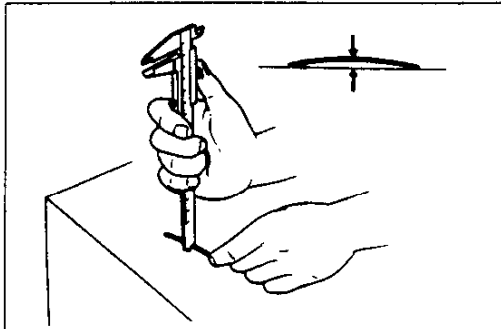
Standard clearance**0.051–0.101 mm {0.0020–0.0040 in}****Clearance: 0.15 mm {0.0059 in} max.**

97U0CX-214

5. Check the apex seal spring for wear and free height. If necessary, replace it.

Free height**Long spring: 4.6 mm {0.181 in} min.****Short spring: 1.7 mm {0.067 in} min.****Note**

- Replace the short apex seal spring if the apex seal height is below 7.5mm {0.295 in}.

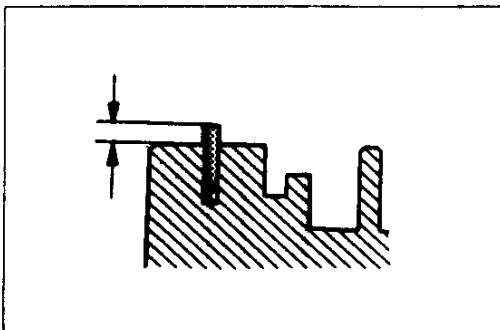

67U01X-114

Side Seal

1. Inspect the side seal for wear and damage. If necessary, replace it.
2. Install the side seal spring and side seal into their respective grooves.
3. Check the side seal for free vertical movement.
4. Check the side seal protrusion.

Protrusion: 0.5 mm {0.020 in} min.

C

INSPECTION / REPAIR

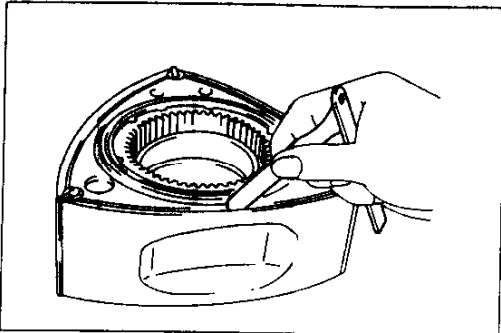

67U01X-115

5. Check the clearance between the side seal and the groove.

Standard clearance:

0.028–0.078 mm {0.0011–0.0031 in}

Clearance: 0.10 mm {0.0039 in} max.

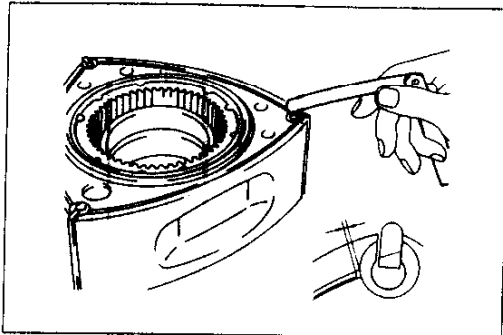

97U0CX-100

6. Check the clearance between the side seal and the corner seal.

Standard clearance:

0.05–0.15 mm {0.0020–0.0059 in}

Clearance: 0.40 mm {0.016 in} max.

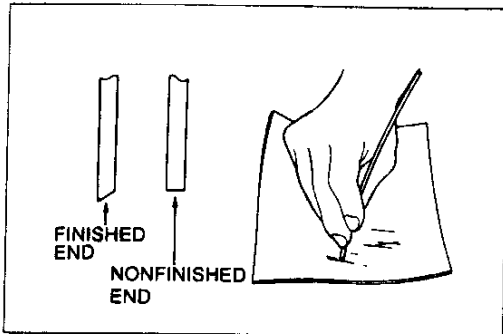

67U01X-117

7. If necessary, replace the side seal. Adjust the clearance between the side seal and corner seal by carefully lapping the nonfinished end.

Adjusted clearance:

0.05–0.15 mm {0.002–0.0059 in}

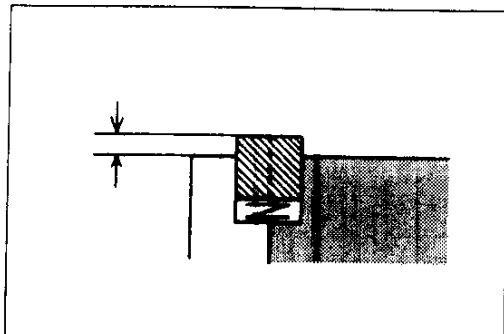

67U01X-118

Corner Seal

1. Inspect the corner seal and soft seal for wear, cracks, and other damage. If necessary, replace them.
2. Install the corner seal spring and corner seal into its respective groove.
3. Check the corner seal for free vertical movement.
4. Check the corner seal protrusion.

Protrusion: 0.5 mm {0.020 in} min.

5. If necessary, replace the corner seal and/or the spring.

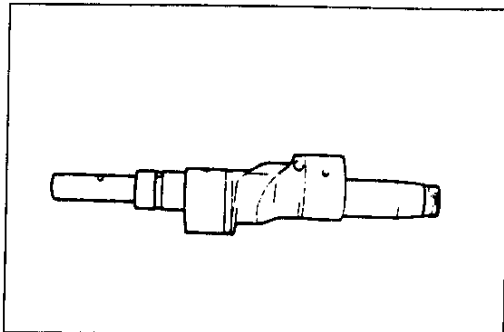

67U01X-119

Eccentric Shaft

1. Check the eccentric shaft for cracks, scoring, wear, and other damage.
2. Verify that the oil passages are open.

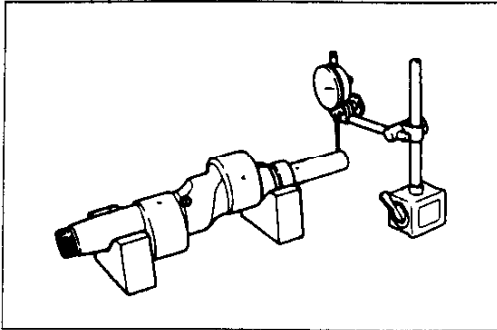

17U0CX-016

3. Check the eccentric shaft runout. Measure the run-out at the end of the shaft, and replace it if necessary.

Runout: 0.06 mm {0.0024 in} max.

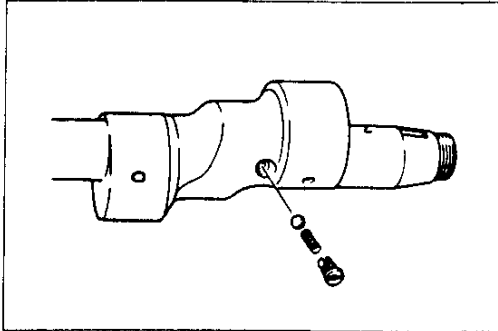

97U0CX-101

4. Check the oil jet spring for weakness, and check for sticking and damage of the steel ball.

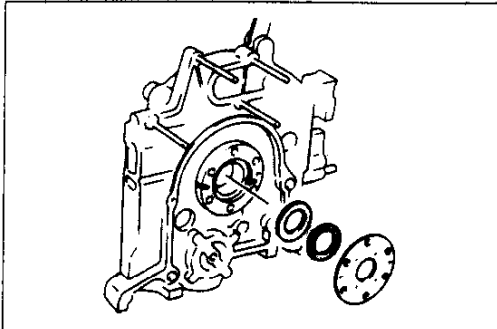

67U01X-122

Needle Bearing and Thrust washer

1. Check the needle bearing for wear and damage.
2. Check the bearing housing and thrust plate for wear and other damage.

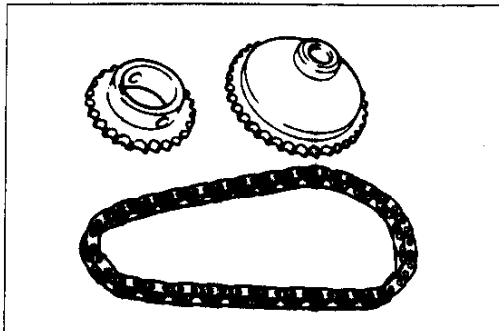

67U01X-123

Oil Pump Drive Chain and Sprocket Wheel

1. Check the oil pump drive chain for broken links.
2. Check the oil pump drive sprocket and driven sprocket for cracks and worn or damaged teeth. If necessary, replace with new parts.

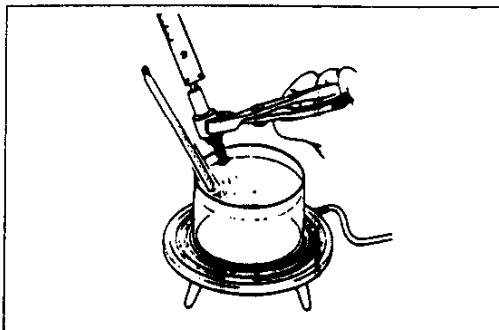

37U0CX-139

Eccentric Shaft Bypass Valve

1. Place the eccentric shaft bypass valve in oil and heat up the oil gradually.
2. Check the protrusion of the valve at **60°C {140°F}**.



Protrusion: 6 mm {0.24 in} min.

3. If not as specified, replace the bypass valve.

ASSEMBLY

PREPARATION

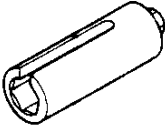
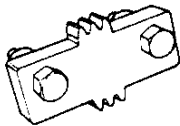
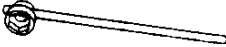
SST

<p>49 H018 001</p> <p>Wrench, knock sensor</p> 	<p>For installation of knock sensor</p>	<p>49 F011 101</p> <p>Brake, ring gear</p> 	<p>For prevention of engine rotation</p>
<p>49 0820 035</p> <p>Box wrench, flywheel</p> 	<p>For removal / installation of locknut</p>	<p>49 1881 055A</p> <p>Stopper counter weight</p> 	<p>For prevention of engine rotation</p>

37U0CX-14C

1. Clean all parts before reinstallation.
2. Apply clean engine oil to all sliding and rotating parts.
3. Install identical parts (such as rotor seals, seal springs, rotor oil seals, and rotor) in the exact positions from which they were removed.
4. Replace plain bearings if they are peeling, burned, or otherwise damaged.
5. Tighten all bolts and nuts to the specified torques.

Caution

- Do not reuse gaskets or oil seals.

97U0CX-1-33

HOUSING (ROTOR)

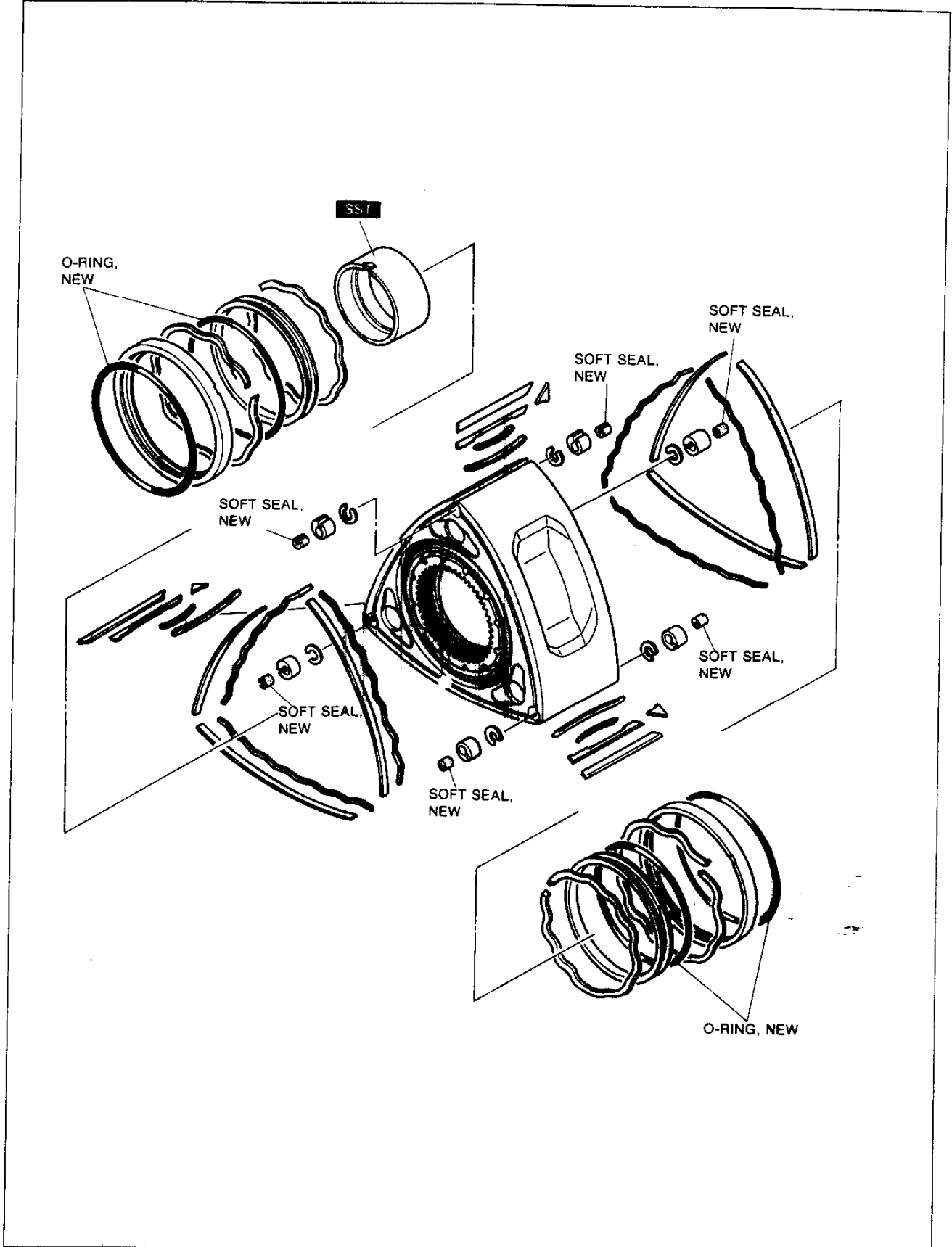

37U0CX-141

HOUSING (INTERNAL PARTS)
Torque Specifications

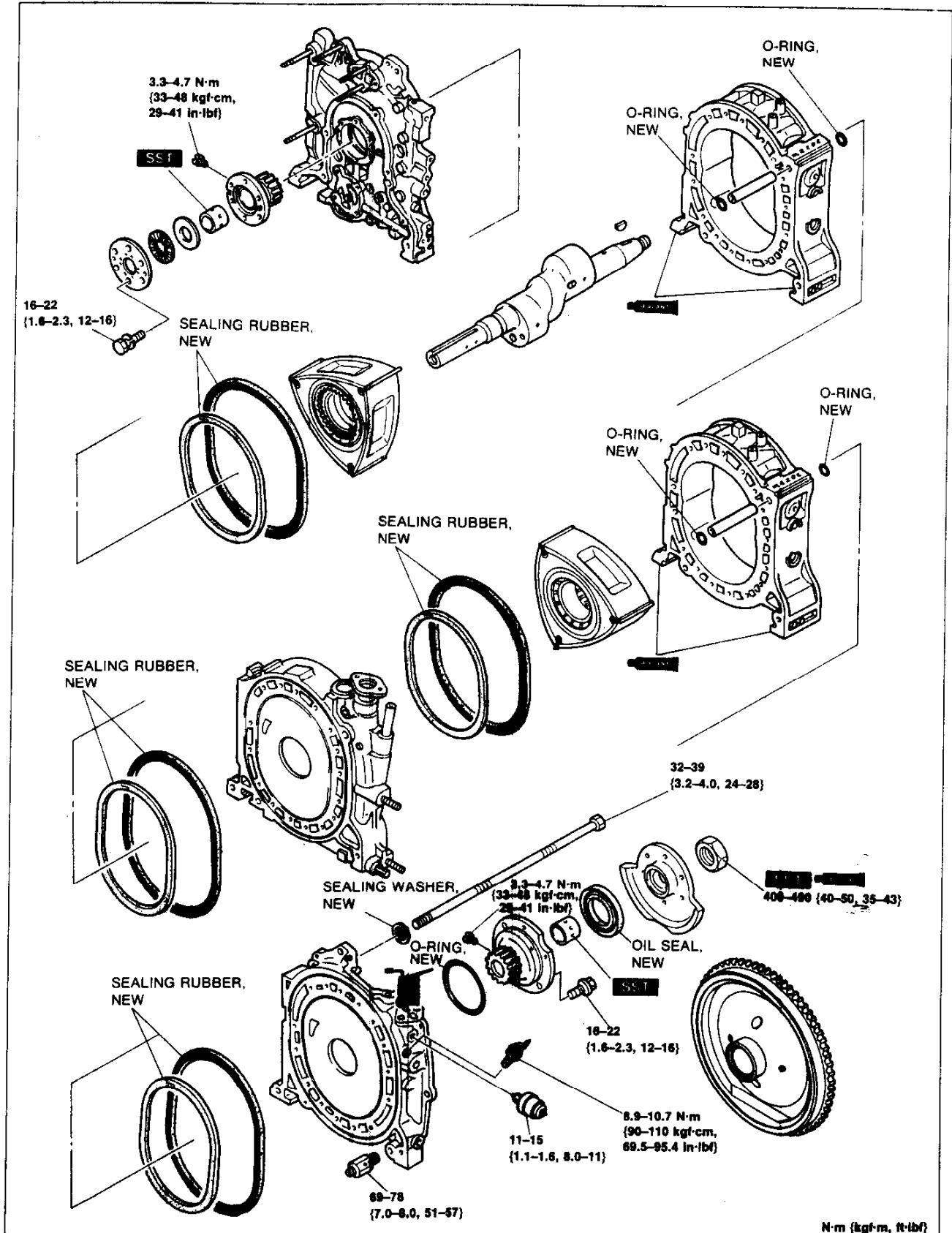

37UOCX-142

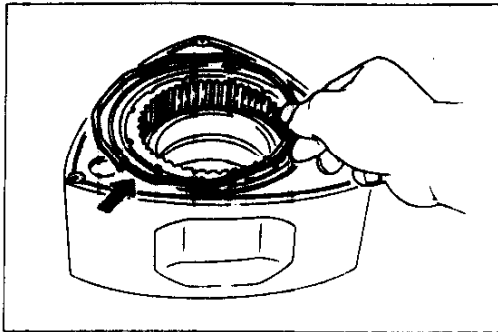

97U0CX-106

Rotor Oil Seal

Note

- When replacing the oil seal, first make sure that it moves smoothly in the groove without the O-ring in place.
- Be careful not to deform the lip of the oil seal.

1. Install the oil seal springs in their respective grooves on the rotor with the round edge of the spring fitted in the stopper hole of the oil seal grooves.

Note

- The oil seal springs are identified by a paint mark.
Cream for front faces of front and rear rotors.
Blue for rear faces of front and rear rotors.

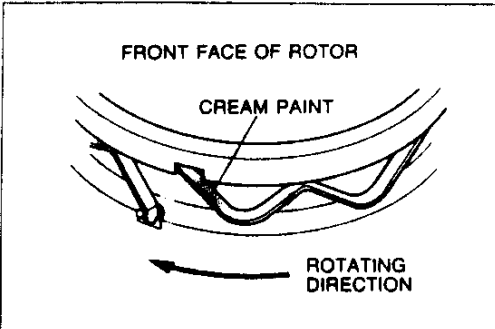

67U01X-126

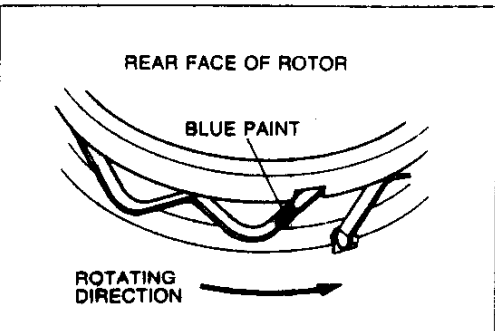

97U0CX-107

2. Apply engine oil to the new O-ring.
3. Install the O-ring in the oil seal.
4. Place the inner oil seal in the oil seal groove so that the square edge of the spring fits into the notch of the oil seal.

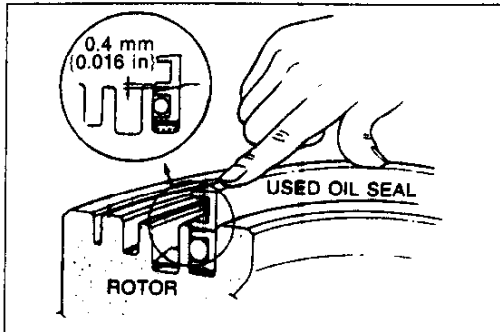

37U0CX-143

5. Press in the oil seal by using a used oil seal until the lip of the new oil seal is approximately **0.4 mm {0.016 in}** below the surface of the rotor.
6. Push the oil seal slowly by hand and make sure it moves freely.

Front Housing

1. Mount the front housing to the **SST**.
2. Position the thrust plate with the chamfer facing toward the front housing. Install the needle bearing and plate.

Tightening torque:

16–22 N·m {1.6–2.3 kgf·m, 12–16 ft·lbf}

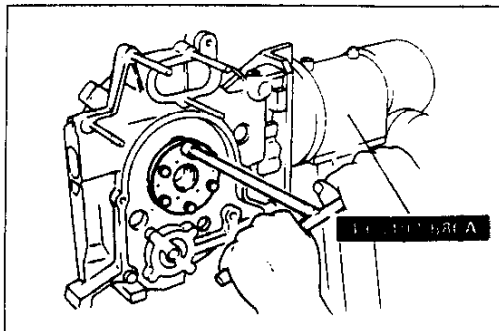

37U0CX-144

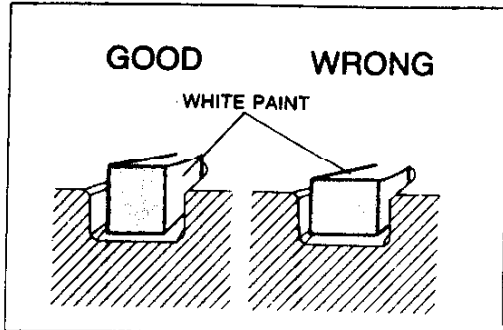

67U01X-130

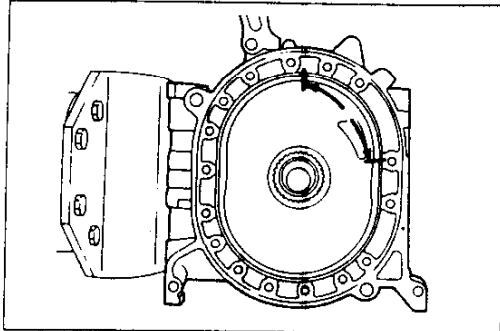

67U01X-131

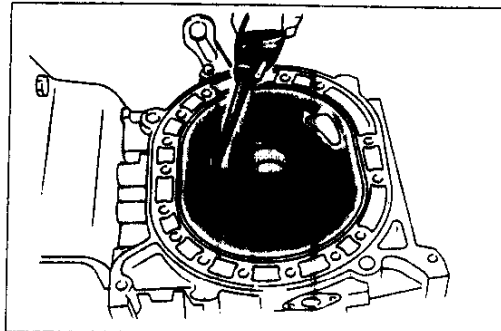

67U01X-132

3. Apply petroleum jelly to the new outer and inner sealing rubbers.
4. Install the outer sealing rubber so that the white paint faces the side wall of the groove.

5. Install the inner sealing rubber so that the blue paint faces the outer wall of the groove and so that the seam is placed within the position as shown in the figure.
6. Check that the outer and inner sealing rubbers are not twisted.

7. Apply engine oil to the contact surfaces, stationary gear, and main bearing.

Caution

- Do not apply engine oil to the sealing rubber.

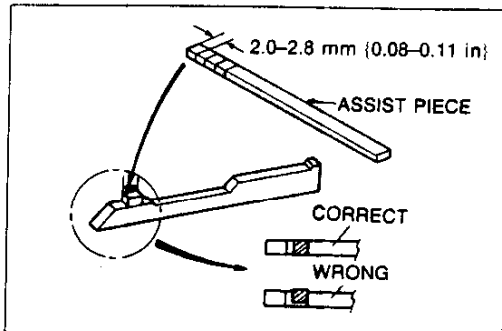

37U0CX-145

Rotor Seals (Front side of rotor)

1. Place the front rotor on a clean rubber pad or cloth with the front side upward.
2. Cut the assist piece with a razor knife so that it is **2.0-2.8 mm {0.08-0.11 in}** long.
3. Peel the paper off the assist piece and stick it onto the apex seal:

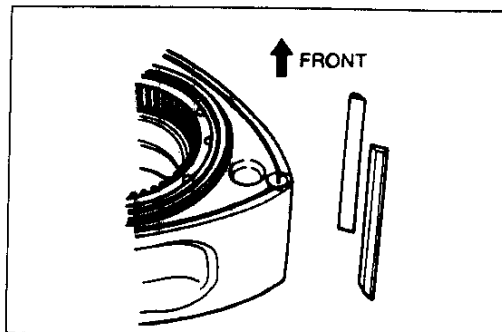

97U0CX-111

4. Install the upper and lower apex seals without the spring and side piece into their respective grooves so that the side piece mounting is at the rear side of the rotor.

Caution

- If the apex seals are installed incorrectly, this may result in poor gas sealing.

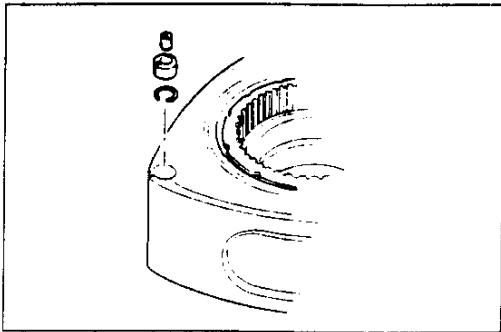

97U0CX-112

5. Install the new soft seals into the corner seals.
6. Install the corner seal springs and corner seals so that the chamfered surfaces face the bottom of the groove.

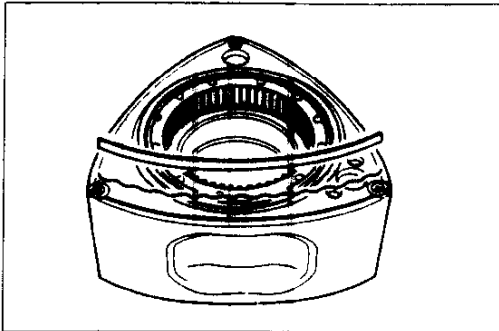

97U0CX-113

7. Install the side seal springs and side seals so that the paint mark faces the bottom of the groove.
8. Confirm smooth movement of the corner seals and side seals by lightly pressing them.
9. Apply petroleum jelly to the side seals.

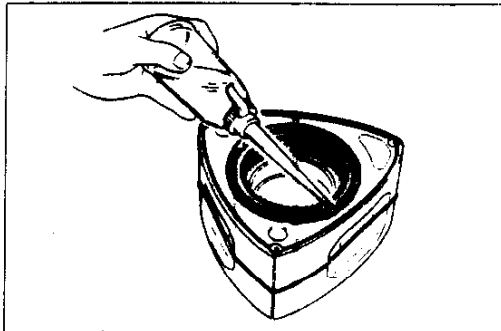

67U01X-136

Front Rotor

1. Apply clean engine oil to the rotor oil seal, rotor bearing, and internal gear.

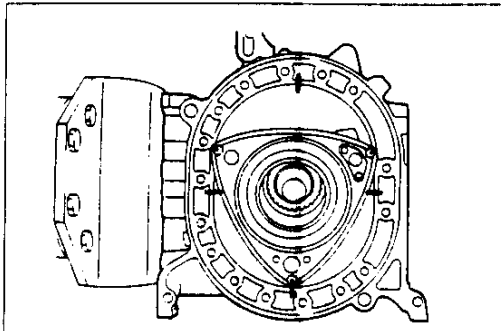

67U01X-137

2. Place the front rotor in the front housing, and mesh the internal gear and stationary gear so that one of the rotor apices is set to one of the four positions illustrated.

Caution

- Do not place the rotor on the sealing rubber.

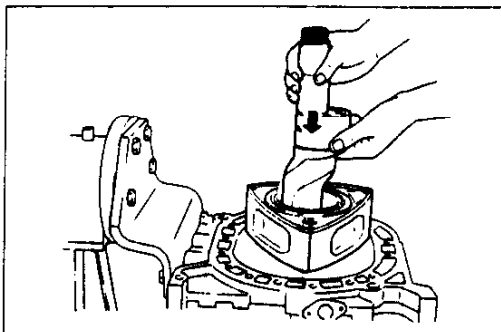

37U0CX-146

Eccentric Shaft

1. Apply clean engine oil to the front rotor journal and main journal.
2. Insert the eccentric shaft, being careful not to damage the rotor bearing or the main bearing.

C

ASSEMBLY

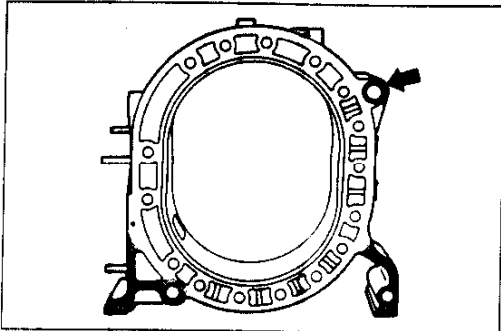

77U01X-122

Front Rotor Housing

1. Apply petroleum jelly to the new O-ring, and install it to the rotor housing.
2. Apply sealant to the rotor housing front side, as shown by the shaded areas in the figure.

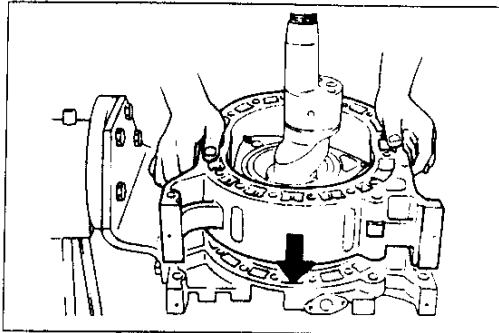

77U01X-123

3. Apply clean engine oil to the trochoid (chamber) surface of the rotor housing.
4. Install the rotor housing.

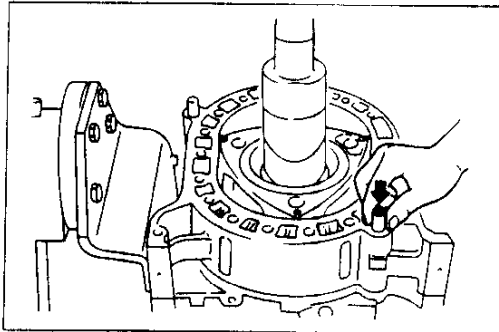

77U01X-124

5. Apply clean engine oil to the tubular dowels and insert them through the front rotor housing holes into the housing holes.

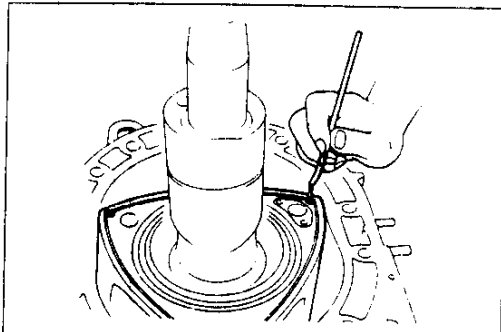

67U01X-142

Rotor Seals (Rear side of rotor)

1. Insert the short apex seal springs.

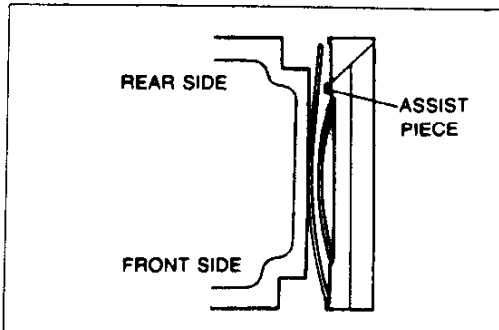

97U0CX-116

2. Insert the long apex seal springs.
3. Fit each side piece into its original position and confirm that the springs are set correctly on the side pieces.
4. Confirm smooth movement of each seal by pressing its head.

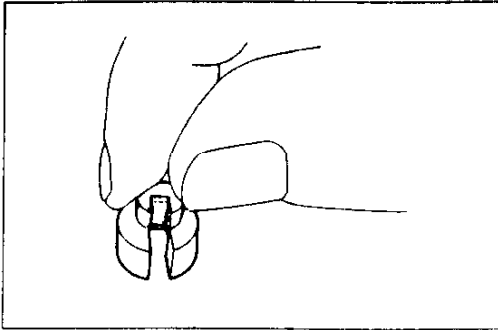

97U0CX-117

5. Install the new soft seals into the corner seals.
6. Install the corner seal springs and corner seals so that the chamfered surfaces face the bottom of the groove.

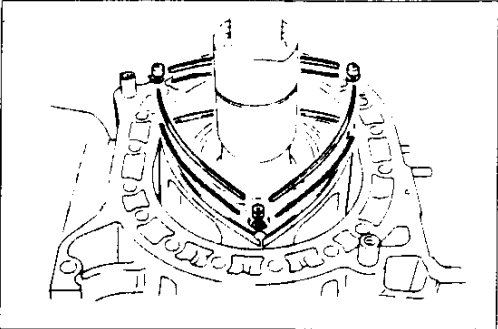

97U0CX-118

7. Install the side seal springs and side seals so that the paint mark faces the bottom of the groove.
8. Confirm smooth movement of the corner seals and side seals by lightly pressing them

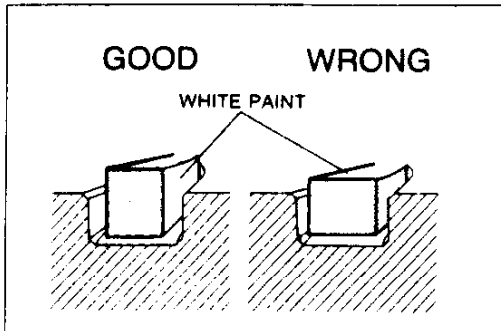

67U01X-146

Intermediate Housing

1. Apply petroleum jelly to the new outer and inner sealing rubbers.
2. Install the outer sealing rubber to the front side so that the white paint faces the side wall of the groove.

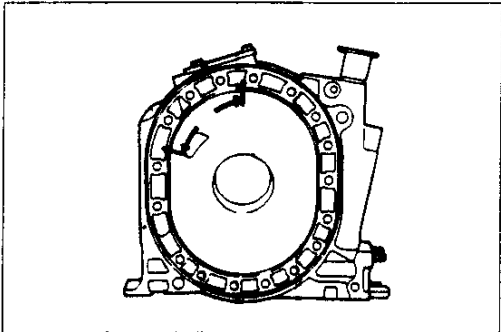

67U01X-147

3. Install the inner sealing rubber to the front side so that the blue paint faces the outer wall of the groove and so that the seam is placed within the position shown in the figure.
4. Check that the outer and inner sealing rubbers are not twisted.

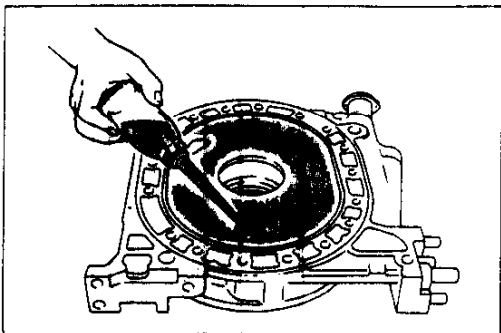

87U01X-010

5. Apply clean engine oil to the contact surfaces of the intermediate housing.

Caution

- Do not apply engine oil to the sealing rubber.

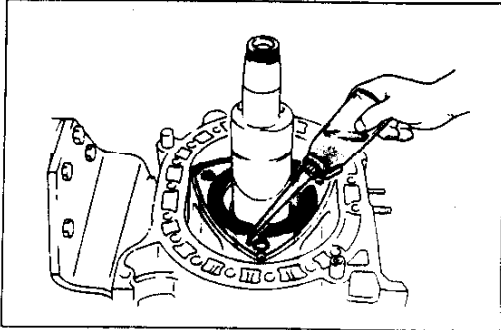

67U01X-149

6. Apply clean engine oil to the rotor oil seal on the rear side of the front rotor.

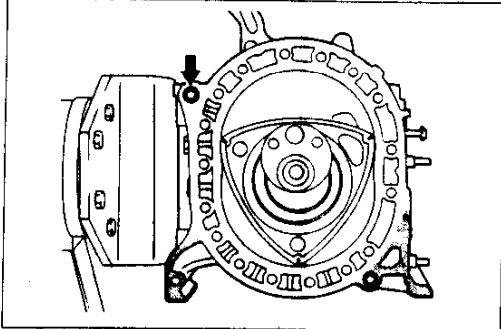

97U0CX-119

7. Apply petroleum jelly to a new O-ring, and install it on the rotor housing.
8. Apply sealant to the shaded areas as shown in the figure.

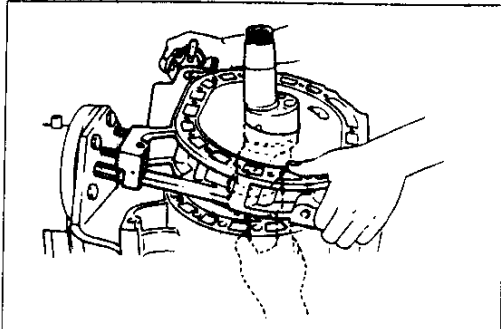

97U0CX-120

9. Turn the eccentric shaft so that the rear rotor journal faces the intake and exhaust side.
10. Lift the eccentric shaft about **25 mm {1.0 in}**, and install the intermediate housing over the eccentric shaft and onto the front rotor housing.

Note

- Do not lift the shaft over **35 mm {1.4 in}**.

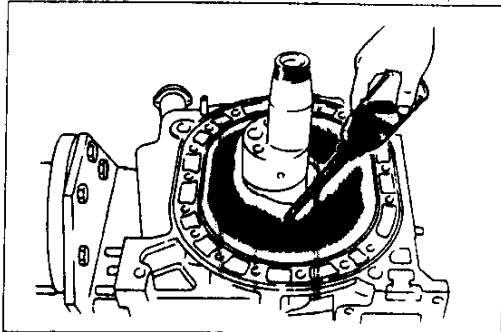

67U01X-152

11. Install the outer and inner sealing rubber to the rear side of the intermediate housing using the same method as for the front side of the intermediate housing.
12. Apply clean engine oil to the rear contact surfaces.

Caution

- Do not apply engine oil to the sealing rubber.

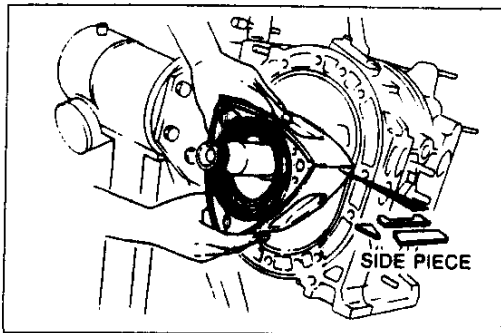

37U0CX-147

Rear Rotor, Rotor Seals, and Rear Rotor Housing

Install the rotor seals, rear rotor, and rear rotor housing by using the same procedure as for the installation of the rotor seals, front rotor, and front rotor housing.

1. Install the rotor seals and rear rotor.
(Refer to page C-64.)

Caution

- The side piece of the rotor seal must face the rear housing side.

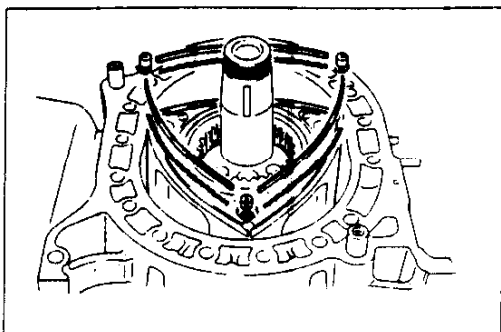

37U0CX-148

2. Install the rear rotor housing. (Refer to page C-66.)
3. Install the tubular dowels.
4. Install the rotor seals at the side of the rotor. (Refer to page C-66.)

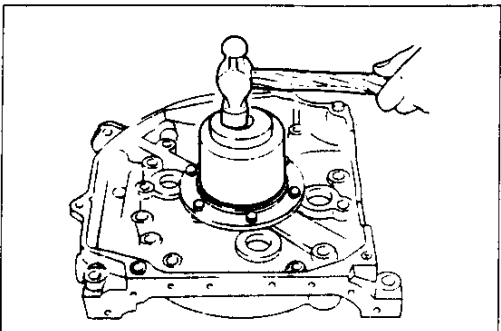

67U01X-155

Rear Housing

1. Apply clean engine oil to a new rear oil seal and the groove of the rear stationary gear.
2. Install the oil seal into the rear stationary gear.

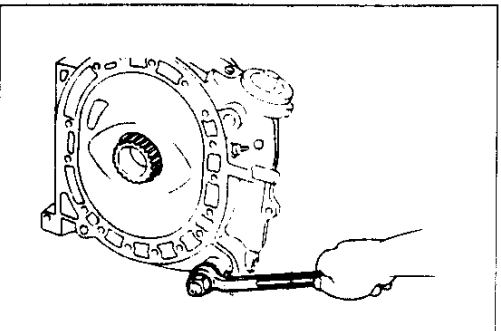

37U0CX-149

3. Install the oil regulator valve.

Tightening torque:

69-78 N·m {7.0-8.0 kgf·m, 51-57 ft·lbf}

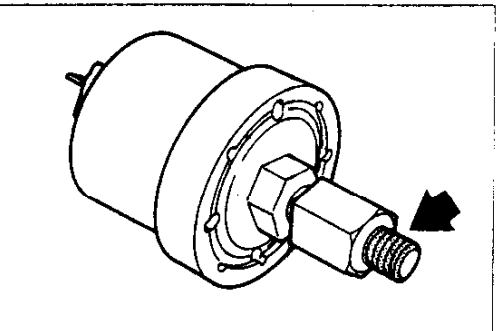

37U0CX-150

4. Apply sealant to the oil pressure switch threads and install the oil pressure switch.

Caution

● Do not allow sealant in the pressure switch hole.

Tightening torque:

10.8-15.6 N·m {110-160 kgf·cm, 96-138 in·lbf}

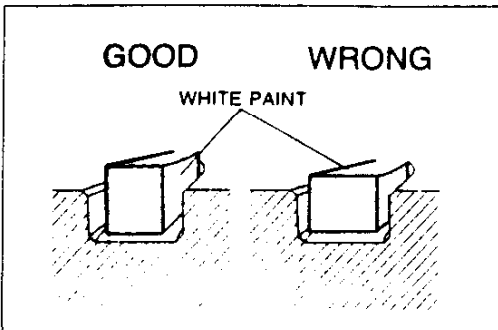

67U01X-157

5. Apply petroleum jelly to the new outer and inner sealing rubbers.
6. Install the outer sealing rubber so that the white paint faces the side wall of the groove.

C

ASSEMBLY

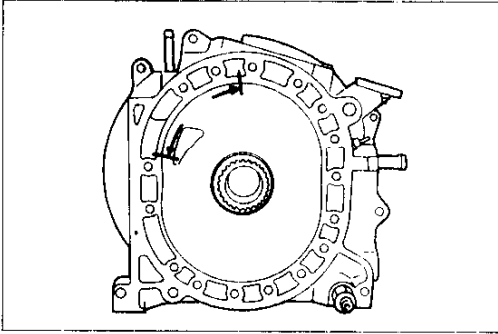

67U01X 158

7. Install the inner sealing rubber so that the blue paint faces the outer wall of the groove and so that the seam is placed within position shown in the figure.
8. Verify that the outer and inner sealing rubbers are not twisted.

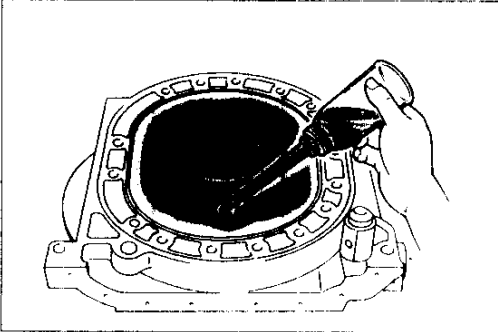

67U01X 159

9. Apply clean engine oil to the contact surfaces, stationary gear, and main bearing.

Caution

- Do not apply engine oil to the sealing rubber.

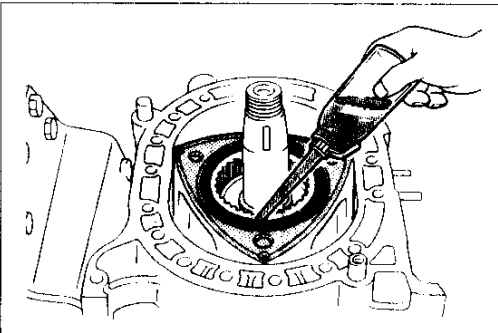

67U01X 160

10. Apply clean engine oil to the rotor oil seal of the rear side of the rotor.

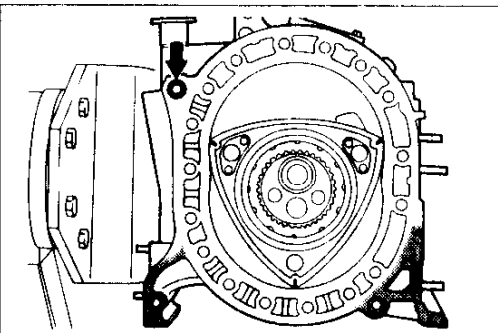

37U0CX 151

11. Apply petroleum jelly to a new O-ring and fit it into the rear rotor housing.
12. Apply sealant to the shaded areas as shown in the figure.

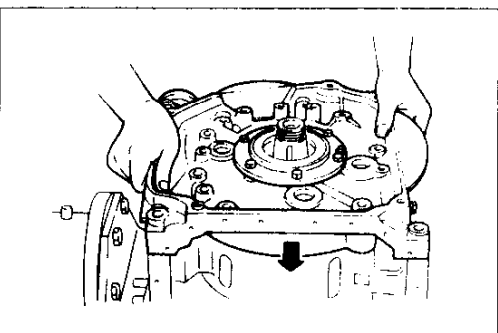

67U01X 162

13. Install the rear housing on the rear rotor housing.
14. Verify that the side pieces of the front and rear apex seals are not wedged between the rotor housing and side housing.

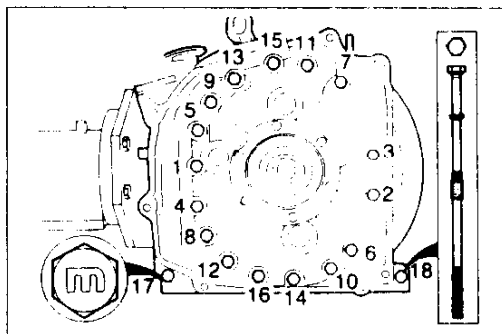

37U0CX-152

Tension Bolt

1. Apply clean engine oil to new seal washers and install them on the tension bolts.
2. Apply clean engine oil to the bolt threads.
3. Install the tension bolts and tighten them gradually in the order shown in the figure.

Tightening torque:

32–39 N·m {3.2–4.0 kgf·m, 24–28 ft·lbf}

Note

- The bolt with the “m” mark is for the No. 17 position.
- The bolt with the protector tube is for the No. 18 position.

4. Turn the eccentric shaft and make sure that it rotates easily and smoothly.

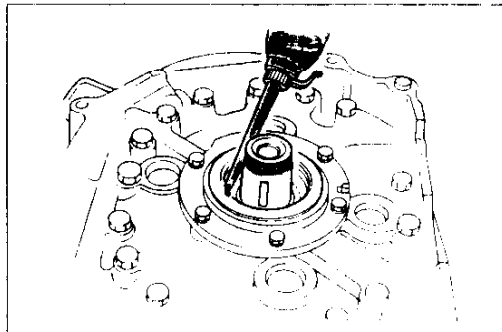

97U0CX-126

Flywheel (MT)

1. Apply clean engine oil to the oil seal in the rear housing.
2. Fit the key to the eccentric shaft.
3. Install the flywheel to the eccentric shaft.

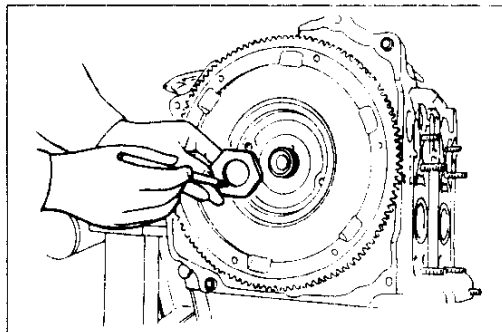

97U0CX-127

4. Apply thread-locking compound to the eccentric shaft threads.
5. Apply sealant to the contact surface of the locknut.

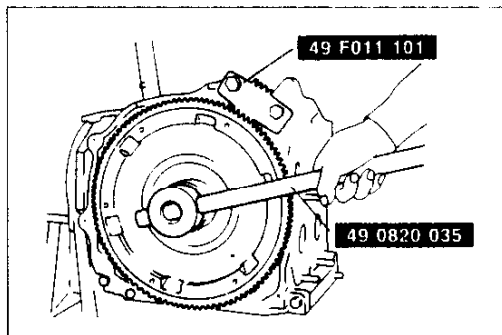

37U0CX-153

6. Install the locknut and tighten it by using the **SST**.

Tightening torque:

400–490 N·m {40–50 kgf·m, 290–360 ft·lbf}

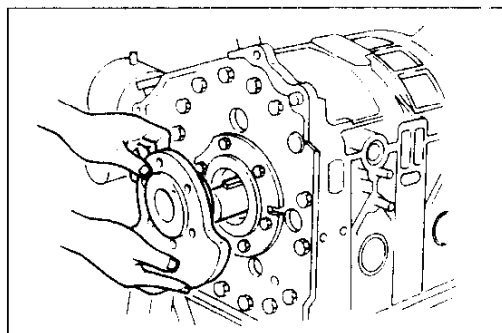

17U0CX-124

Counterweight and Drive Plate (AT)

1. Apply clean engine oil to the oil seal in the rear housing.
2. Fit the key into the eccentric shaft.
3. Install the counterweight onto the eccentric shaft.

Caution

- Take care not to damage the seal.

C

ASSEMBLY

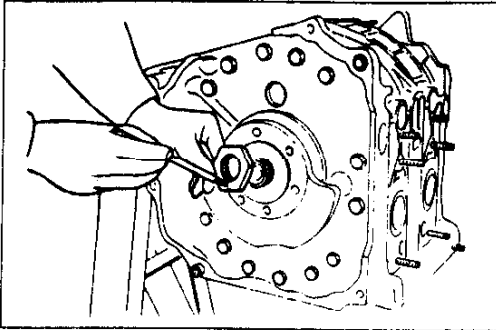

97U0CX-130

4. Apply thread-locking compound to the eccentric shaft threads.
5. Apply sealant to the contact surface of the locknut.

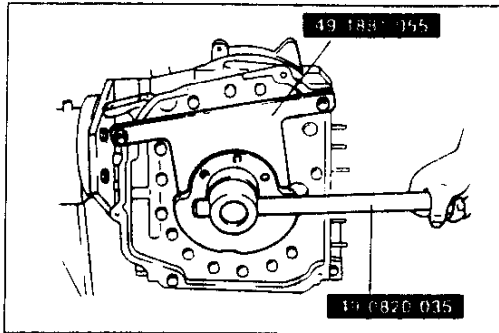

37U0CX-154

6. Install the locknut and tighten it by using the **SST**.

Tightening torque:

400-490 N·m (40-50 kgf·m, 290-360 ft·lbf)

HOUSING (EXTERNAL PARTS II)

Torque Specifications

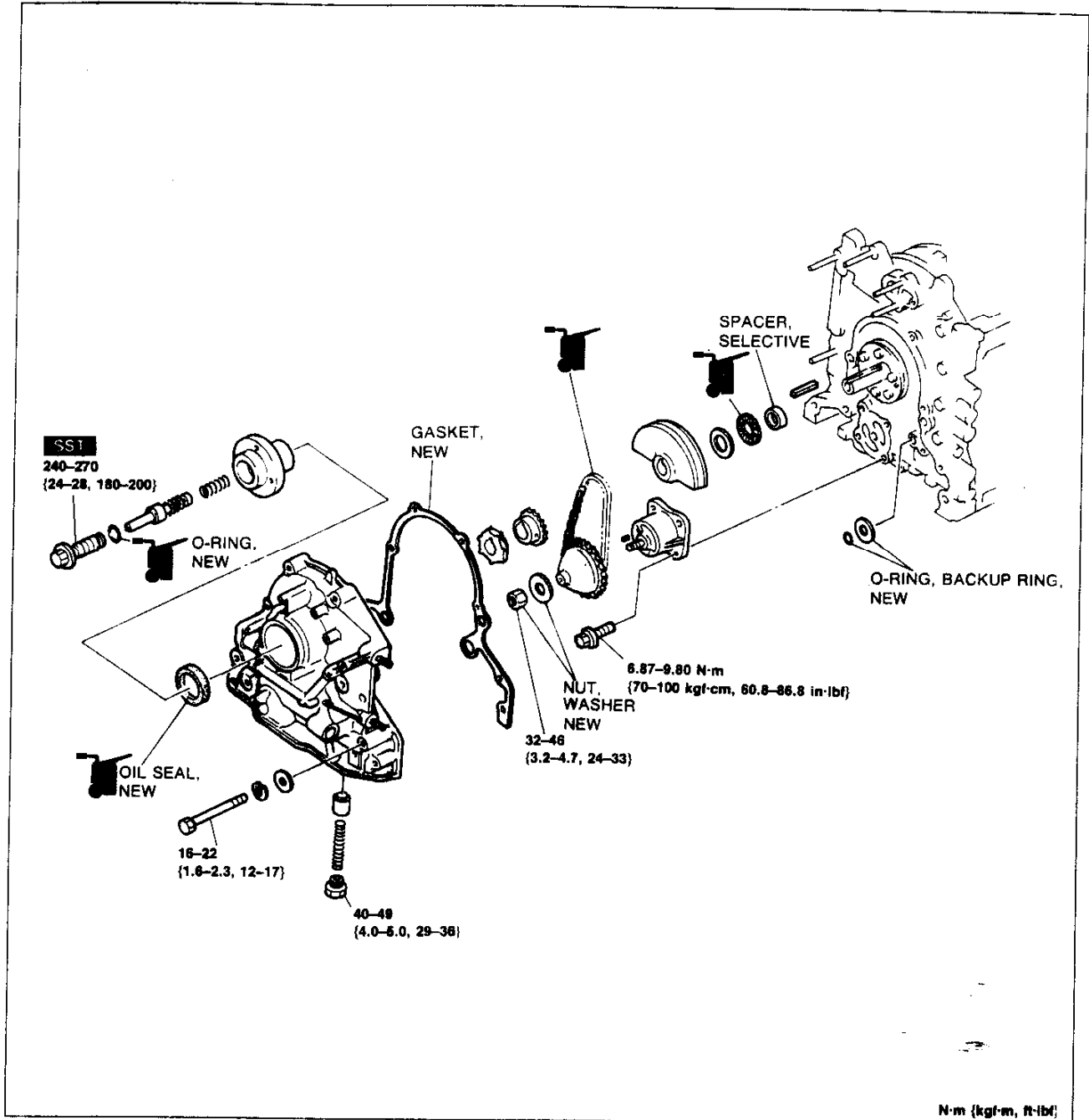

37U0CX-135

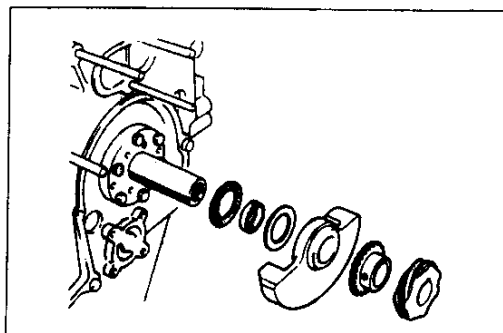

67U01X-171

Balance Weight, Bearing, and Spacer

1. Install the following parts to the eccentric shaft:

- (1) Spacer
- (2) Thrust needle bearing
- (3) Thrust washer
- (4) Balance weight
- (5) Oil pump drive sprocket
- (6) Drive gear

C

ASSEMBLY

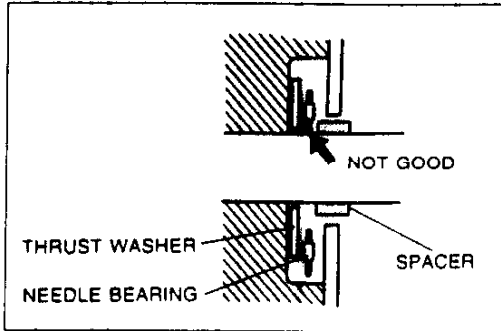

97U0CX 132

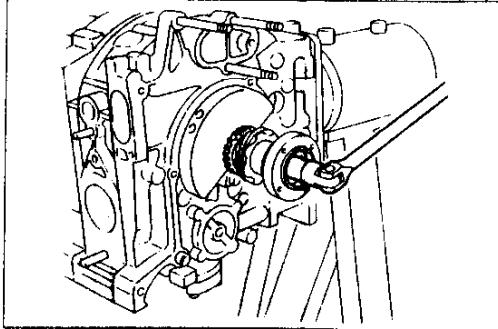

37U0CX 156

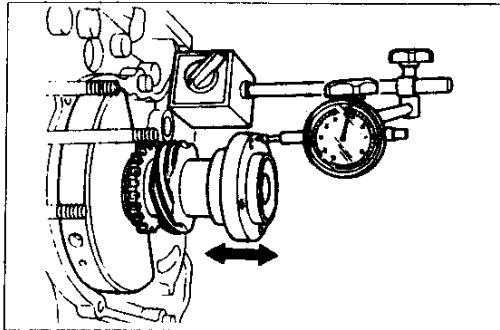

37U0CX-157

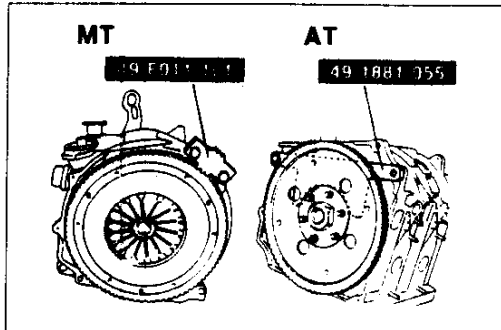

37U0CX-158

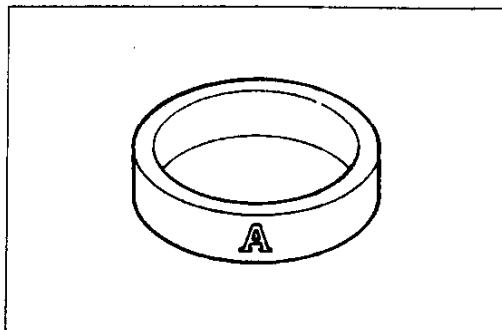

37U0CX-159

Caution

- When installing the needle bearing, make sure it is not caught by the spacer.

2. Install the eccentric shaft pulley boss and tighten the new pulley lock bolt.

Tightening torque:

108–132 N·m {11.0–13.5 kgf·m, 79.6–97.6 ft·lbf}

3. Remove the **SST**.

4. Measure the end play of the eccentric shaft.

Standard:

0.040–0.070 mm {0.0016–0.0028 in}

Maximum:

0.09 mm {0.0035 in} max.

If the end play is not within specification, continue from step 5 and replace the spacer.

5. Attach the **SST** to the flywheel (MT) or to the counterweight (AT).
6. Remove the eccentric shaft lock bolt, drive gear, and oil pump drive sprocket.

7. If the end play is less than specified, replace the spacer with a thicker one. If the end play is more than specified, install a thinner spacer.

Spacer stamp and thickness

Stamp	Thickness	mm {in}	Stamp	Thickness	mm {in}
A	7.975–7.995	{0.3140–0.3147}	D	8.035–8.055	{0.3164–0.3171}
B	7.995–8.015	{0.3148–0.3155}	E	8.055–8.075	{0.3172–0.3179}
C	8.015–8.035	{0.3156–0.3163}			

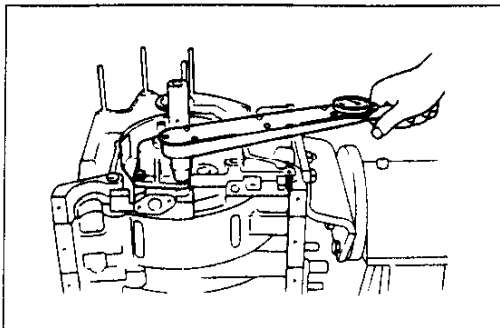

97U0CX-136

Oil pump

1. Apply clean engine oil to the oil pump shaft.
2. Install the oil pump to the front housing.

Tightening torque:

6.87–9.80 N·m {70–100 kgf·cm , 60.8–86.8 in·lbf}

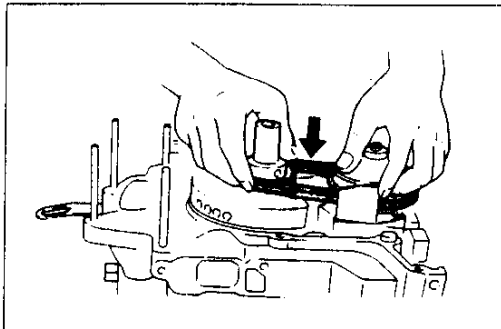

67U01X-179

3. Install the key to the oil pump shaft.
4. Install the oil pump drive gear, driven gear, and drive chain as an assembly.

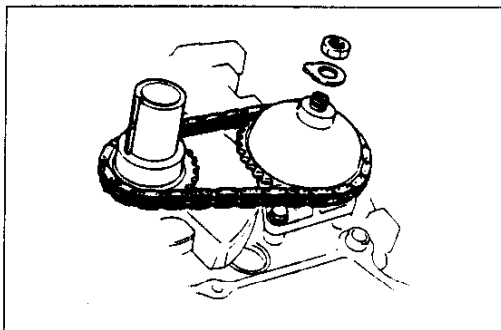

37U0CX-160

5. Install the key to the eccentric shaft.
6. Install a new washer and oil pump locknut.

Tightening torque:

32–46 N·m {3.2–4.7 kgf·m, 24–33 ft·lbf}

7. Bend the washer to lock the nut.

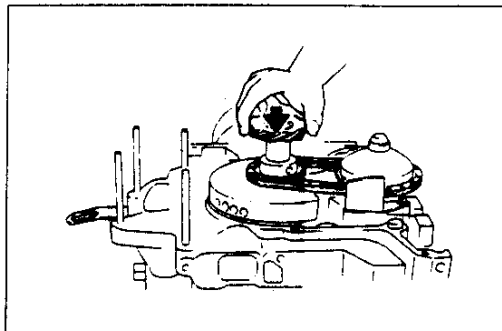

37U0CX-161

8. Install the drive gear so that the chamfered surface faces the housing.

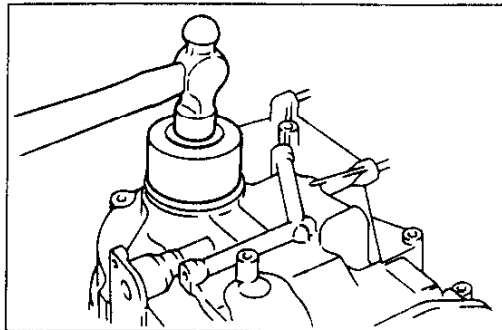

67U01X-182

Front Cover

1. Apply clean engine oil to the new front oil seal and the groove of the front cover.
2. Install the oil seal in the front cover.

C

ASSEMBLY

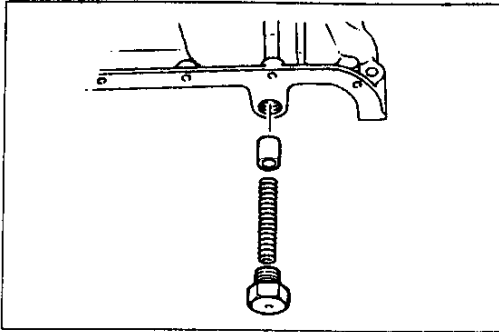

37U0CX-162

3. Install the oil pressure control valve in the front cover.

Tightening torque:

40–49 N·m {4.0–5.0 kgf·m, 29–36 ft·lbf}

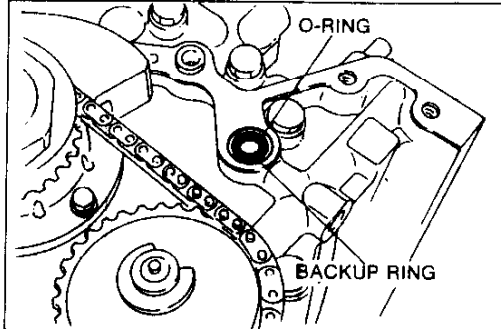

37U0CX-163

4. Apply petroleum jelly to the new O-ring and backup ring.

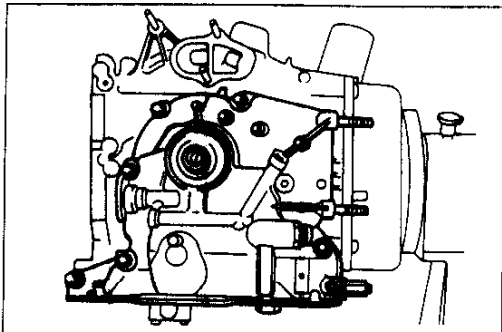

37U0CX-164

5. Install the front cover along with a new gasket.

Tightening torque:

16–22 N·m {1.6–2.3 kgf·m, 12–17 ft·lbf}

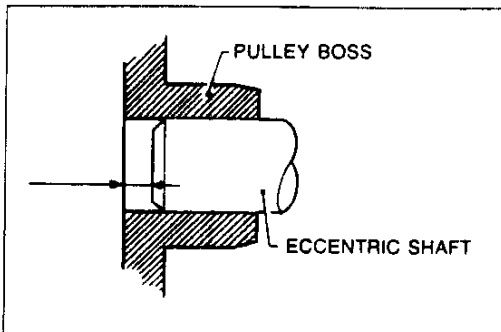

97U0CX-138

Eccentric Shaft Lock Bolt and Bypass Valve

1. Install the eccentric shaft pulley boss.
2. Temporarily install the lock bolt, and tighten it by hand.
3. Remove the lock bolt, and measure the pulley boss protrusion. If it is over the limit, the needle bearing may be caught by the spacer. Remove and reinstall the needle bearing, if necessary.

Protrusion: 2.44 mm {0.0961} max.

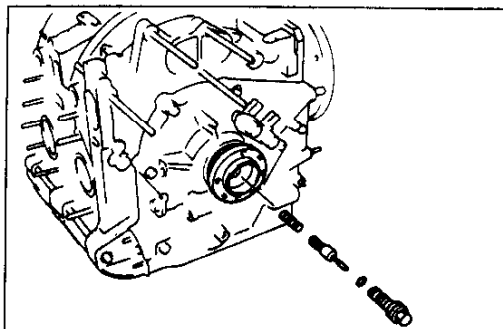

37U0CX-165

4. Install the bypass valve and spring into the eccentric shaft.
5. Apply clean engine oil to the new O-ring and install it on the lock bolt.
6. Apply sealant to the flange face of a new lock bolt.
7. Install the lock bolt.

Tightening torque:

240–270 N·m {24–28 kgf·m, 180–200 ft·lbf}

HOUSING (EXTERNAL PARTS I)
Torque Specifications

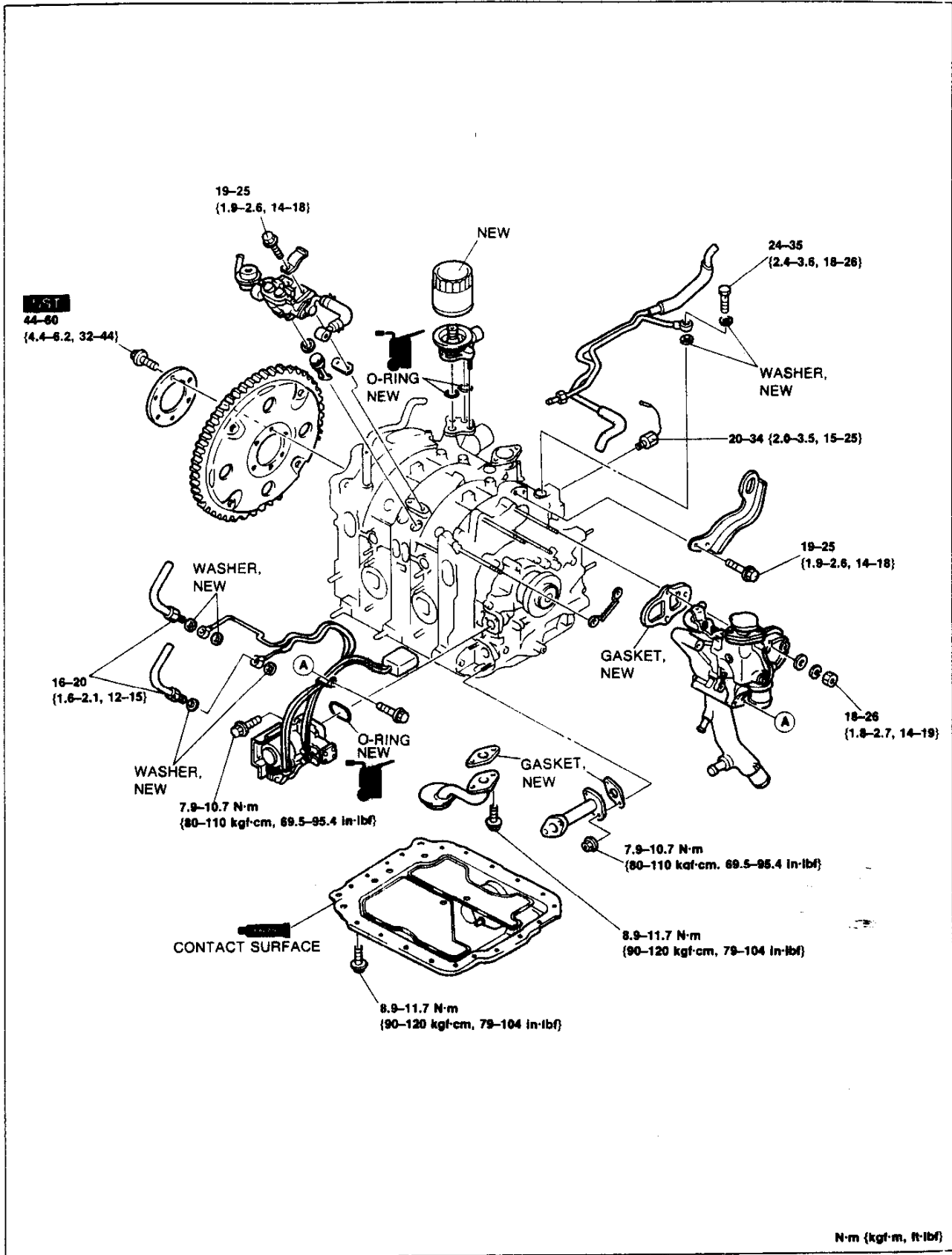

37U0CX-166

C

ASSEMBLY

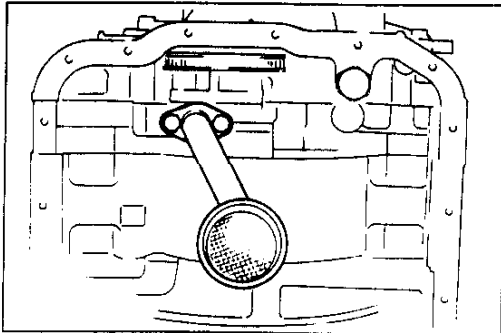

97U0CX-140

Oil Strainer

Install the oil strainer along with a new gasket.

Tightening torque:

8.9–11.7 N·m {90–120 kgf·cm, 79–104 in·lbf}

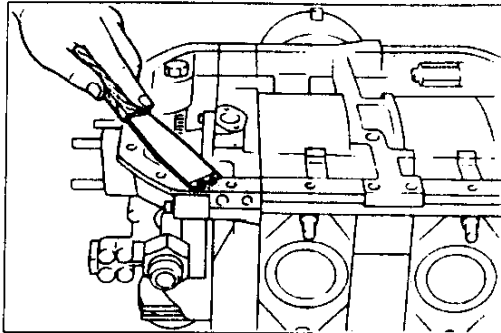

97U0CX-141

Oil Pan

1. Cut away the part of the gasket that projects from between the front cover and the housing.

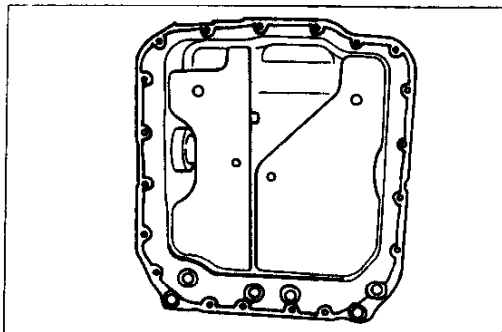

17U0CX-025

2. Clean the mating surface of the housing and oil pan with degreaser and a soft cloth.

3. (Without gasket)

Apply a **4–6 mm {0.16–0.24 in}** diameter bead of sealant around the inside edge of the housing as shown in the figure. It should be continuously applied inboard of the bolt holes, and the ends should overlap.

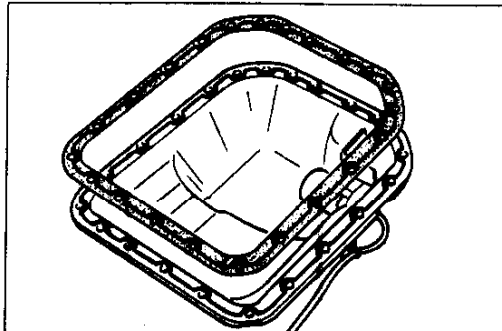

17U0CX-018

(With gasket)

Apply a **4–6 mm {0.16–0.24 in}** diameter bead of sealant around the inside edge of the oil pan and the housing side of the new gasket. It should be continuously applied inboard of the bolt holes, and the ends should overlap.

Caution

- **Install the oil pan within 5 minutes after the sealant is applied.**

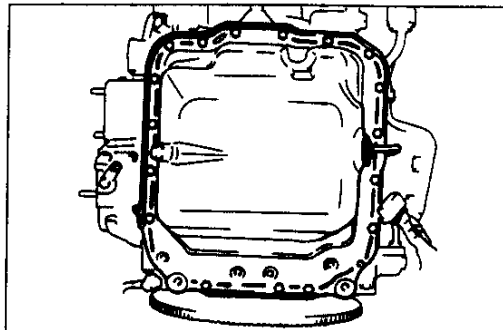

37U0CX-167

4. Install the oil pan and tighten the bolts gradually and evenly.

Tightening torque:

8.9–11.7 N·m {90–120 kgf·cm, 79–104 in·lbf}

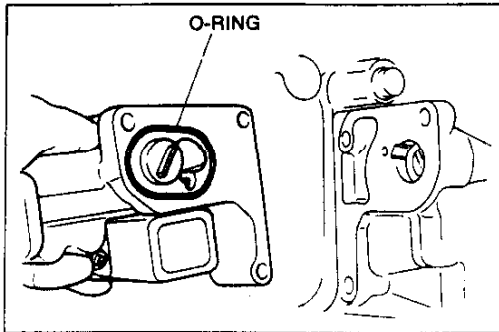

37U0CX-168

Metering oil pump

1. Apply engine oil to the new O-ring.
2. Install the metering oil pump to the front housing.

Tightening torque:

7.9–10.7 N·m {80–110 kgf·cm, 69.5–95.4 in·lbf}

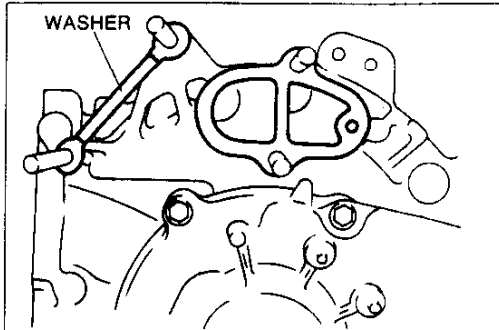

37U0CX-169

Water pump

1. Install the washer and new gasket to the front housing.

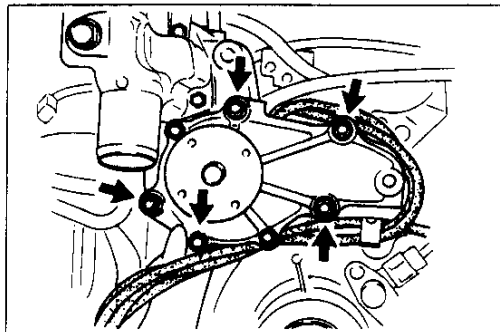

37U0CX-170

2. Install the water pump to the front housing.

Tightening torque:

18–26 N·m {1.8–2.7 kgf·m, 14–19 ft·lbf}

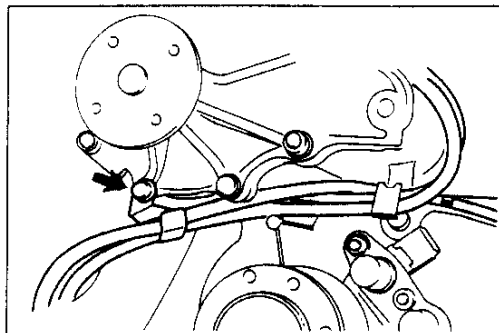

37U0CX-171

3. Install the metering oil pump harness and the metering oil tube to the water pump housing.

Tightening torque:

7.9–10.7 N·m {80–110 kgf·cm, 69.5–95.4 in·lbf}

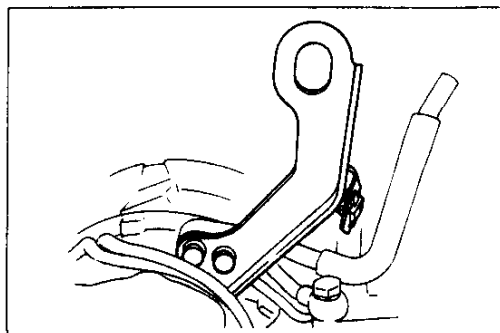

37U0CX-172

Engine hanger

1. Install the engine hanger to the front housing.

Tightening torque:

19–25 N·m {1.9–2.6 kgf·m, 14–18 ft·lbf}

2. Mount the metering oil pump connector to the engine hanger.

C

ASSEMBLY

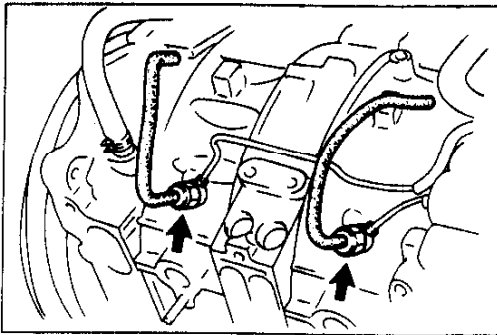

37U0CX-173

Metering oil nozzle

Install the oil nozzles and connect the metering oil tubes using new washers.

Tightening torque:

16–22 N·m {1.6–2.3 kgf·m, 12–16 ft·lbf}

Note

- The oil tube ends are colored.
White : Front rotor housing
Yellow: Rear rotor housing

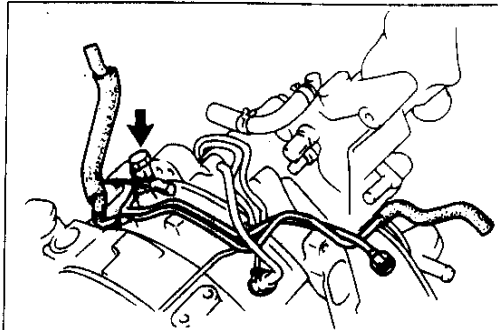

37U0CX-174

Oil inlet pipe

Install the oil inlet pipe and new washers as an assembly and loosely tighten the connecting bolt.

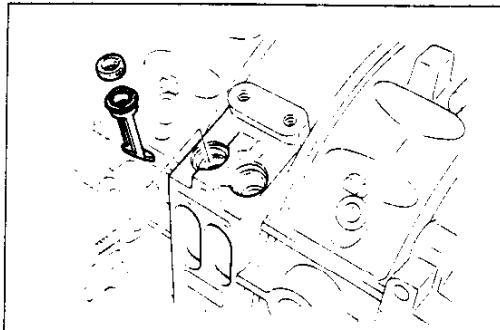

37U0CX-175

Fuel delivery pipe and mixing plate

1. Apply clean engine oil to the air bleed socket.
2. Install the air bleed socket into the engine.

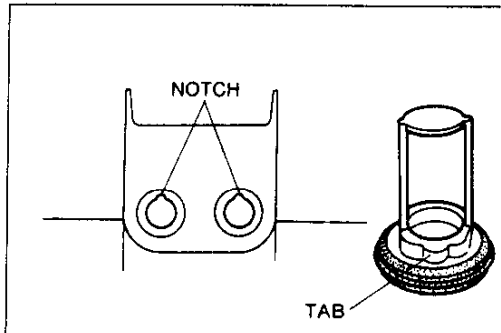

37U0CX-176

Caution

- Install the mixing plate by aligning the mixing plate tab with the housing notch.

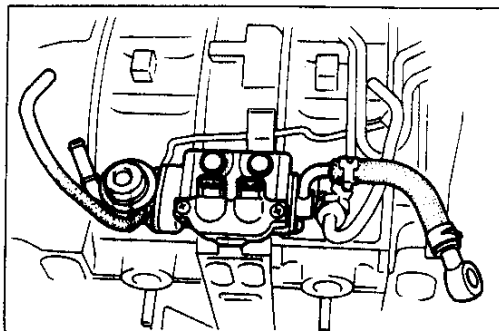

37U0CX-177

3. Install the fuel delivery pipe.

Tightening torque:

19–25 N·m {1.9–2.6 kgf·m, 14–18 ft·lbf}

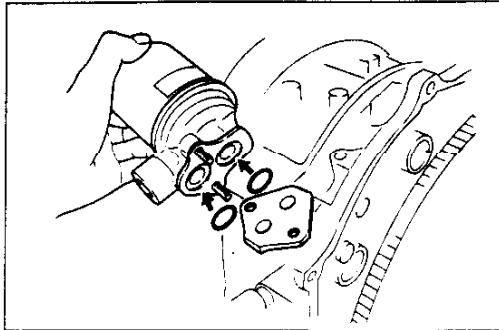

37U0CX-178

Oil filter body

Install the oil filter body along with new O-rings.

Tightening torque:

7.9–10.7 N·m {80–110 kgf·cm, 69.5–95.4 in·lbf}

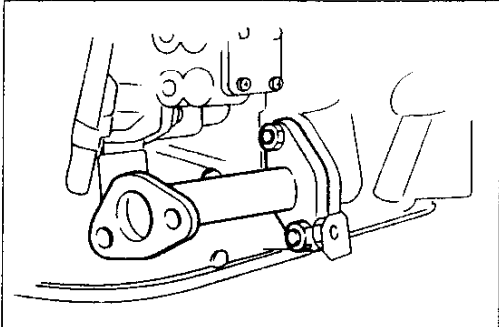

37U0CX-179

Oil pipe

Install the oil pipe along with a new gasket.

Tightening torque:

7.9–10.7 N·m {80–110 kgf·cm, 69.5–95.4 in·lbf}

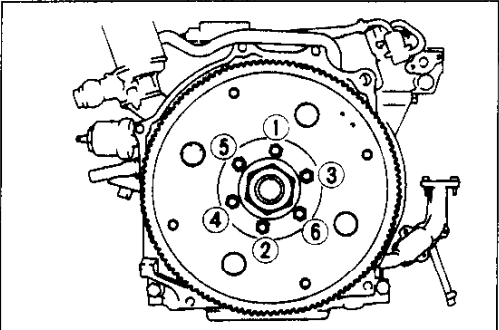

37U0CX-180

Drive plate (AT)

1. Attach the **SST** to the counterweight.
2. Install the drive plate and the back plate.
3. Tighten the bolts in two or three steps in the order shown in the figure.

Tightening torque:

44–60 N·m {4.4–6.2 kgf·m, 32–44 ft·lbf}

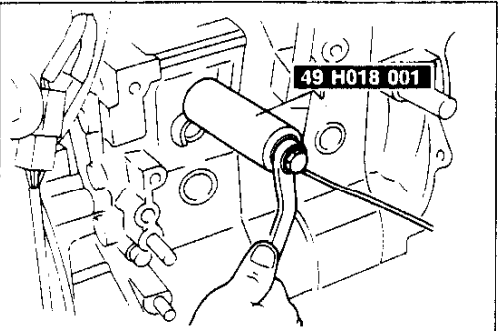

37U0CX-18

Knock sensor

Install the knock sensor and tighten it by using the **SST**.

Tightening torque:

20–34 N·m {2.0–3.5 kgf·m, 15–25 ft·lbf}

C

ASSEMBLY

Harness

Connect the harness connectors shown in the figure.

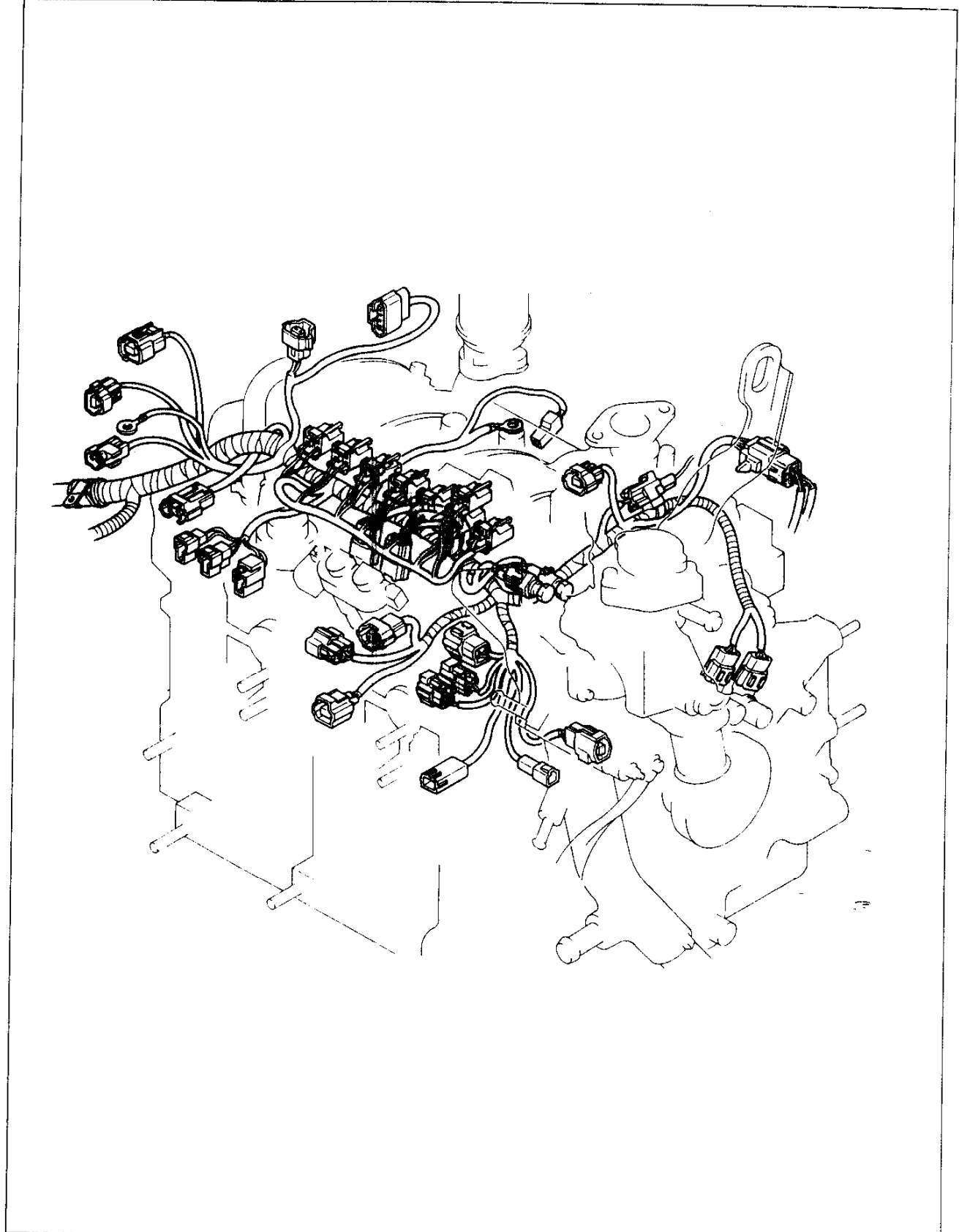

Vacuum pipe assembly

Connect the hoses and connectors shown in the figure.

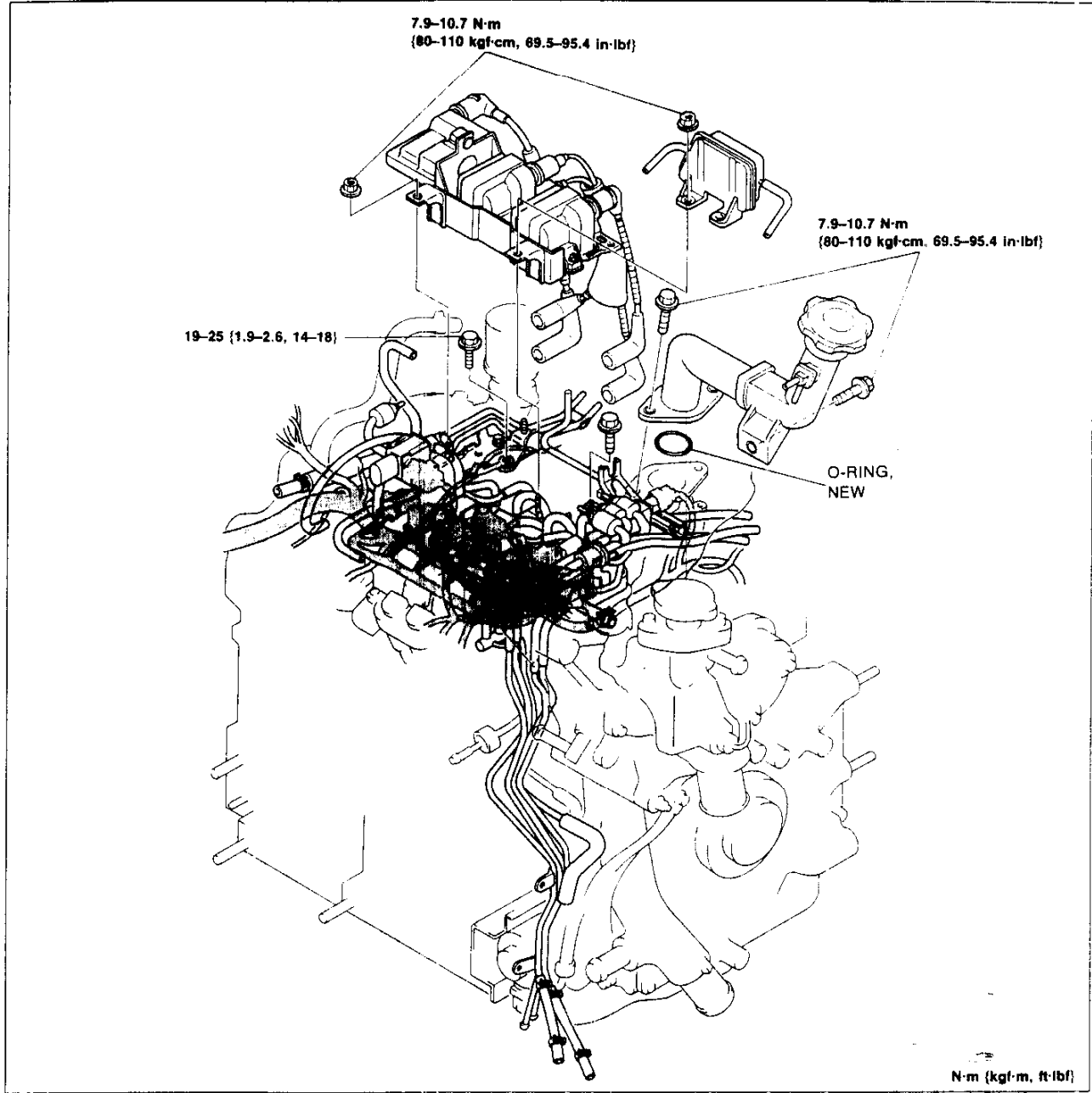

37UOCX-183

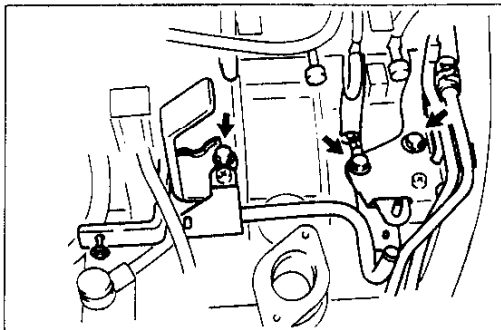

37UOCX-184

Vacuum pipe

1. Install the vacuum pipe and ground harness.

Tightening torque:

19-25 N·m {1.9-2.6 kgf·m, 14-18 ft·lbf}

C

ASSEMBLY

2. Install the harness and hoses as shown in the figure.

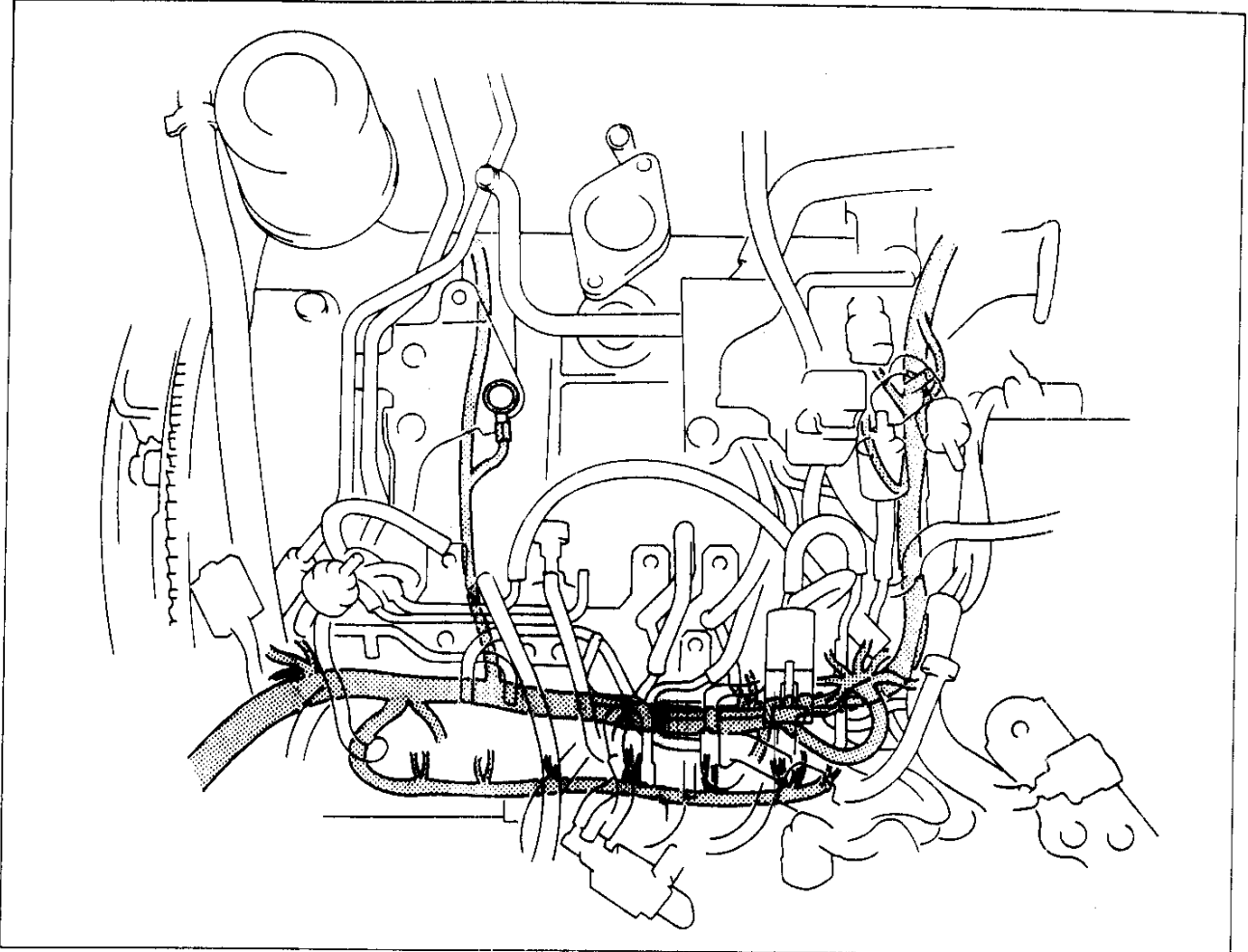

37J0CX-165

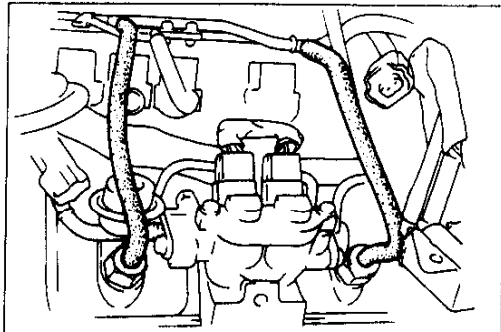

37U0CX-186

3. Connect the vacuum hoses.

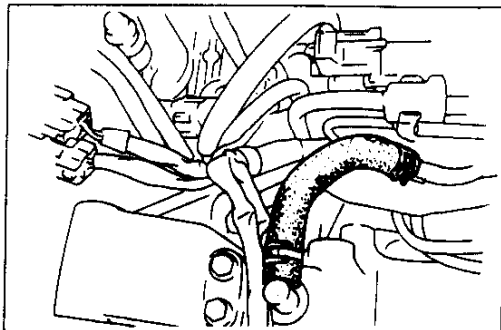

37U0CX-187

4. Connect the water hose.

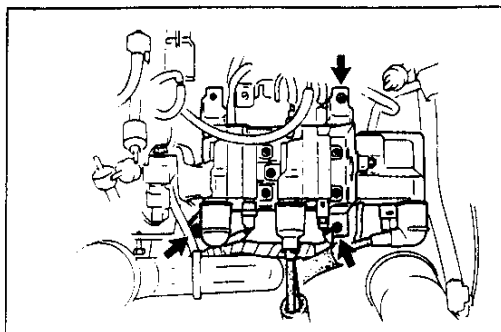

37U0CX-186

Ignition coil assembly and vacuum chamber

1. Install the ignition coil assembly

Tightening torque:

7.9–10.7 N·m {80–110 kgf·cm, 69.5–95.4 in·lbf}

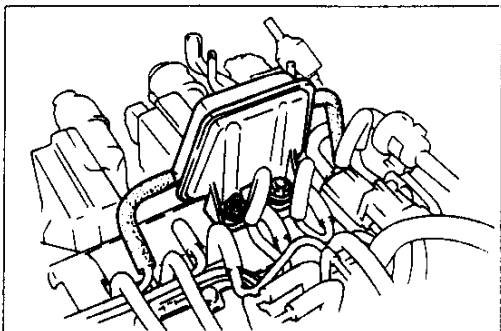

37U0CX-189

2. Install the vacuum chamber.

Tightening torque:

7.9–10.7 N·m {80–110 kgf·cm, 69.5–95.4 in·lbf}

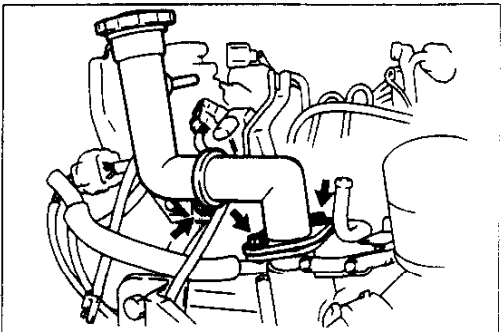

37U0CX-190

Oil filler pipe

Install the oil filler pipe along with a new O-ring.

Tightening torque:

7.9–10.7 N·m {80–110 kgf·cm, 69.5–95.4 in·lbf}

AUXILIARY PARTS (II)
Torque Specifications

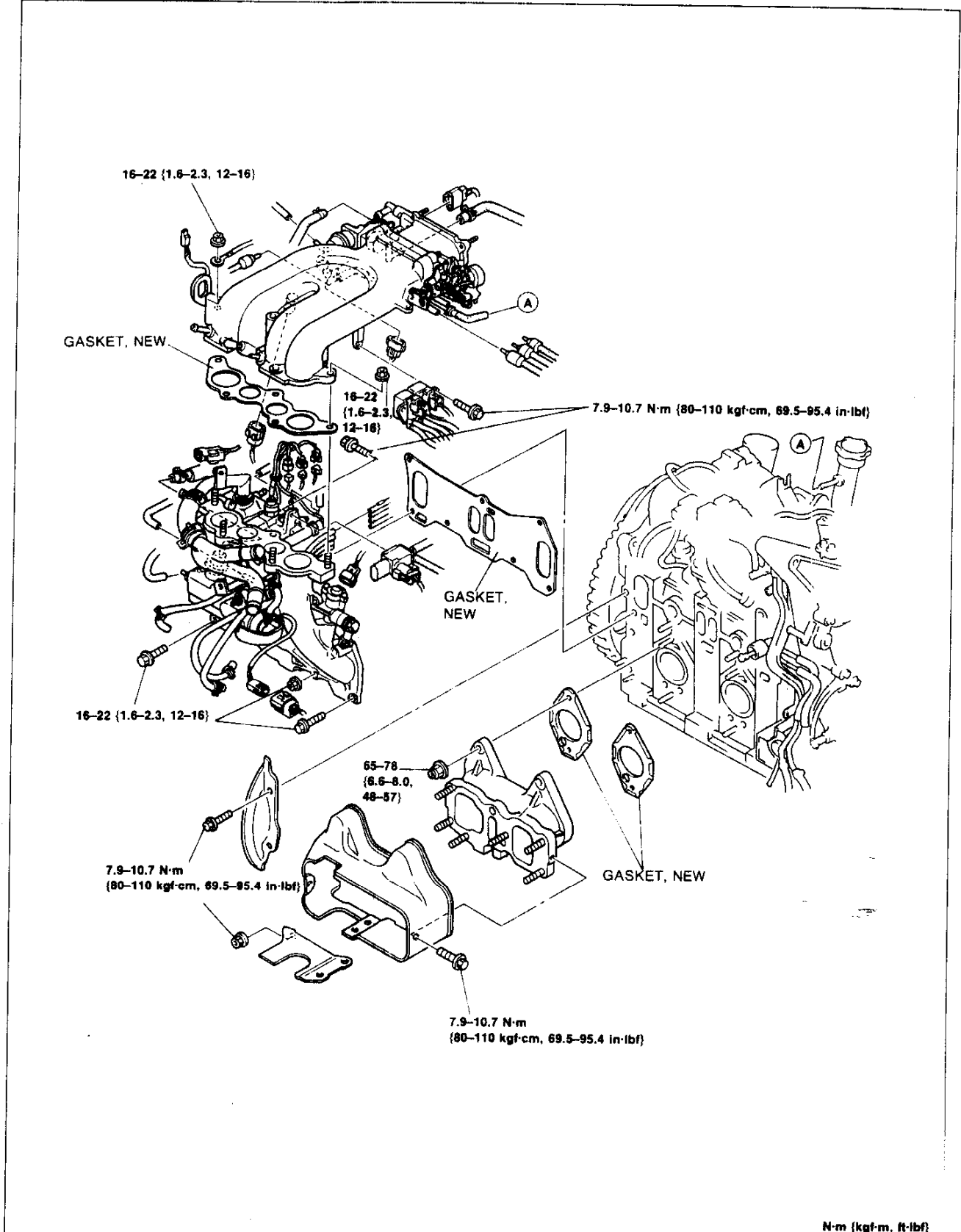

N-m (kgf-m, ft-lbf)

37U0CX-191

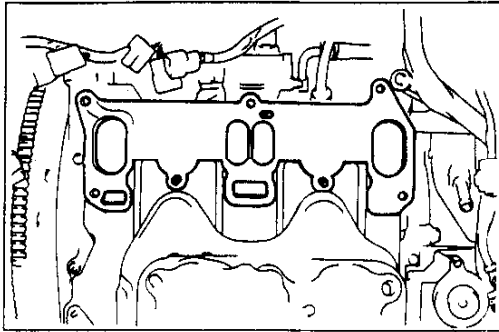

37U0CX-192

Intake manifold assembly

1. Install the new intake manifold gasket on the engine.

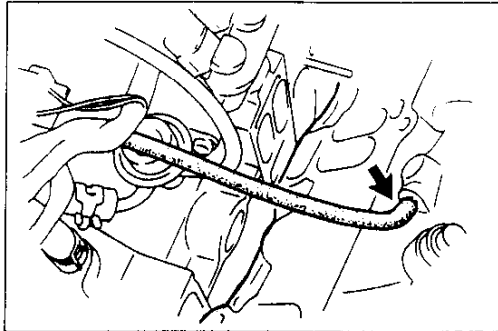

37U0CX-193

2. Connect the vacuum hose to the intake manifold.

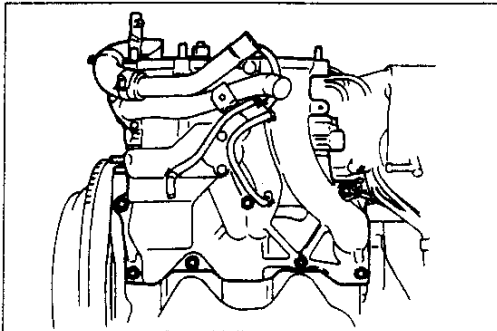

37U0CX-194

3. Install the intake manifold.

Tightening torque:

16–22 N·m {1.6–2.3 kgf·m, 12–16 ft·lbf}

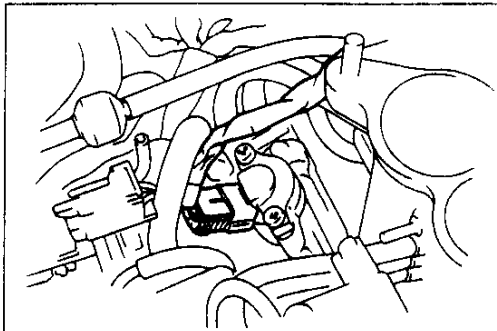

37U0CX-195

4. Connect the injector connectors.

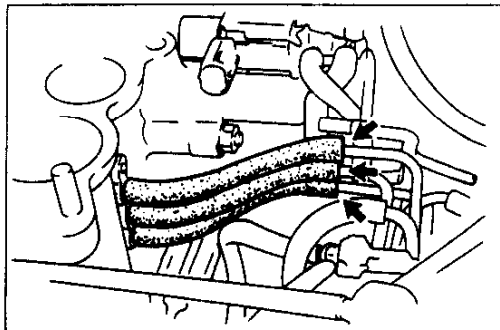

37U0CX-196

5. Connect the vacuum hoses as shown in the figure.

C

ASSEMBLY

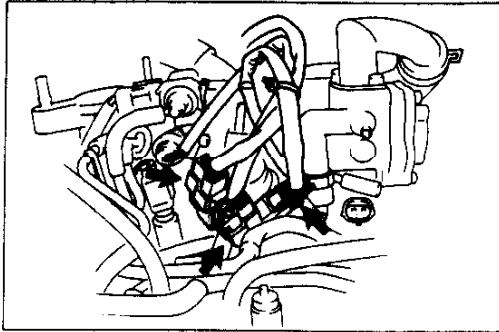

37U0CX-197

6. Connect the connectors shown in the figure.

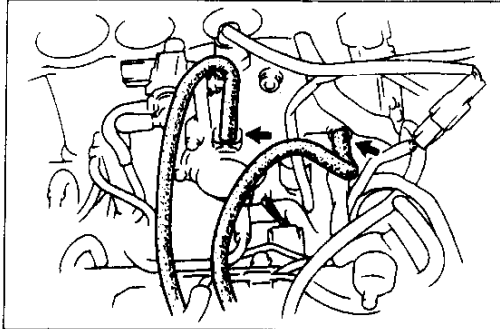

37U0CX-198

7. Connect the vacuum hoses as shown in the figure.

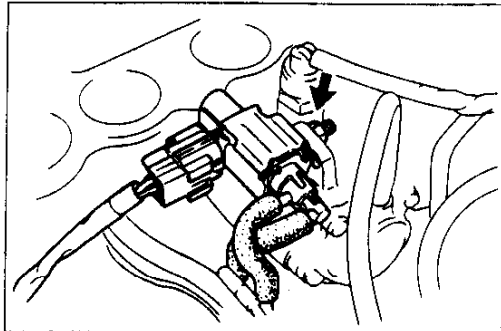

37U0CX-199

8. Install the three-way solenoid shown in the figure.

Tightening torque:

7.9–10.7 N·m {80–110 kgf·cm, 69.5–95.4 in·lbf}

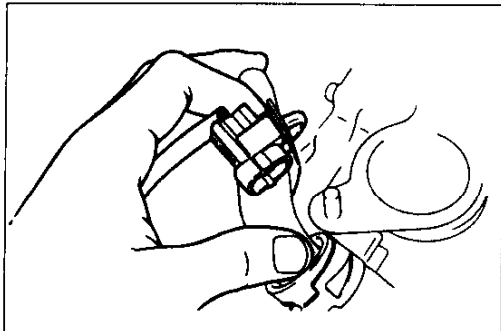

37U0CX-200

9. Mount the oxygen sensor connector.

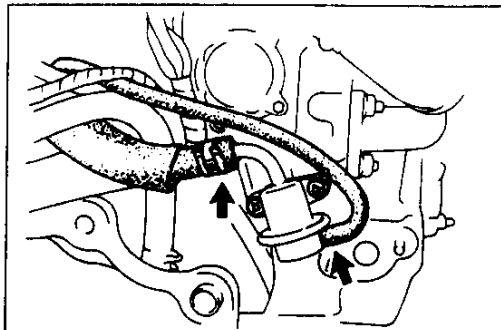

37U0CX-201

10. Connect the fuel hose and vacuum hose.

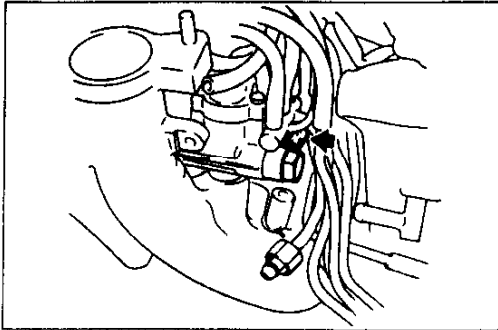

37U0CX-202

11. Connect the fuel hose shown in the figure.

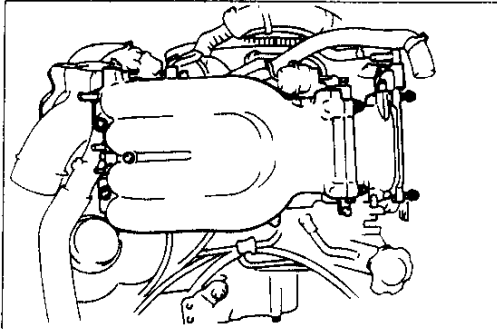

37U0CX-203

Surge tank assembly

1. Install the surge tank assembly and the ground harness.

Tightening torque:

16–22 N·m {1.6–2.3 kgf·m, 12–16 ft·lbf}

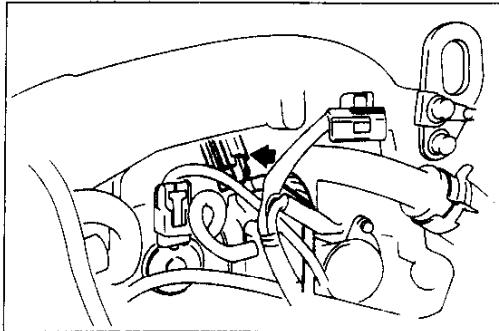

37U0CX-204

2. Connect the connector shown in the figure.

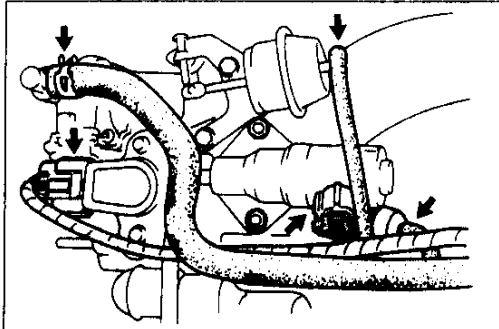

37U0CX-205

3. Connect the connector and the hoses shown in the figure.

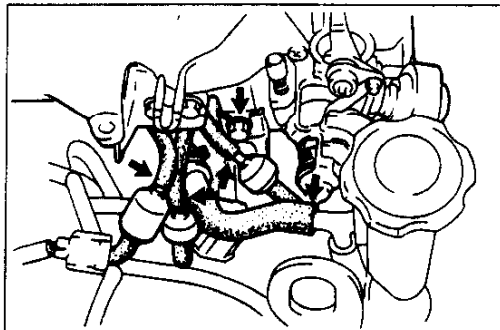

37U0CX-206

4. Tighten the bolt.

Tightening torque:

19–25 N·m {1.9–2.6 kgf·m, 14–18 ft·lbf}

5. Connect the vacuum hoses and the blowby hose as shown in the figure.

C

ASSEMBLY

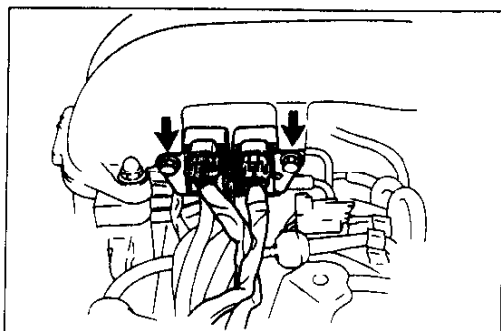

37U0CX-207

6. Connect the duty solenoid valve as shown in the figure.

Tightening torque:

7.9–10.7 N·m {80–110 kgf·cm, 69.5–95.4 in·lbf}

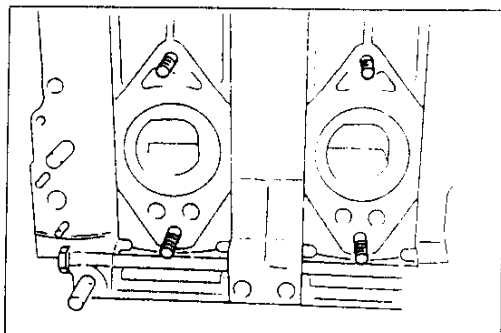

37U0CX-208

Exhaust manifold

1. Retighten the studs to the specified torque.

Tightening torque:

30–35 N·m {3.0–3.6 kgf·m, 22–26 ft·lbf}

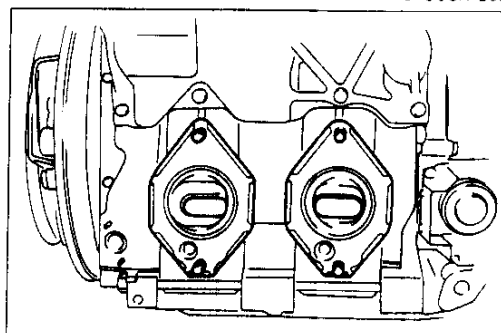

37U0CX-209

2. Install the new exhaust manifold gaskets on the engine.

Caution

- Install the gaskets with the crimped side facing the exhaust manifold.

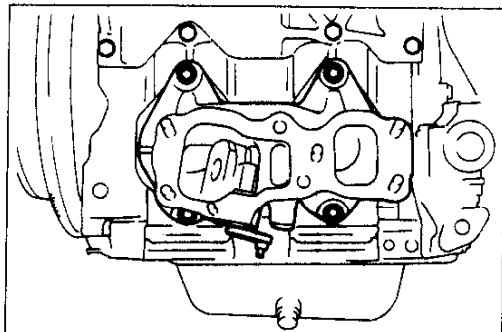

37U0CX-210

3. Install the exhaust manifold.

Tightening torque:

65–78 N·m {6.6–8.0 kgf·m, 48–57 ft·lbf}

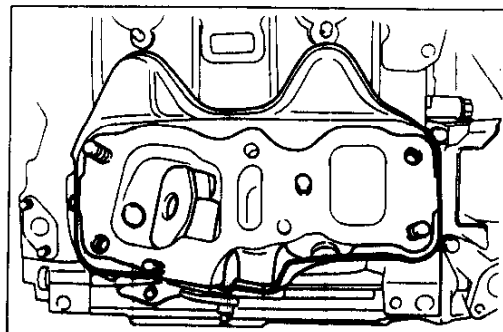

37U0CX-211

Exhaust manifold insulator

1. Install the exhaust manifold insulator.

Tightening torque:

7.9–10.7 N·m {80–110 kgf·cm, 69.5–95.4 in·lbf}

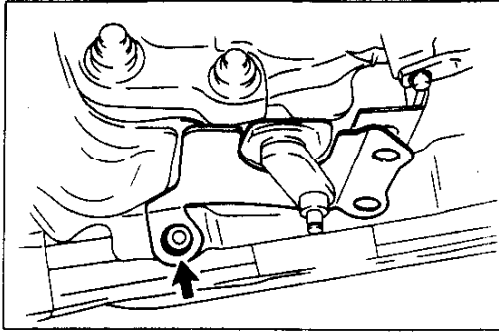

37U0CX-212

2. Install the exhaust manifold insulator.

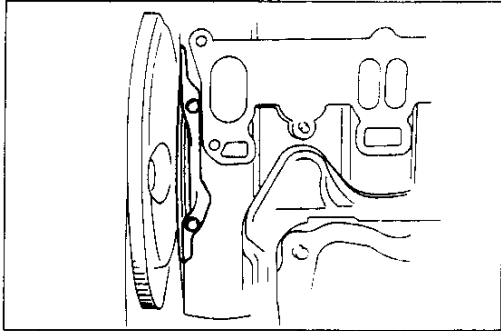
Tightening torque:**7.9–10.7 N·m {80–110 kgf·cm, 69.5–95.4 in·lbf}**

37U0CX-213

Oil seal plate

Install the oil seal plate.

Tightening torque:**7.9–10.7 N·m {80–110 kgf·cm, 69.5–95.4 in·lbf}**

TURBOCHARGER

Torque specifications

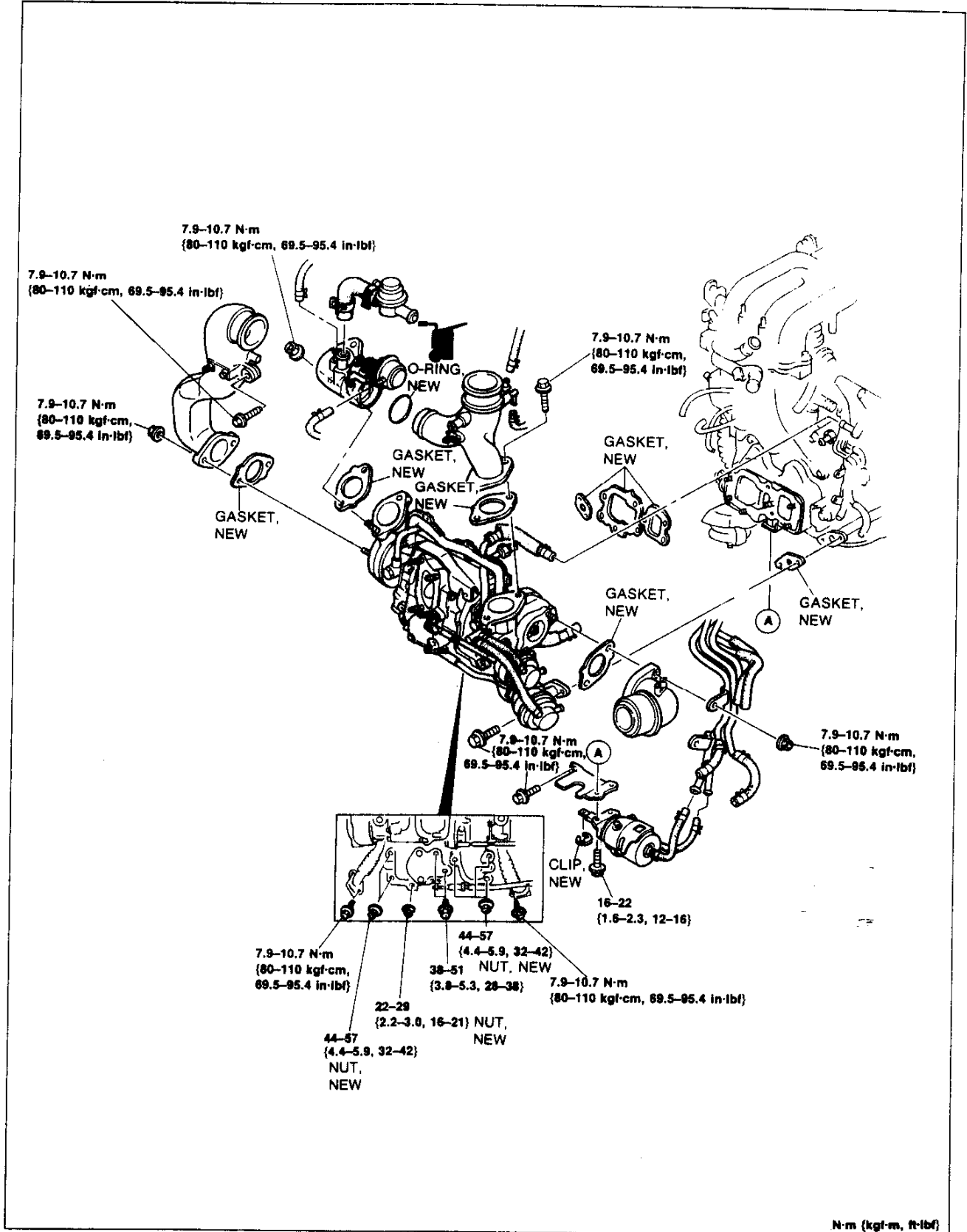

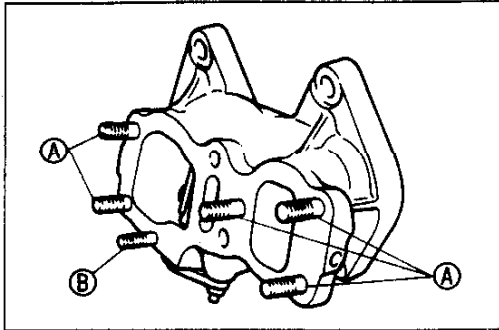

37U0CX-215

Turbocharger

1. Retighten the stud to the specified torque.

Tightening torque:

A: 16–23 N·m {1.6–2.4 kgf·m, 12–17 ft·lbf}

B: 7.9–11.7 N·m {80–120 kgf·cm, 70–104 in·lbf}

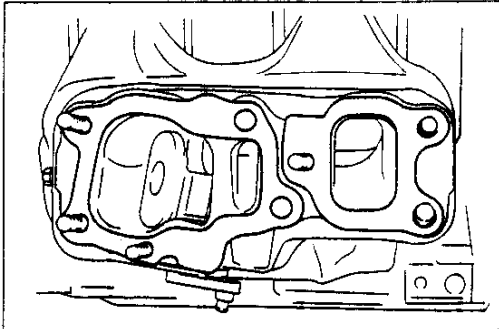

37U0CX-216

2. Install the new turbocharger gaskets.

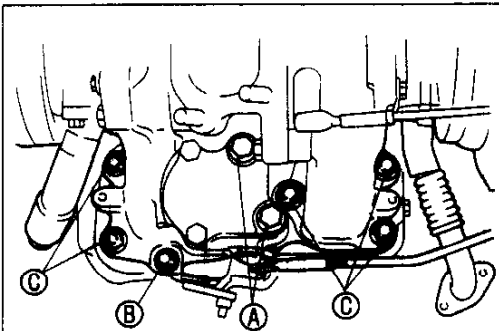

37U0CX-217

3. Install the turbocharger assembly.

Tightening torque:

A: 38–51 N·m {3.8–5.3 kgf·m, 28–38 ft·lbf}

B: 22–29 N·m {2.2–3.0 kgf·m, 16–21 ft·lbf}

C: 44–57 N·m {4.4–5.9 kgf·m, 32–42 ft·lbf}

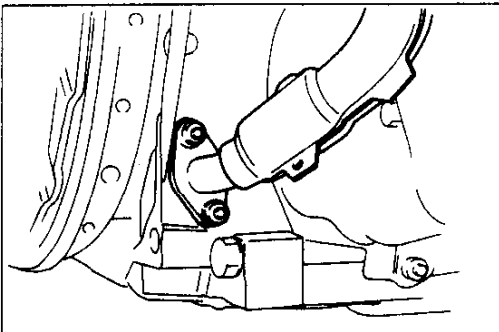

37U0CX-218

4. Connect the oil outlet pipe along with a new gasket.

Tightening torque:

7.9–10.7 N·m {80–110 kgf·cm, 69.5–95.4 in·lbf}

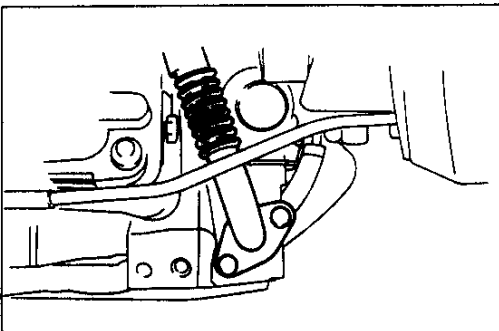

37U0CX-219

5. Connect the oil outlet pipe along with a new gasket.

Tightening torque:

7.9–10.7 N·m {80–110 kgf·cm, 69.5–95.4 in·lbf}

C

ASSEMBLY

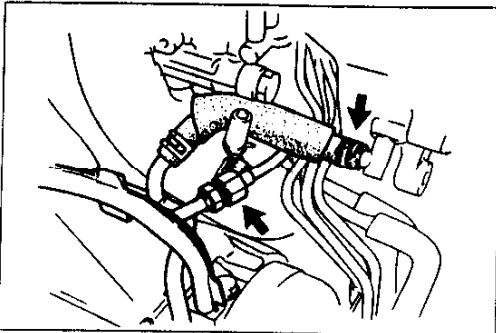

37U0CX-220

6. Connect the oil inlet pipe and water hose.

Caution

- Do not twist the oil inlet pipe.

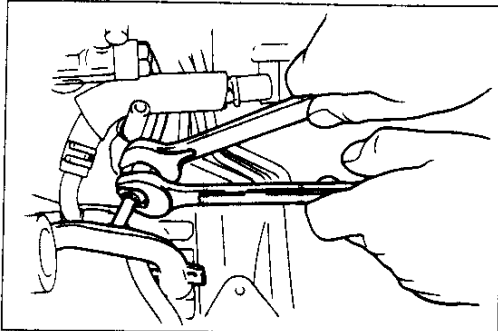

37U0CX-221

7. Tighten the oil inlet pipe connector bolt.

Caution

- Use two wrenches, as shown.

Tightening torque:

18–22 N·m {1.8–2.3 kgf·m, 14–16 ft·lbf}

8. Tighten the oil inlet pipe connecting bolt. (Refer to C-80)

Tightening torque

24–35 N·m {2.4–3.6 kgf·m, 18–26 ft·lbf}

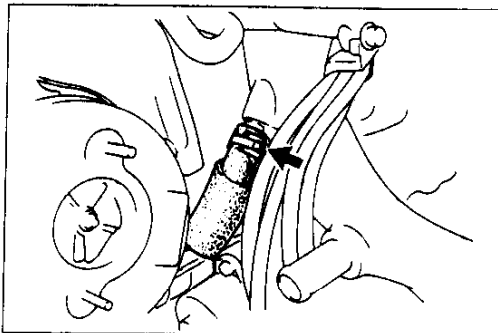

37U0CX-212

9. Connect the water hose.

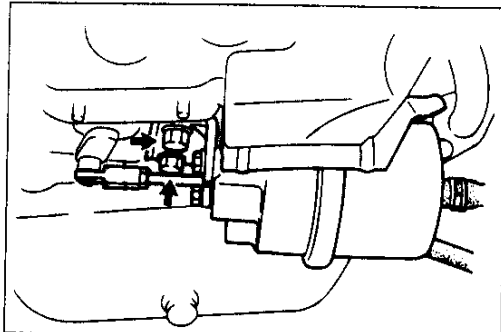

37U0CX-223

10. Install the turbo control actuator.

Tightening torque:

16–22 N·m {1.6–2.3 kgf·m, 12–16 ft·lbf}

11. Connect the air hoses.

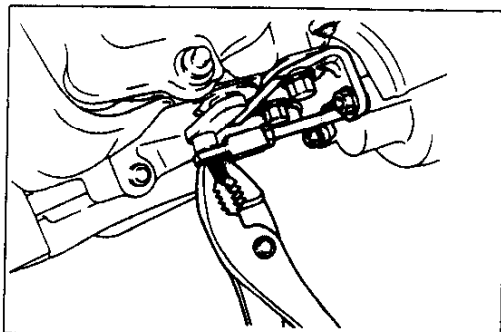

37U0CX-224

12. Install a new clip on the actuator rod.

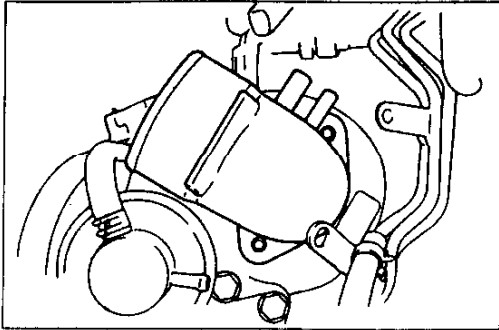

37U0CX-225

Air intake pipe

Install the air intake pipe.

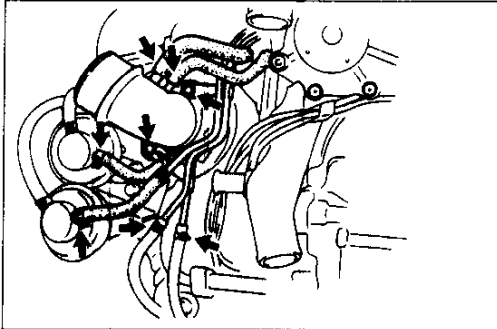

37U0CX-226

Vacuum pipe

1. Install the vacuum pipe.

Tightening torque:

7.9–10.7 N·m {80–110 kgf·cm, 69.5–95.4 in·lbf}

2. Connect the vacuum hoses.

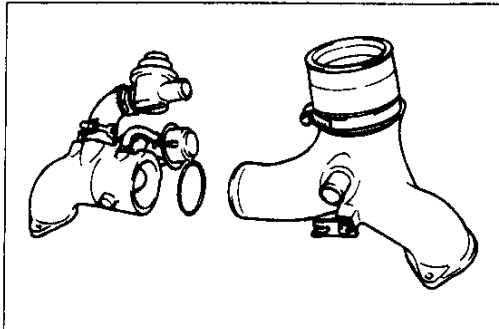

37U0CX-227

Air pipe and control valve

1. Apply clean engine oil to the new O-ring, and install it between the air pipe and control valve.

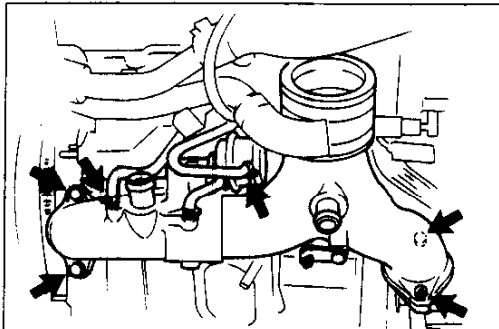

37U0CX-228

2. Install the air pipe and control valve on the turbocharger assembly along with new gaskets.

Tightening torque:

7.9–10.7 N·m {80–110 kgf·cm, 69.5–95.4 in·lbf}

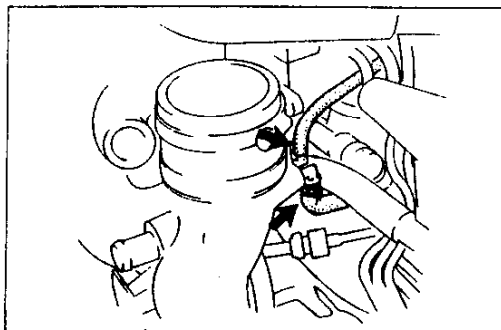

37U0CX-229

3. Connect the vacuum hoses shown in the figures.

C

ASSEMBLY

4. Connect the hoses shown in the figure.

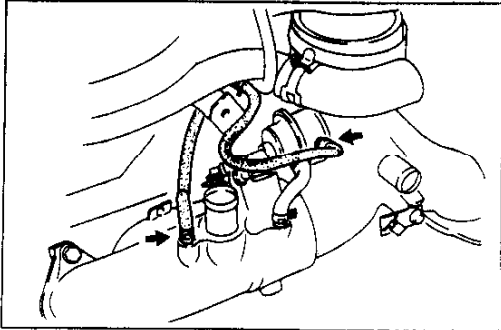

37U0CX-230

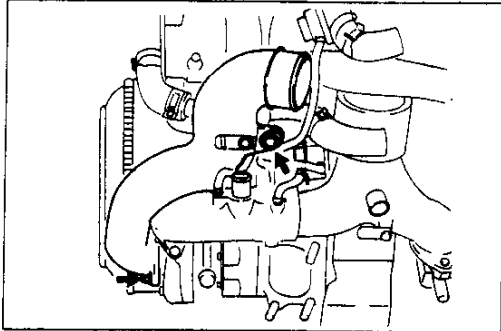

37U0CX-231

Air pipe

Install the air pipe along with a new gasket.

Tightening torque:

7.9–10.7 N·m {80–110 kgf·cm, 69.5–95.4 in·lbf}

AUXILIARY PARTS (I)
Torque specifications

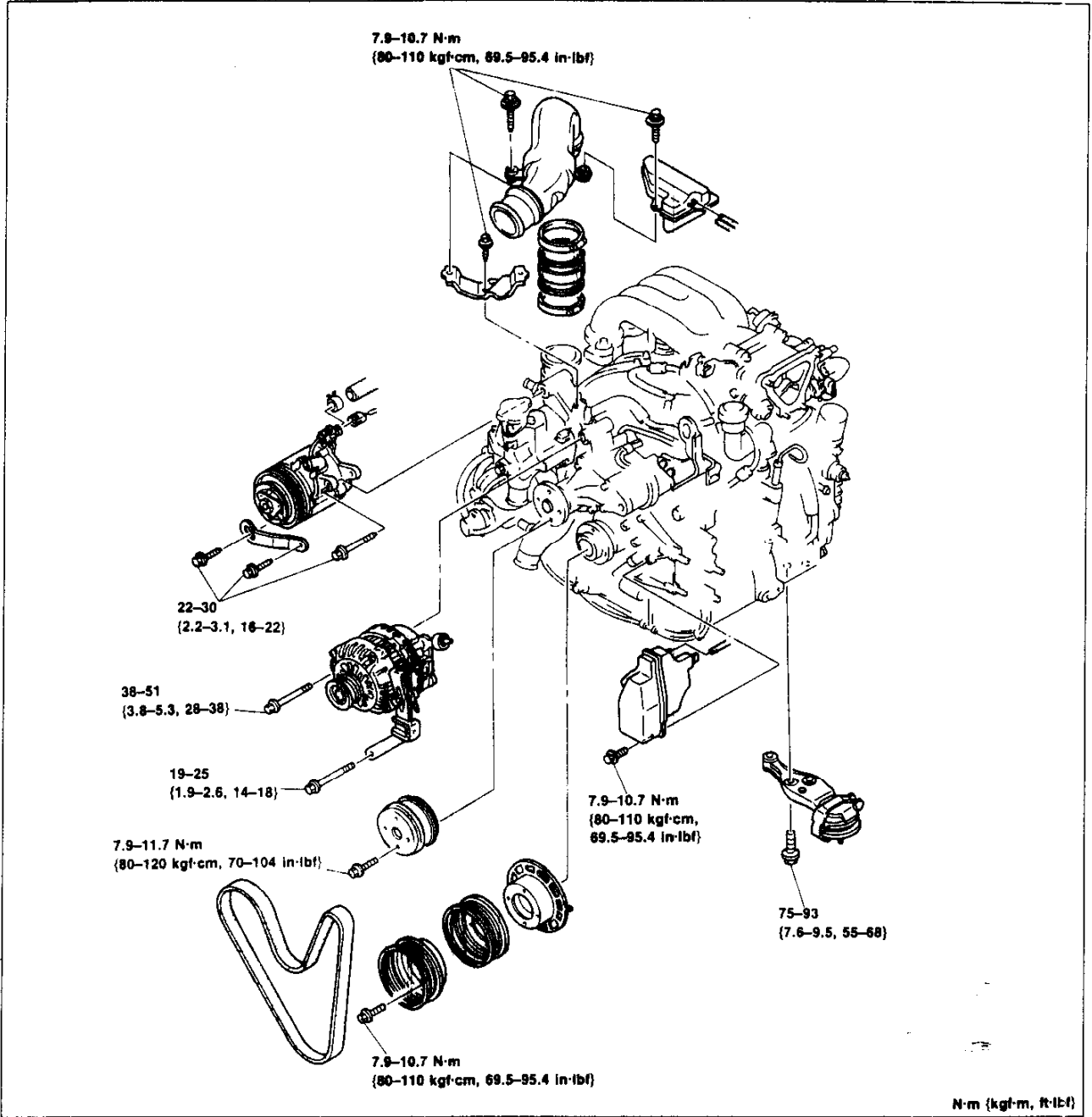

37U0CX-132

C

ASSEMBLY

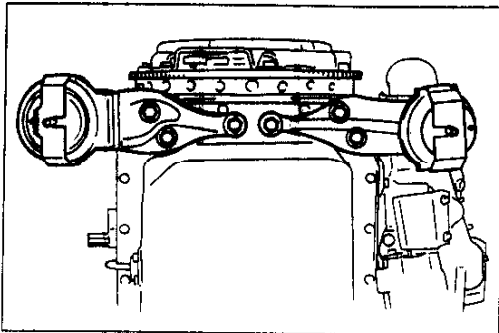

37U0CX-233

Engine mount right and left.

Install the engine mount right and left.

Tightening torque:

75–93 N·m {7.6–9.5 kgf·m, 55–68 ft·lbf}

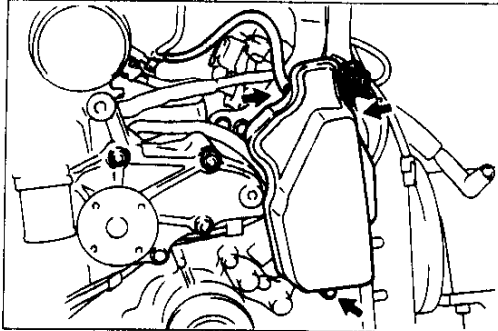

37U0CX-234

Vacuum chamber

1. Connect the vacuum hose.
2. Install the vacuum chamber.

Tightening torque:

7.9–10.7 N·m {80–110 kgf·cm, 69.5–95.4 in·lbf}

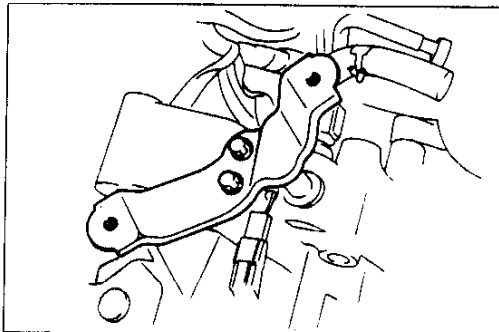

37U0CX-235

Air pipe and bracket

1. Install the air pipe bracket.

Tightening torque:

7.9–10.7 N·m {80–110 kgf·cm, 69.5–95.4 in·lbf}

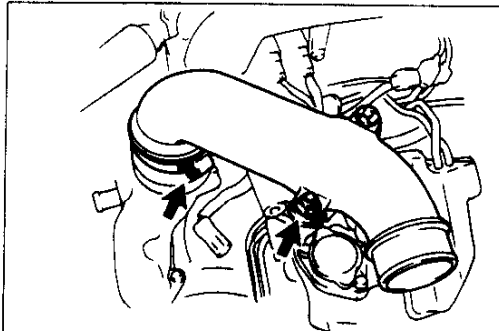

37U0CX-236

2. Install the air pipe.

Tightening torque:

7.9–10.7 N·m {80–110 kgf·cm, 69.5–95.4 in·lbf}

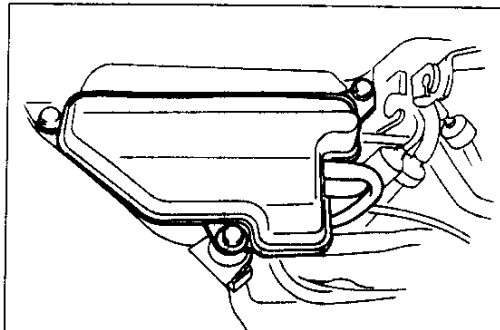

37U0CX-237

3. Install the pressure chamber.

Tightening torque:

7.9–10.7 N·m {80–110 kgf·cm, 69.5–95.4 in·lbf}

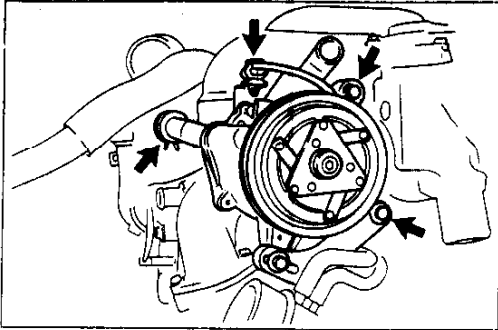

37U0CX-238

Air pump

1. Install the air pump and bracket and loosely tighten the mounting bolts.
2. Connect the connector and air hose

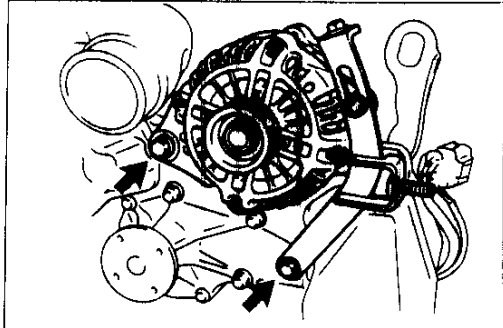

37U0CX-239

Alternator and bracket

Install the alternator and bracket and loosely tighten the mounting bolts.

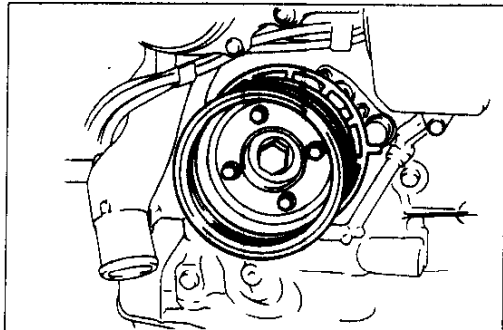

37U0CX-240

Drive belt pulley

Install the drive belt pulley as shown in the figure.

Tightening torque:

7.9–10.7 N·m {80–110 kgf·cm, 69.5–95.4 in·lbf}

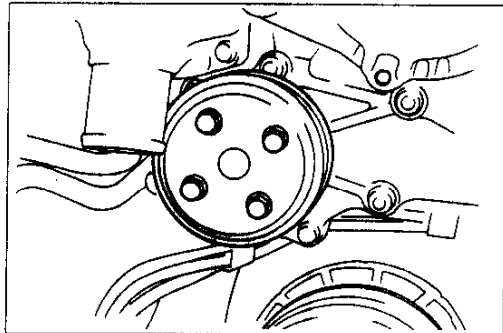

37U0CX-241

Water pump pulley

1. Install the water pump pulley and loosely tighten the mounting bolts.
2. Install the drive belt. (Refer to page C-5.)
3. Tighten the water pump pulley bolts to specified torque.

Tightening torque:

7.9–11.7 N·m {80–120 kgf·cm, 70–104 in·lbf}

ENGINE STAND DISMOUNTING**PROCEDURE**

1. Remove the engine from the engine stand.
2. Remove the **SST** from the engine.

37U0CX-42

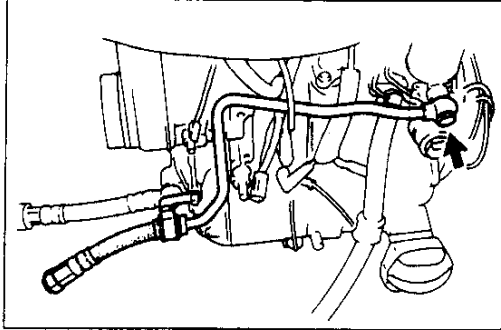

37U0CX-243

3. Install the new studs into the front housing.
4. Install new washers and the oil pipe.

Tightening torque:**54–68 N·m {5.5–7.0 kgf·m, 40–50 ft·lbf}**

INSTALLATION

PREPARATION SST

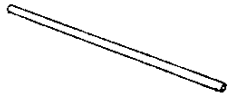
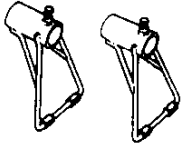
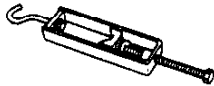
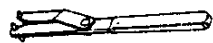
<p>49 G017 5A0 Support, engine</p> 	<p>For support of engine</p>	<p>49 G017 501 Bar (Part of 49 G017 5A0)</p> 	<p>For support of engine</p>
<p>49 G017 502 Support (Part of 49 G017 5A0)</p> 	<p>For support of engine</p>	<p>49 G017 503 Hook (Part of 49 G017 5A0)</p> 	<p>For support of engine</p>
<p>49 W023 585A Adjust wrench</p> 	<p>For removal / installation of locknut</p>	<p>37U0CX-244</p>	

C

INSTALLATION

PROCEDURE

Step 1

Warning

- Be sure the vehicle is securely supported on safety stands.

Torque specifications

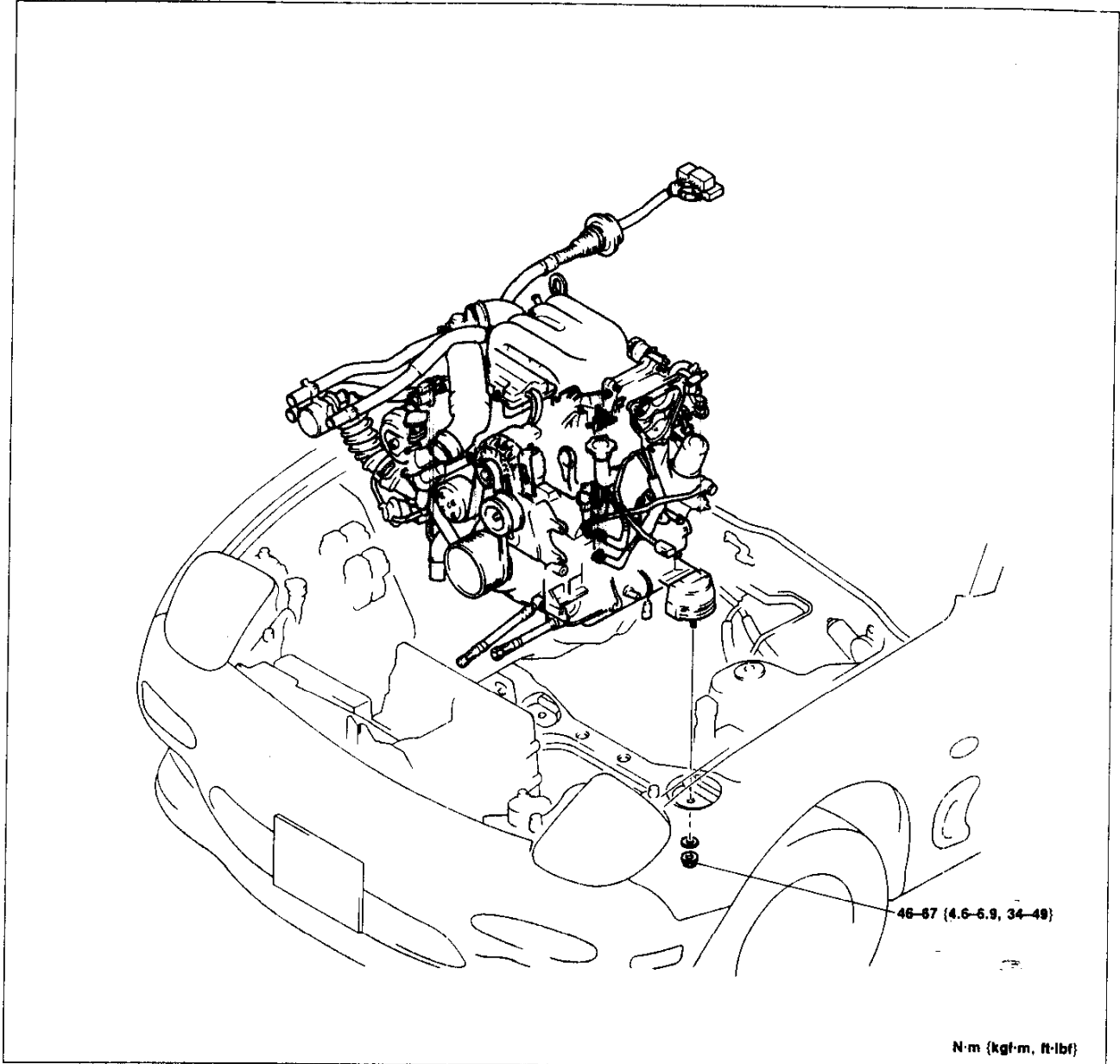

37U0CX-245

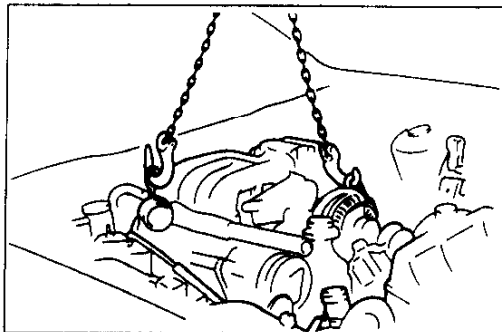

37U0CX-246

Engine

1. Suspend the engine.

Caution

- Do not damage any components in the engine compartment.
2. Install the engine in the engine compartment, aligning the engine mounts with the crossmember mounting holes.

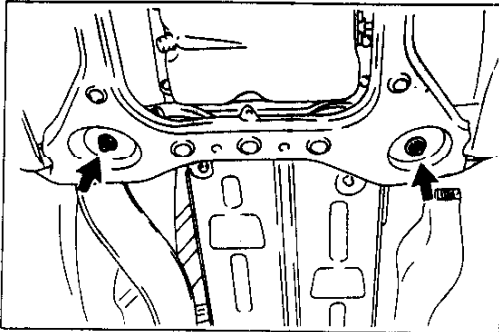

Engine mount

Install and tighten the engine mount nuts.

Tightening torque:

46-67 N·m {4.6-6.9 kgf·m, 34-49 ft·lb}

Step 2

37U0CX-247

Torque specifications

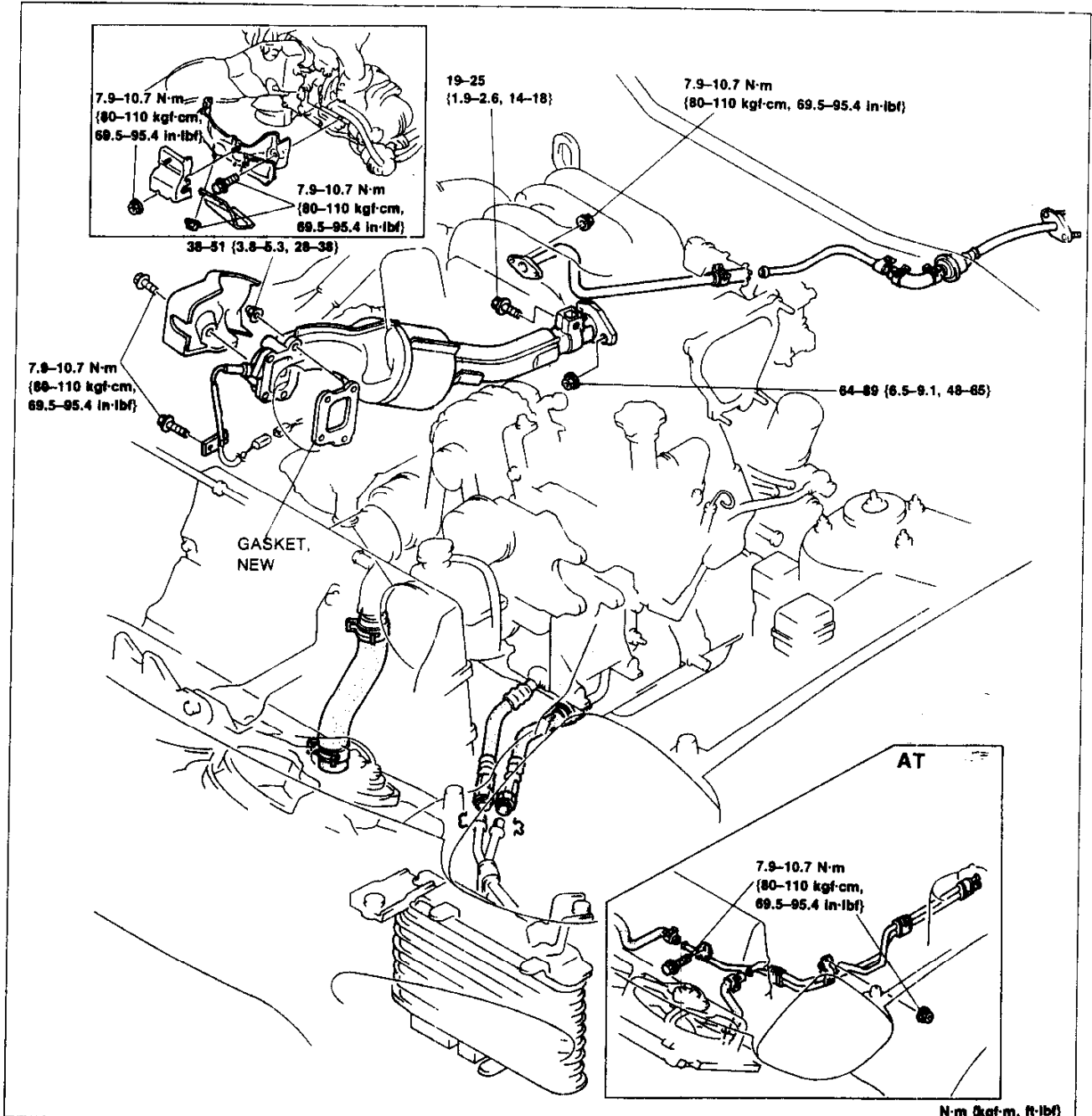

N·m (kgf·m, ft·lb)

37U0CX-298

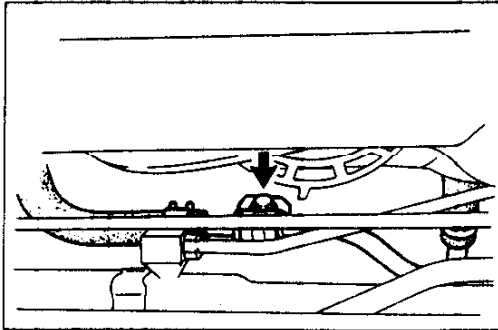

37UOCX-249

Oil Cooler Pipe (AT)

1. Install the oil cooler pipe.
2. Tighten the bolt.

Tightening torque:

7.9–10.7 N·m {80–110 kgf·cm, 69.5–95.4 in·lbf}

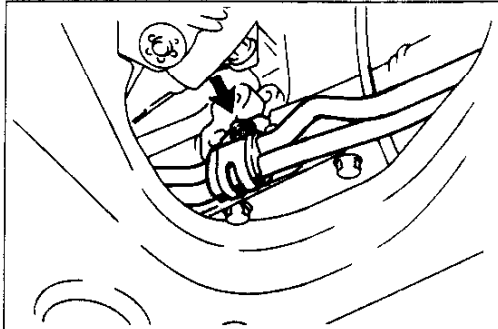

37UOCX-250

3. Tighten the nut shown in the figure.

Tightening torque:

7.9–10.7 N·m {80–110 kgf·cm, 69.5–95.4 in·lbf}

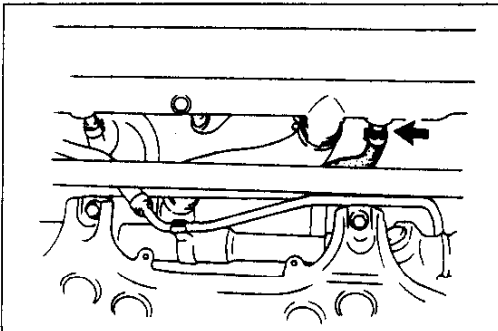

37UOCX-251

4. Connect the oil cooler hose.

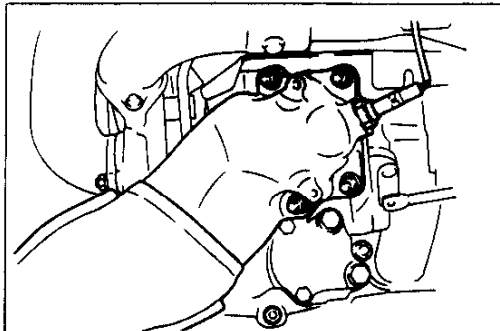

37UOCX-252

Front Exhaust Pipe

1. Connect the front exhaust pipe along with a new gasket.

Tightening torque:

38–51 N·m {3.8–5.3 kgf·m, 28–38 ft·lbf}

2. Install the oxygen sensor harness.

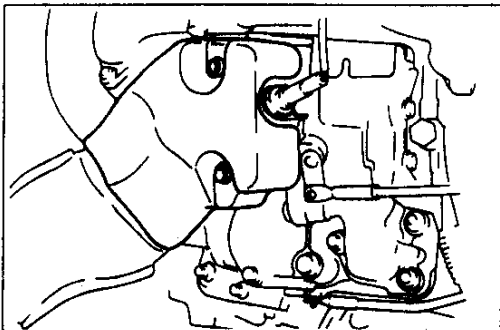

37UOCX-253

Insulator

1. Install the front exhaust pipe insulator and loosely tighten the bolts.

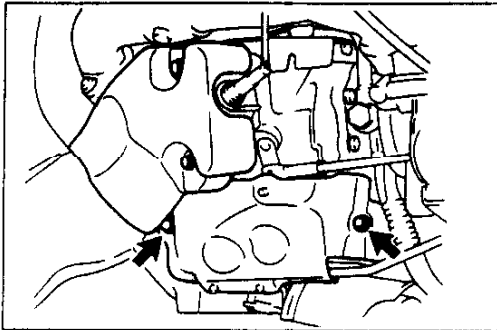

37U0CX-254

2. Install the turbo insulator and loosely tighten the bolts.

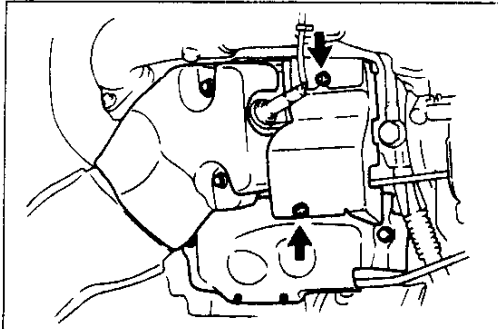

37U0CX-255

3. Install the center insulator and loosely tighten the bolts.

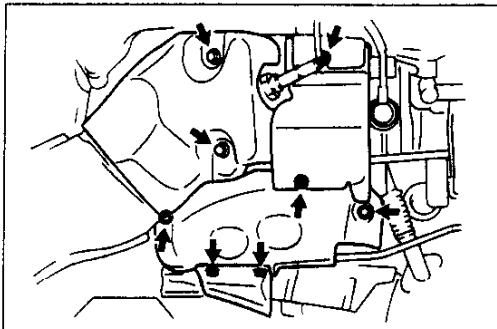

37U0CX-256

4. Tighten the insulator fasteners.

Tightening torque:

7.9–10.7 N·m {80–110 kgf·cm, 69.5–95.4 in·lbf}

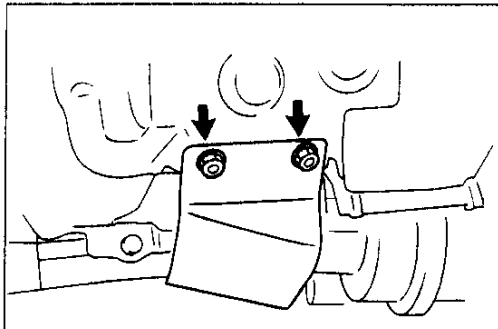

37U0CX-257

5. Install the insulator.

Tightening torque:

7.9–10.7 N·m {80–110 kgf·cm, 69.5–95.4 in·lbf}

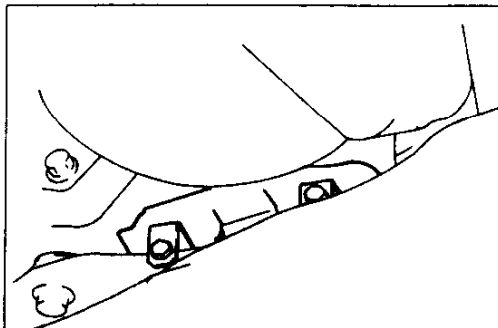

37U0CX-258

6. Install the engine mount insulator.

Tightening torque:

7.9–10.7 N·m {80–110 kgf·cm, 69.5–95.4 in·lbf}

C

INSTALLATION

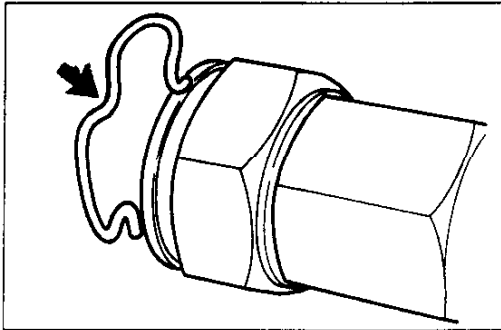

37U0CX-259

Oil Pipe

Connect the oil pipe and install the retaining clip.

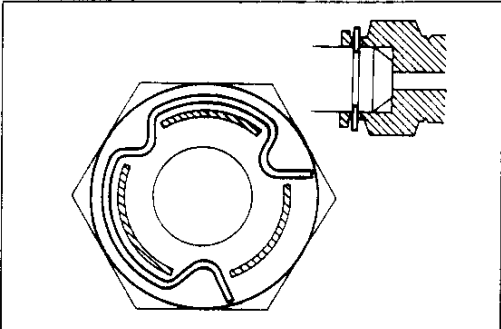

37U0CX-260

Caution

- After connecting the oil pipe, verify that it is securely locked.

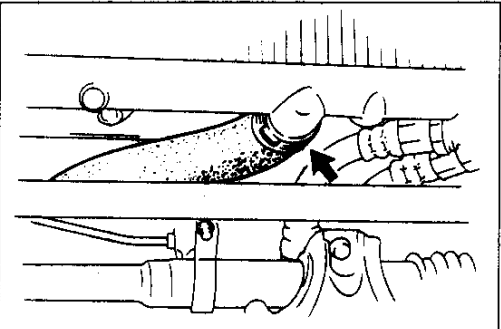

37U0CX-261

Radiator hose (lower)

Connect the lower radiator hose.

Step 3

Connect the harness connectors and the hoses shown in the figure.

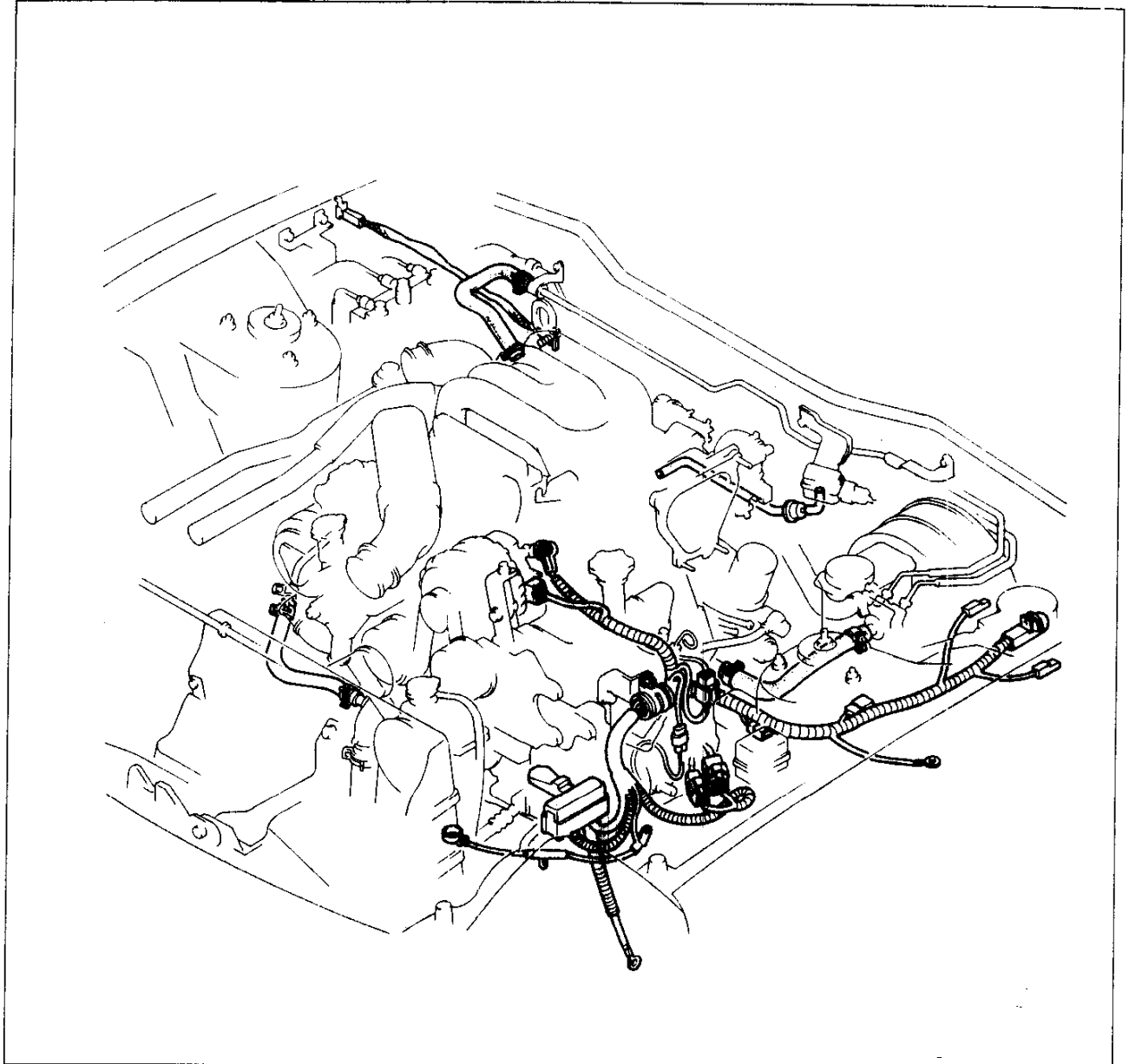

37U0CX-262

C

INSTALLATION

Step 4

Torque specifications

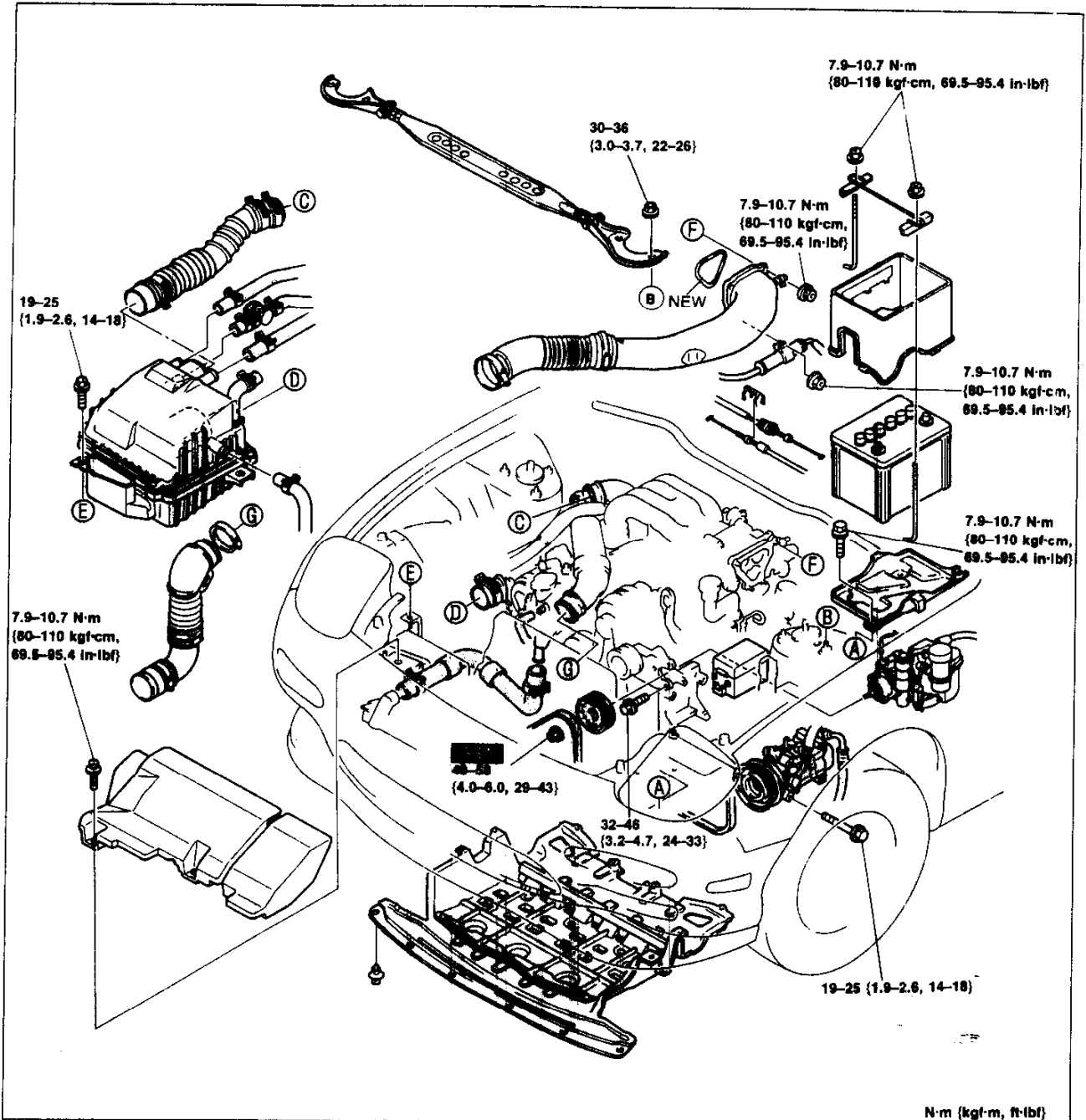

37UOCX-233

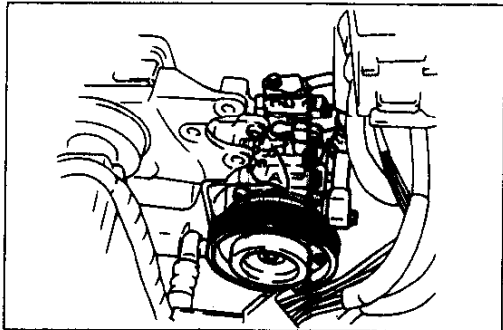

A/C compressor

Install the A/C compressor to the bracket.

Tightening torque:

19-25 N·m {1.9-2.6 kgf·m, 14-18 ft·lbf}

37UOCX-264

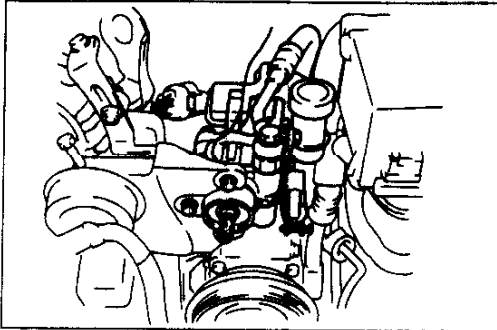

37UOCX-265

P/S oil pump

1. Install the P/S oil pump to the bracket.

Tightening torque:

32-46 N·m {3.2-4.7 kgf·m, 24-33 ft·lbf}

2. Connect the connector.

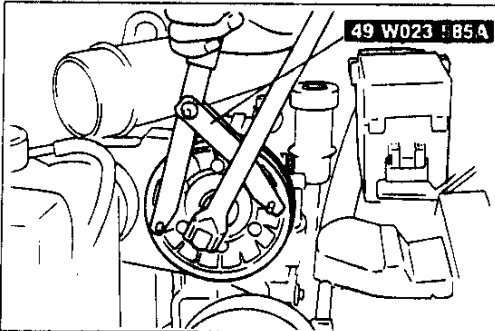

37UOCX-266

P/S oil pump pulley

1. Install the P/S oil pump pulley to the pump body and loosely tighten the nut.
2. Tighten the pulley nut while holding the pulley with the SST.

Tightening torque:

40-58 N·m {4.0-6.0 kgf·m, 29-43 ft·lbf}

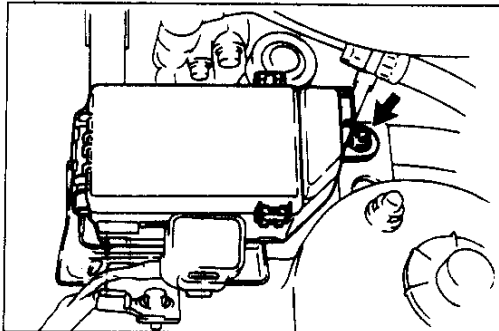

37UOCX-267

Fuse box

Install the fuse box.

Tightening torque:

7.9-10.7 N·m {80-110 kgf·cm, 69.5-95.4 in·lbf}

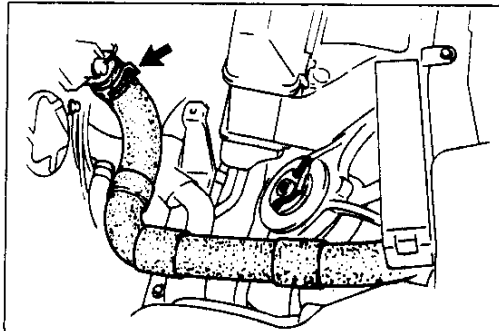

37UOCX-268

Radiator hose (upper)

Connect the upper radiator hose.

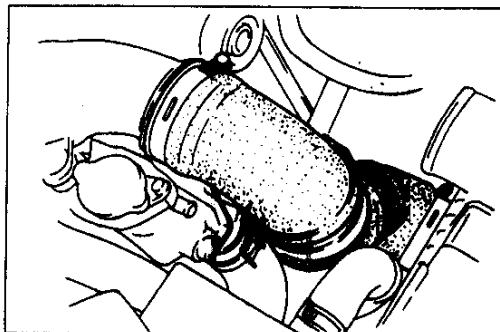

37UOCX-269

Air hose

Connect the air hose.

C

INSTALLATION

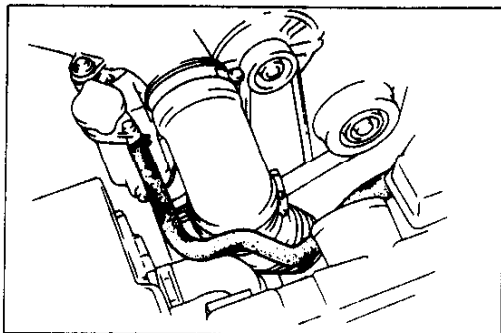

37U0CX-270

Water hose

Connect the water hose.

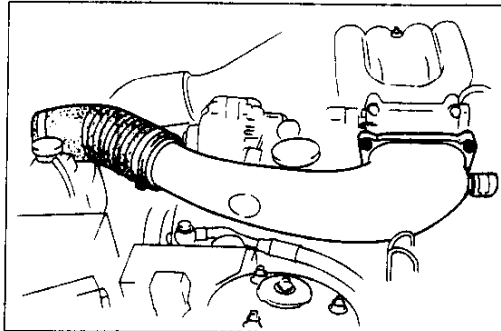

37U0CX-271

Hose

Install the hose.

Tightening torque:

7.9–10.7 N·m {80–110 kgf·cm, 69.5–95.4 in·lbf}

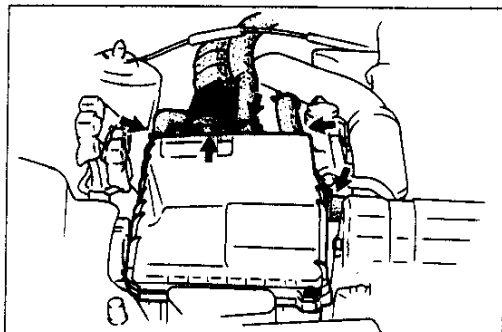

37U0CX-272

Air cleaner assembly

1. Connect the air hose.
2. Install the air cleaner assembly.

Tightening torque:

7.9–10.7 N·m {80–110 kgf·cm, 69.5–95.4 in·lbf}

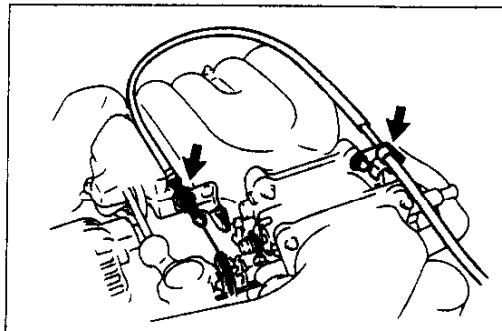

37U0CX-273

Accelerator cable

1. Install the accelerator cable.
2. Adjust the cable deflection.

Deflection:

1–3 mm {0.04–0.12 in}

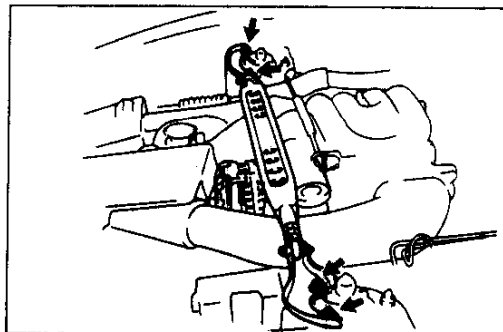

37U0CX-274

Strut bar

1. Remove the upper nuts.
2. Install the strut bar.

Tightening torque:

30–36 N·m {3.0–3.7 kgf·m, 22–26 ft·lbf}

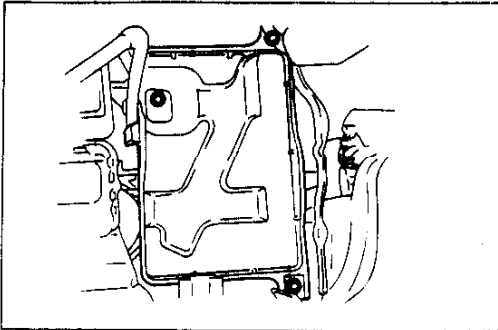

37UOCX-275

Battery and carrier

1. Install the battery carrier.

Tightening torque:

7.9–10.7 N·m {80–110 kgf·cm, 69.5–95.4 in·lbf}

2. Install the battery.
3. Connect the positive battery cable.

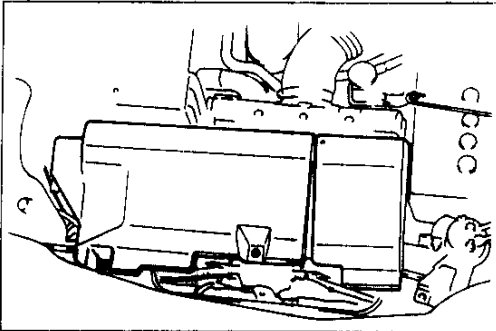

37UOCX-276

Fresh air duct

Install the fresh air duct.

Tightening torque:

7.9–10.7 N·m {80–110 kgf·cm, 69.5–95.4 in·lbf}

Steps After Installation

1. Connect the engine control unit. (Refer to Section F.)
2. Fill the radiator with the specified amount and type of engine coolant. (Refer to Section E.)
3. Fill the engine with the specified amount and type of engine oil. (Refer to Section D.)
4. Connect the negative battery cable.
5. Install the hood.
6. Start the engine and check the following.
 - (1) Engine oil, transmission oil, and engine coolant leakage.
 - (2) Drive belt deflection. (Refer to page C-5.)
 - (3) Ignition timing and idle speed. (Refer to Section F.)
 - (4) Operation of emission control system.
7. Perform a road test.
8. Recheck the engine oil and coolant levels.

37UOCX 277

