

Before beginning any service procedure, refer to the 1993 RX-7 Body Electrical Troubleshooting Manual; see Section S for air bag system precautions and Section J1 for audio antitheft system precautions.

COOLING SYSTEM

INDEX	E - 2
OUTLINE	E - 3
SPECIFICATIONS	E - 3
TROUBLESHOOTING GUIDE	E - 3
ENGINE COOLANT	E - 4
PREPARATION	E - 4
INSPECTION	E - 4
REPLACEMENT	E - 5
AIR BLEEDING	E - 6
RADIATOR CAP	E - 7
PREPARATION	E - 7
INSPECTION	E - 7
RADIATOR AND ELECTRIC	
COOLING FAN	E - 8
REMOVAL / INSTALLATION	E - 8
INSPECTION	E -10
REPLACEMENT	E -12
FAN RELAY	E -13
REMOVAL / INSTALLATION	E -13
INSPECTION	E -13
THERMOSTAT	E -14
REMOVAL / INSTALLATION	E -14
INSPECTION	E -15
WATER PUMP AND WATER	
THERMOSWITCH	E -15
REMOVAL / INSTALLATION	E -15
INSPECTION	E -17

INDEX

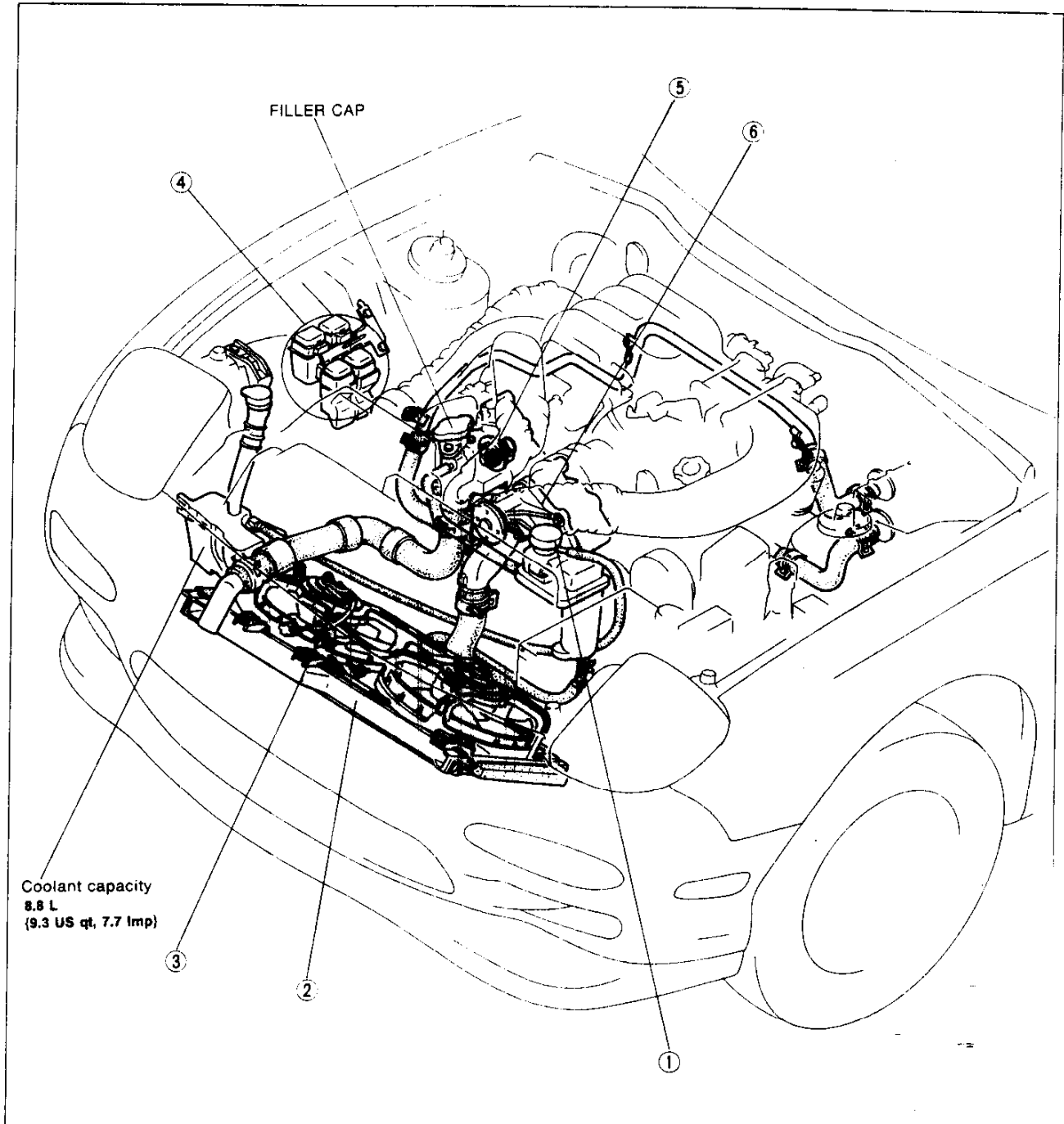

37U0EX-002

1. Radiator cap	
Inspection	page E- 7
2. Radiator	
Removal / Installation	page E- 8
Inspection	page E-10
3. Fan motor	
Inspection	page E-11
Replacement	page E-12

4. Fan relay	
Removal / Installation	page E-13
Inspection	page E-13
5. Thermostat	
Removal / Installation	page E-14
Inspection	page E-15
6. Water pump and water thermostitch	
Removal / Installation	page E-15
Inspection	page E-17

OUTLINE

SPECIFICATIONS

Item		Engine model	13B Turbo
Cooling system			Water-cooled, forced circulation
Coolant capacity		L {US qt, Imp qt}	8.8 {9.3, 7.7}
Water pump	Type		Centrifugal
	Water seal		Unified mechanical seal
Thermostat	Type		Wax, bottom-bypass
	Opening temperature	°C {°F}	80.5-83.5 {177-182}
	Full-open temperature	°C {°F}	95 {203}
	Full-open lift	mm {in}	8-10 {0.31-0.39}
Radiator	Type		Corrugated fin
	Cap valve opening pressure	kPa {kgf/cm ² , psi}	113-142 {1.15-1.45, 16.4-20.6}
Cooling fan	Motor current	A	High: 13.6, Med: 9.5, Low: 8.8
	Number of blades		No.1: 5, No.2: 4
	Outer diameter of blades	mm {in}	No.1, No.2: 300 {11.8}

37U0EX-003

TROUBLESHOOTING GUIDE

Problem	Possible cause	Action	Page
Overheating	Coolant level insufficient	Add	E-5
	Coolant leakage	Repair	-
	Radiator fins clogged	Clean	E-10
	Radiator cap malfunction	Replace	E-7
	Cooling fan malfunction	Replace	E-11
	Thermostat malfunction	Replace	E-15
	Water passage clogged	Clean	E-5
Corrosion	Water pump malfunction	Replace	E-16
	Impurities in coolant	Replace	E-5

37U0EX-004

E

ENGINE COOLANT

ENGINE COOLANT

PREPARATION

SST

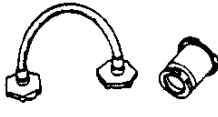
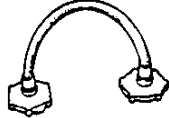
<p>49 9200 145</p> <p>Adapter set, radiator cap tester</p> 	<p>For inspection of cooling system pressure</p>	<p>49 9200 146</p> <p>Adapter A (Part of 49 9200 145)</p> 	<p>For inspection of cooling system pressure</p>
--	--	---	--

05U0EX-005

INSPECTION

Warning

- **Never remove the radiator cap while the engine is hot.**
- **Wrap a thick cloth around the cap when removing it.**
- **When removing the radiator cap, loosen it slowly to the first stop until the pressure in the radiator is released, and then remove it.**

03U0EX-006

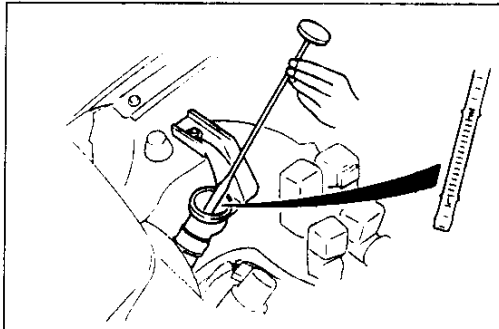

03U0EX-007

Coolant Level (Engine cold)

1. Verify that the coolant level is near the filler neck.
2. Verify that the coolant level in the coolant reservoir is between the F and L.
3. Add coolant if necessary.

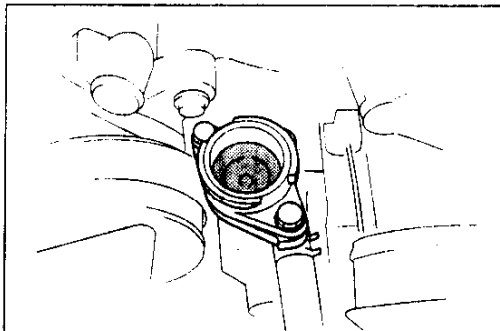

03U0EX-008

Coolant Quality

Warning

- **Never open the radiator cap while the engine is hot.**
- **Wrap a thick cloth around the cap when loosening.**
- **Use caution when draining hot coolant.**

1. Verify that there is no buildup of rust or scale around the radiator cap or filler neck.
2. Verify that coolant is free of oil. Replace the coolant if necessary.

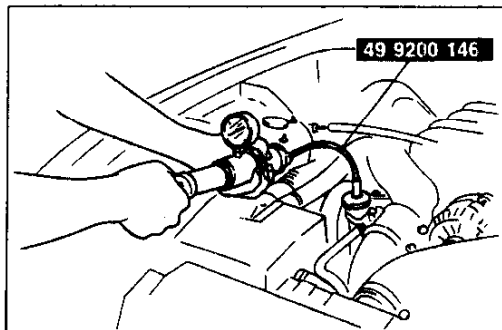

37U0EX-005

Coolant Leakage

1. Connect a radiator tester (commercially available) and the **SST** to the radiator filler neck.
2. Apply **142 kPa {1.45 kgf/cm², 20.6 psi}** of pressure to the system.
3. Verify that the pressure is held.
4. If not as specified, check for coolant leakage.

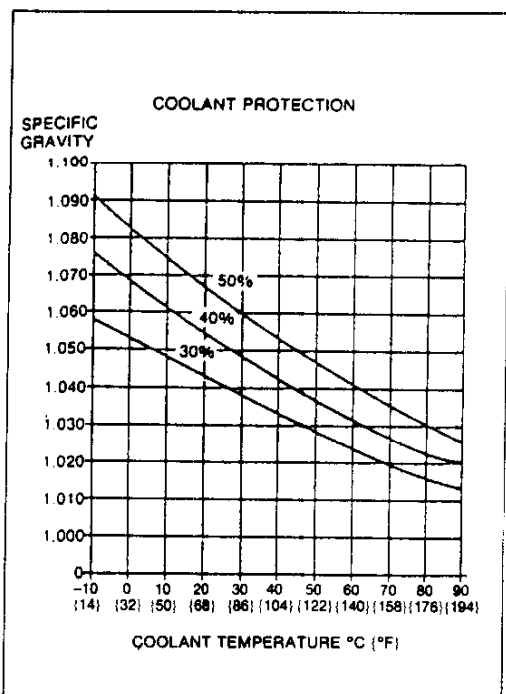

05U0EX-009

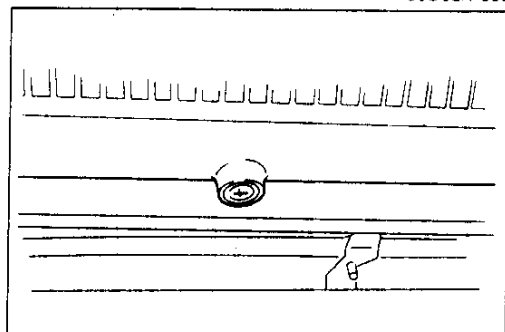

37U0EX-005

Coolant Protection

Caution

- Do not use alcohol- or methanol-based coolant.
- Use only soft (demineralized) water in the coolant mixture.

1. Measure the coolant temperature and the specific gravity with a thermometer and a hydrometer.
2. Determine the coolant protection by referring to the graph shown.
3. If the coolant protection is not proper, add water or coolant.

Antifreeze solution mixture percentage

Coolant protection	Volume percentage		Gravity at 20°C (68°F)
	Water	Coolant	
Above - 16°C (3°F)	65	35	1.054
Above - 26°C (15°F)	55	45	1.066
Above - 40°C (40°F)	45	55	1.078

05U0EX-110

REPLACEMENT

Warning

- Never open the radiator cap while the engine is hot.
- Wrap a thick cloth around the cap when loosening.
- Use caution when draining hot coolant.

Caution

- Do not use alcohol- or methanol-based coolant.
- Use only soft (demineralized) water in the coolant mixture.

1. Remove the radiator cap and loosen the drain plug.
2. Drain the coolant into a suitable container.
3. Flush the cooling system with water until all traces of color are gone; then let the system drain completely.
4. Install the drain plug.
5. Perform air bleeding. (Refer to page E-6.)

AIR BLEEDING

When refilling the cooling system after draining the coolant, perform the following.

1. Slowly fill the radiator with ethyleneglycol-based coolant up to the filler neck. Refer to the table on page E-5 for the proper amount.

Filling pace:

1.0 L {1.1 US qt, 0.9 Imp qt}/min. max

Coolant capacity

8.8 L {9.3 US qt, 7.7 Imp qt}

2. Fill the coolant reservoir up to the F mark.
3. Install the coolant filler cap and the radiator cap securely and start the engine.
4. Run the engine at idle until it reaches normal operating temperature.

Caution

- **If the temperature increases beyond normal, there is excessive air in the system.**
- **Stop the engine and allow it to cool; then repeat Steps 1-4.**

5. Run the engine at 2,200-2,800 rpm for 5 minutes.
6. Stop the engine and allow it to cool.
7. Repeat Steps 1-6; then go to Step 8.

Warning



- **Do not remove the radiator cap until the engine is cool.**
- **Remove the coolant filler cap and the radiator cap carefully and slowly, using a thick rag.**

8. Remove the coolant filler cap and the radiator cap, and verify that the engine coolant level is near the filler neck. If not, repeat Steps 1-8.
9. Fill the reservoir to the F mark.

37U0EX-0J6

RADIATOR CAP

PREPARATION
SST

<p>49 9200 145</p> <p>Adapter set, radiator cap tester</p> 	<p>For inspection of radiator cap valve</p>	<p>49 9200 147</p> <p>Adapter B (Part of 49 9200 145)</p> 	<p>For inspection of radiator cap valve</p>
--	---	---	---

05U0EX-014

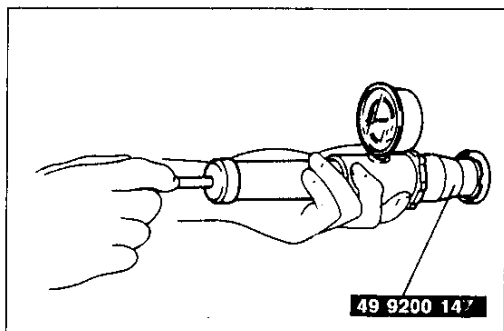

37U0EX-007

INSPECTION
Radiator Cap Valve

1. Remove foreign material (such as water residue) from between the radiator cap valve and the valve seat.
2. Attach the radiator cap to a radiator cap tester (commercially available) by using the **SST**. Apply pressure gradually to **113–142 kPa {1.15–1.45 kgf/cm², 16.4–20.6 psi}**.
3. Wait about **10 seconds**. Verify that the pressure has not decreased.
4. If not as specified, replace the radiator cap.

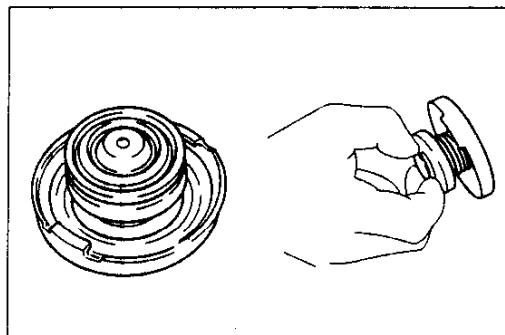

37U0EX-008

Negative Pressure Valve

1. Pull the negative pressure valve to open it. Verify that it closes completely when released.
2. Check for damage on the contact surfaces and for cracked or deformed seal packing.
3. Replace the radiator cap if a problem is found.

E

RADIATOR AND ELECTRIC COOLING FAN

RADIATOR AND ELECTRIC COOLING FAN

REMOVAL / INSTALLATION

1. Raise the vehicle and position it on safety stands.
2. Disconnect the negative battery cable.
3. Drain the engine coolant.
4. Remove in the order shown in the figure, referring to **Removal Note**.
5. Install in the reverse order of removal.

STEP 1

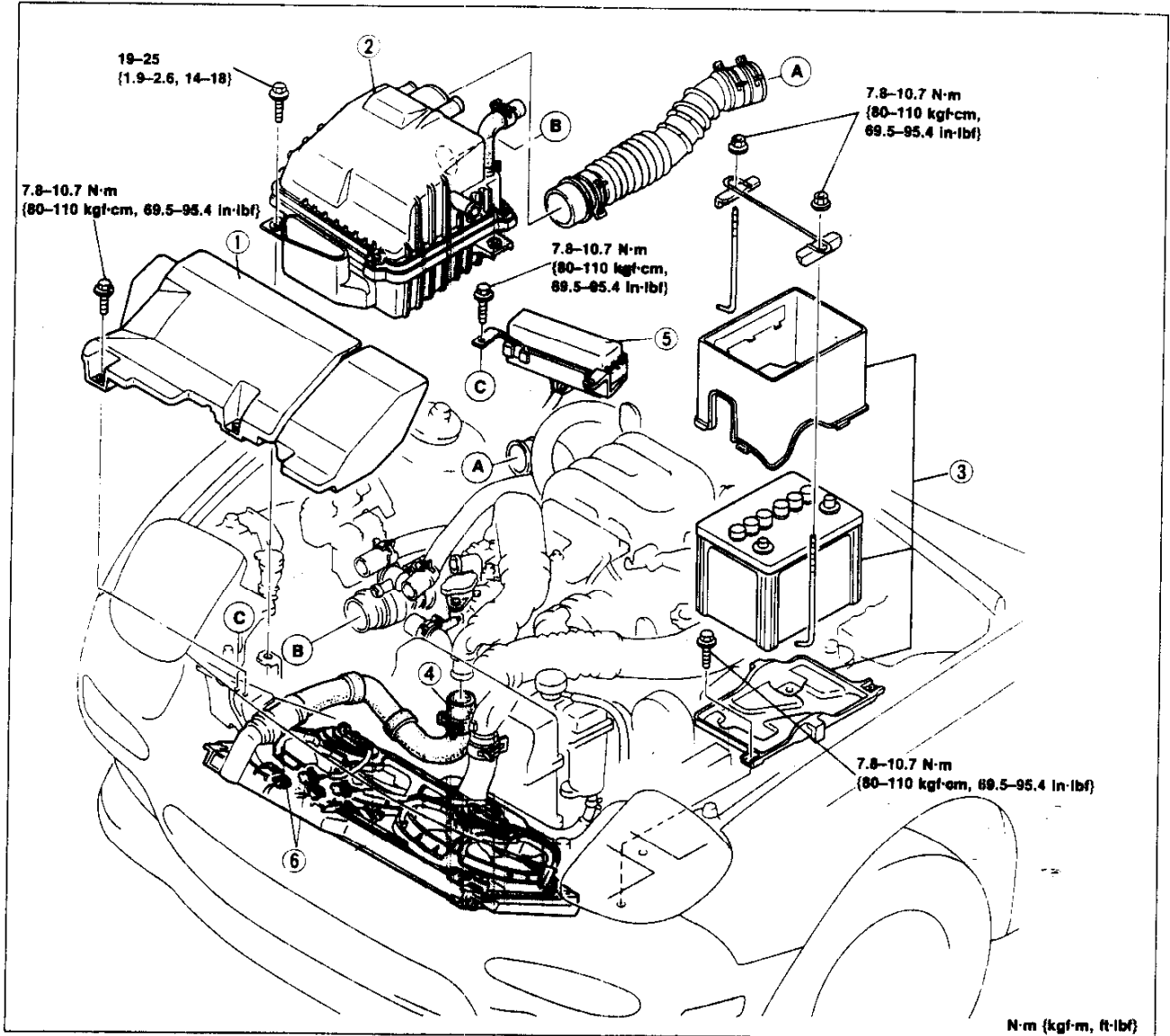

37U0EX-0C9

1. Fresh air duct
2. Air cleaner assembly
3. Battery and carrier
4. Radiator hose (upper)

5. Relay box
6. Cooling fan connector

STEP 2

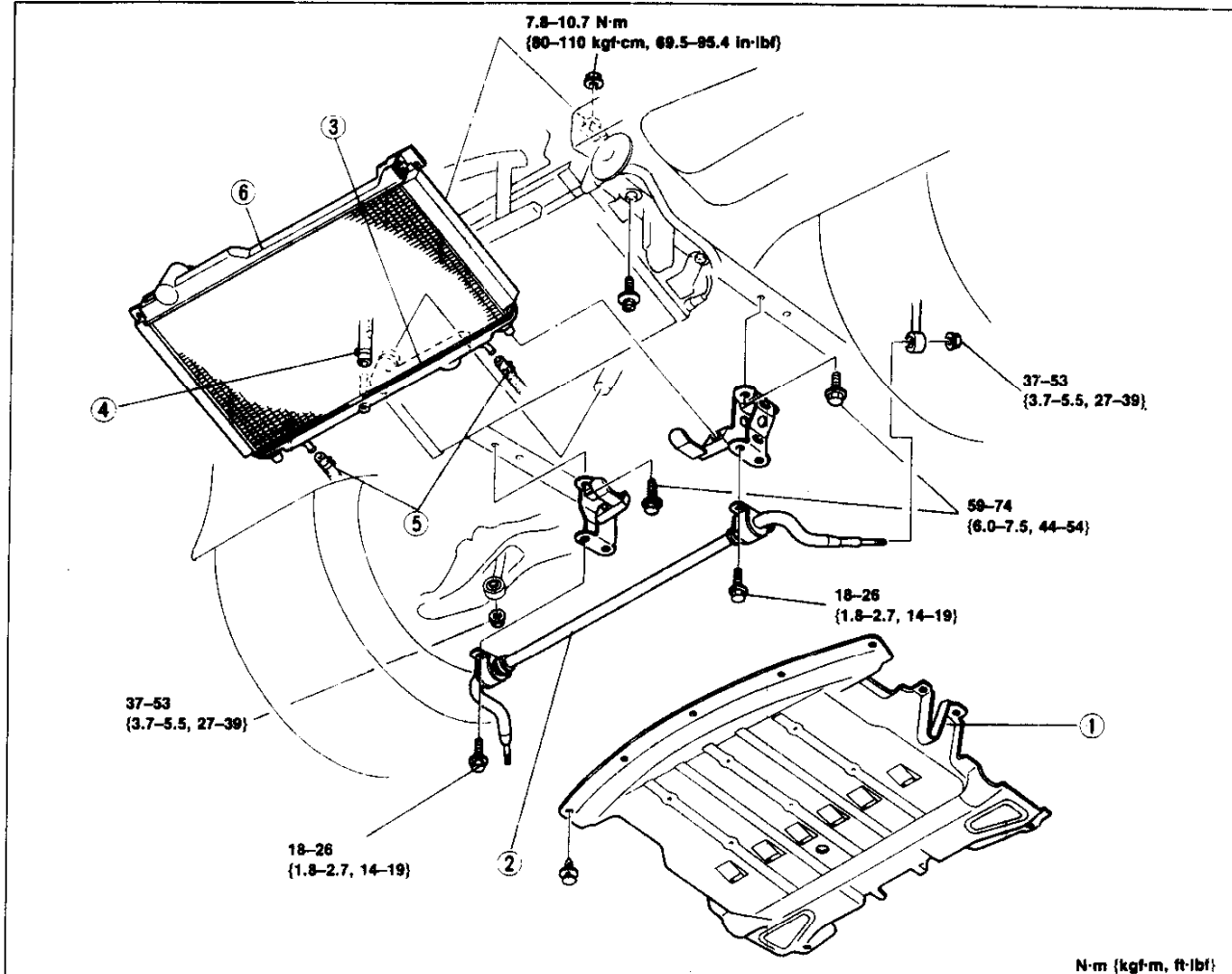

37U0EX-C10

- 1. Undercover
- 2. Stabilizer and bracket
Service Section R
- 3. Radiator hose (lower)
- 4. Air separation hose

- 5. Oil cooler hose (A/T)
- 6. Radiator and cooling fan
Removal Note below
Inspection page E-10

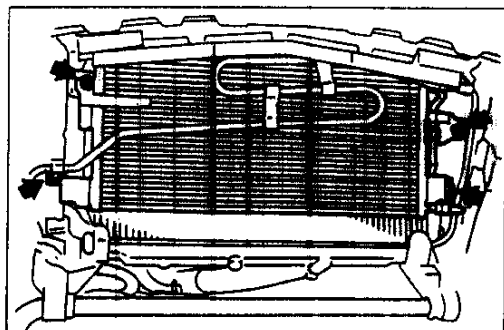

37U0EX-011

Removal Note Radiator and cooling fan

1. Remove the bolts shown in the figure.
2. Position the A/C condenser away from the radiator and secure it with wire.

Caution

- Do not disconnect the A/C piping.

E

RADIATOR AND ELECTRIC COOLING FAN

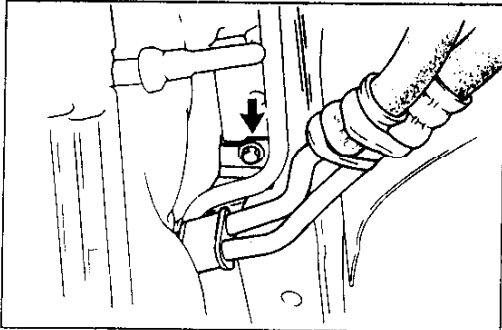

37U0EX-012

3. Remove the P/S oil pipe bracket shown in the figure.

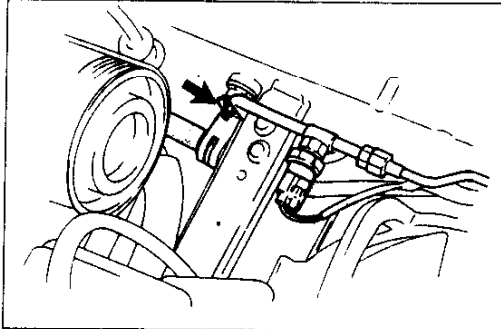

37U0EX-013

4. Remove the A/C high-pressure pipe bracket as shown in the figure.

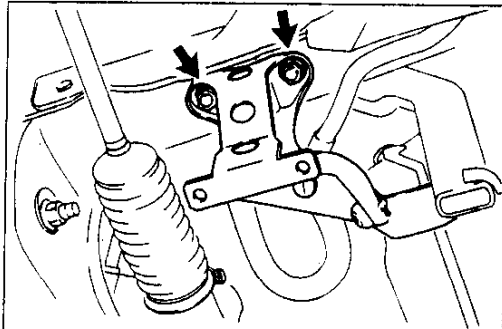

37U0EX-014

Caution
● Do not drop the radiator and electric cooling fan.

5. Remove the radiator bracket.

Caution
● Do not damage the condenser.

6. Remove the radiator and electric cooling fan.

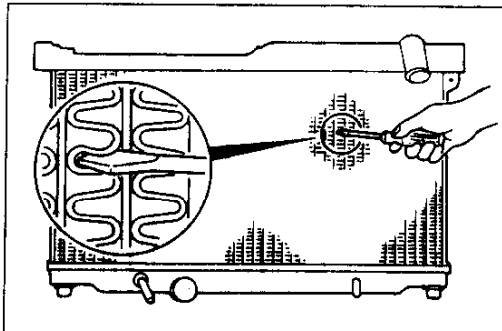

37U0EX-015

INSPECTION

Radiator

Check for the following and repair or replace the radiator as necessary.

1. Cracks, damage and water leakage.
2. Bent fins (repair with a screwdriver).
3. Damaged radiator inlet, outlet, and hose connectors.

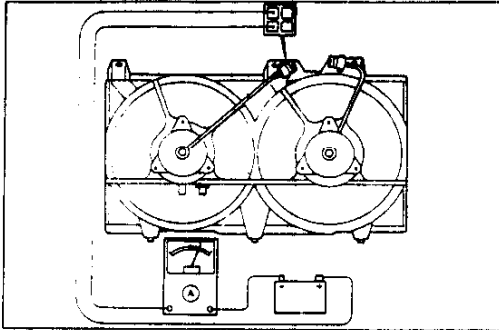

37U0EX-016

Fan Motor (Three-speed type)

1. Verify that the battery is fully charged.
2. Disconnect the fan motor connectors.
3. Connect battery voltage and an ammeter as shown to the fan motor connector for low-speed inspection.
4. Verify that the fan motor operates smoothly at the standard current .

Current: 5.8–11.8A

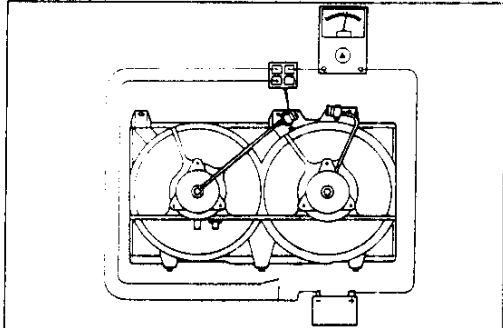

37U0EX-017

5. Connect battery voltage, an ammeter, and a switch to the fan motor connector as shown for medium-speed inspection.
6. Verify that the fan motor operates smoothly at the standard current or less with the switch ON.

Current: 6.5–12.5A

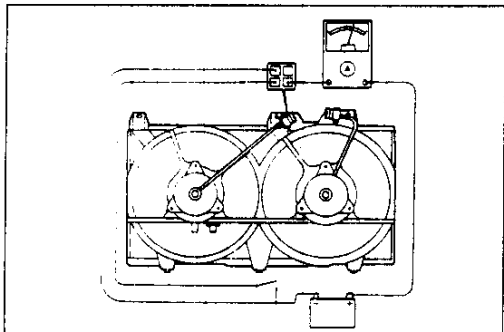

37U0EX-018

7. Connect battery voltage, an ammeter, and a switch to the fan motor connector as shown for high-speed inspection.
8. Verify that the fan motor operates smoothly at the standard current or less with the switch ON.

Current: 10.6–16.6A

9. Check the other fan motor as described above.
10. If a fan motor does not operate as specified, replace it.

E

RADIATOR AND ELECTRIC COOLING FAN

REPLACEMENT

1. Remove in the order shown in the figure.
2. Install in the reverse order of removal.

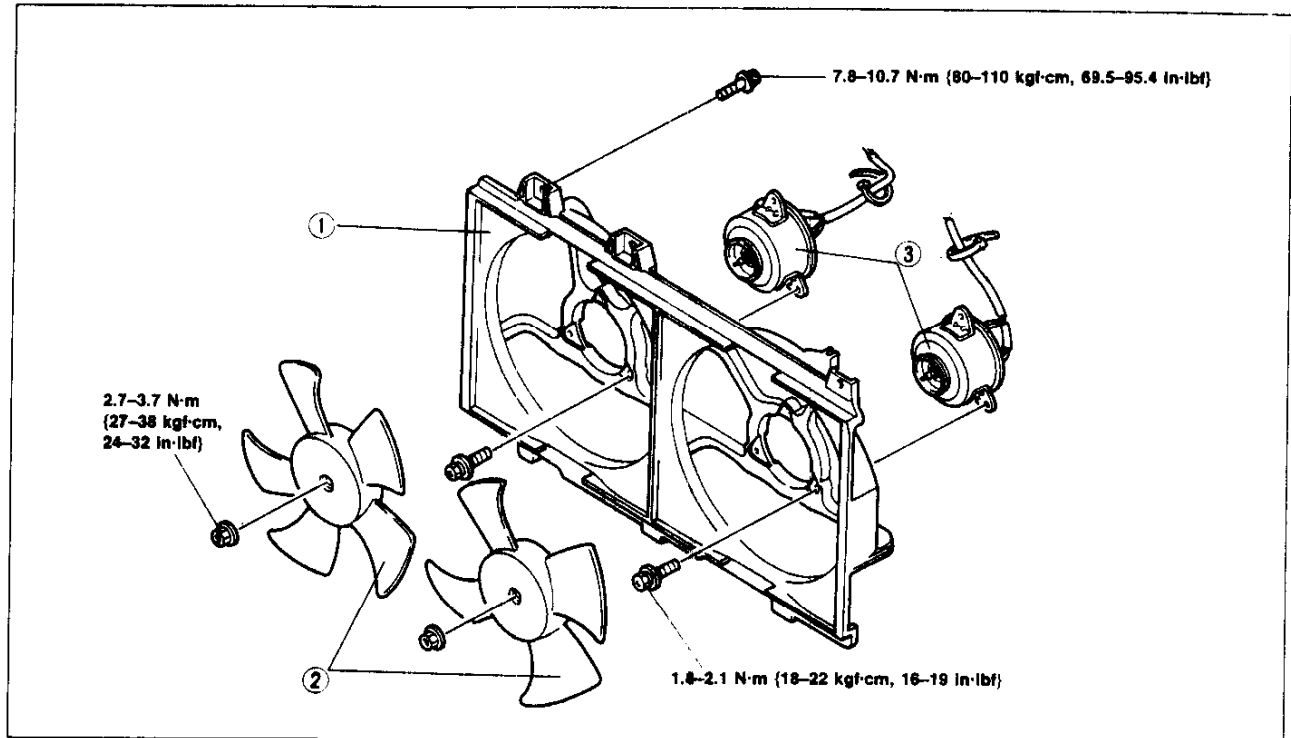

37U0EX-0'9

1. Radiator cowling
2. Fan

3. Fan motor

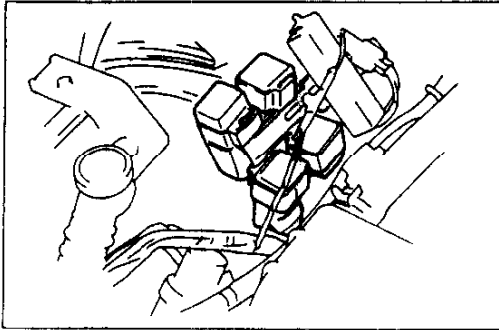

37U0EX-020

FAN RELAY

REMOVAL / INSTALLATION

Slide the fan relays off the bracket.

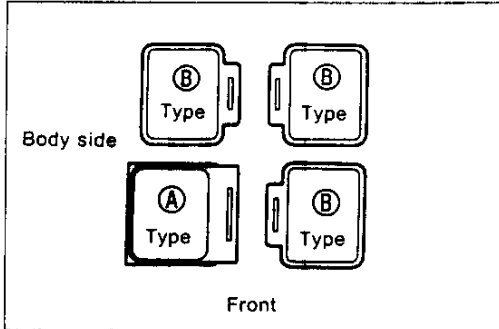

37U0EX-021

Note

● The relay positions are as shown in the figure.

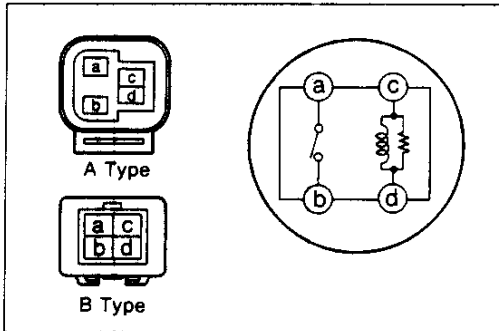

37U0EX-022

INSPECTION

1. Check continuity of the relay as shown.

Terminal	Continuity
a-b	No
c-d	Yes

- Apply 12V between terminals c and d. Check for continuity between terminal a and b.
- If not as specified, replace the fan relay.

Steps After Installation

- Fill the radiator with the specified amount and type of engine coolant. (Refer to page E-5.)
- Connect the negative battery cable.
- Start the engine and check for leaks.
- Bleed the cooling system. (Refer to page E-6.)

THERMOSTAT

REMOVAL / INSTALLATION

1. Disconnect the negative battery cable.
2. Drain the engine coolant.
3. Remove in the order shown in the figure.
4. Install in the reverse order of removal, referring to **Installation Note**.

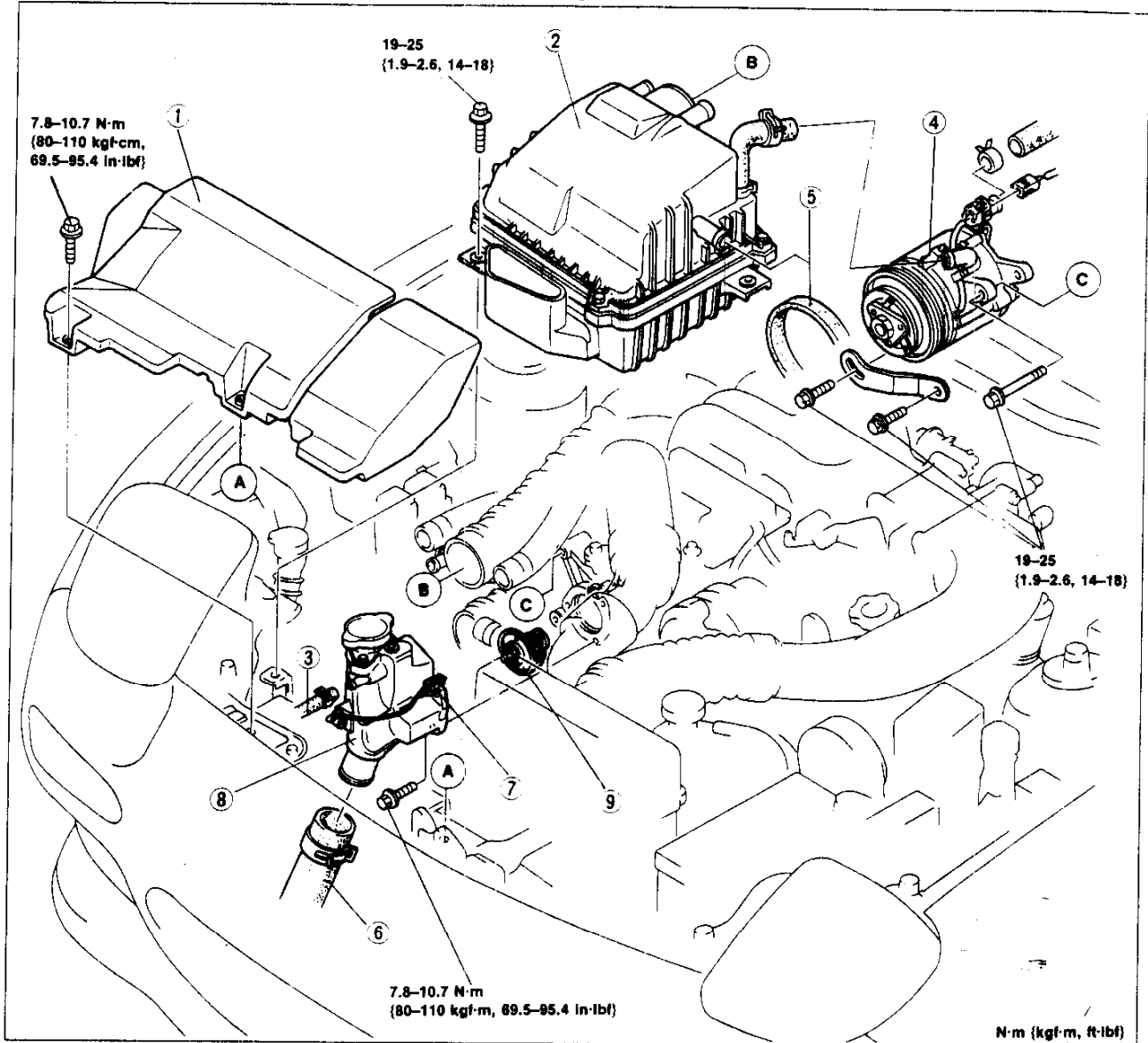

37U0EX-023

1. Fresh air duct
 2. Air cleaner assembly
 3. Water hose
 4. Air pump
 5. Drive belt
- Service Section C

6. Radiator hose (upper)
 7. Coolant level sensor connector
 8. Thermostat cover
 9. Thermostat and gasket
- Inspection page E-15
 Installation Note page E-15

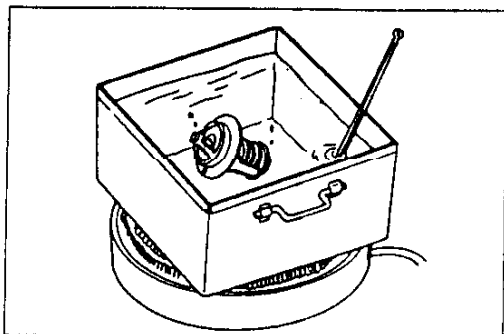

37U0EX-024

INSPECTION

1. Visually check that the thermostat valve is airtight.
2. Place the thermostat and a thermometer in water.
3. Heat the water and check the following.

Initial-opening temperature:

80.5–83.5°C {177–182°F}

Full-open temperature: 95°C {203°F}

Full-open lift: 8.0–10 mm {0.31–0.39 in} min.

4. Check the thermostat gasket; if damaged, replace the thermostat assembly.

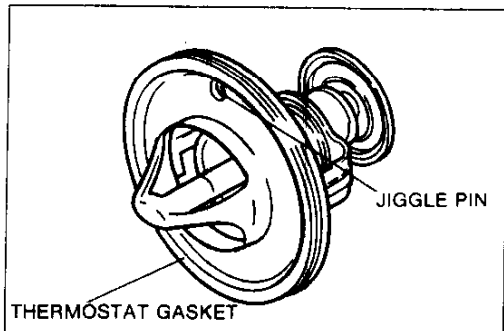

37U0EX-025

Installation Note

Thermostat

Install the thermostat into the thermostat case with the jiggle pin at the top.

Steps After Installation

1. Fill the radiator with the specified amount and type of engine coolant. (Refer to page E-5.)
2. Connect the negative battery cable.
3. Start the engine and check for leaks.
4. Bleed the cooling system. (Refer to page E-6.)

37U0EX-026

WATER PUMP AND WATER THERMOSWITCH

REMOVAL / INSTALLATION

1. Disconnect the negative battery cable.
2. Drain the engine coolant.
3. Remove in the order shown in the figure (page E-14), referring to **Removal Note**.
4. Install in the reverse order of removal.

37U0EX-027

E

WATER PUMP AND WATER THERMOSWITCH

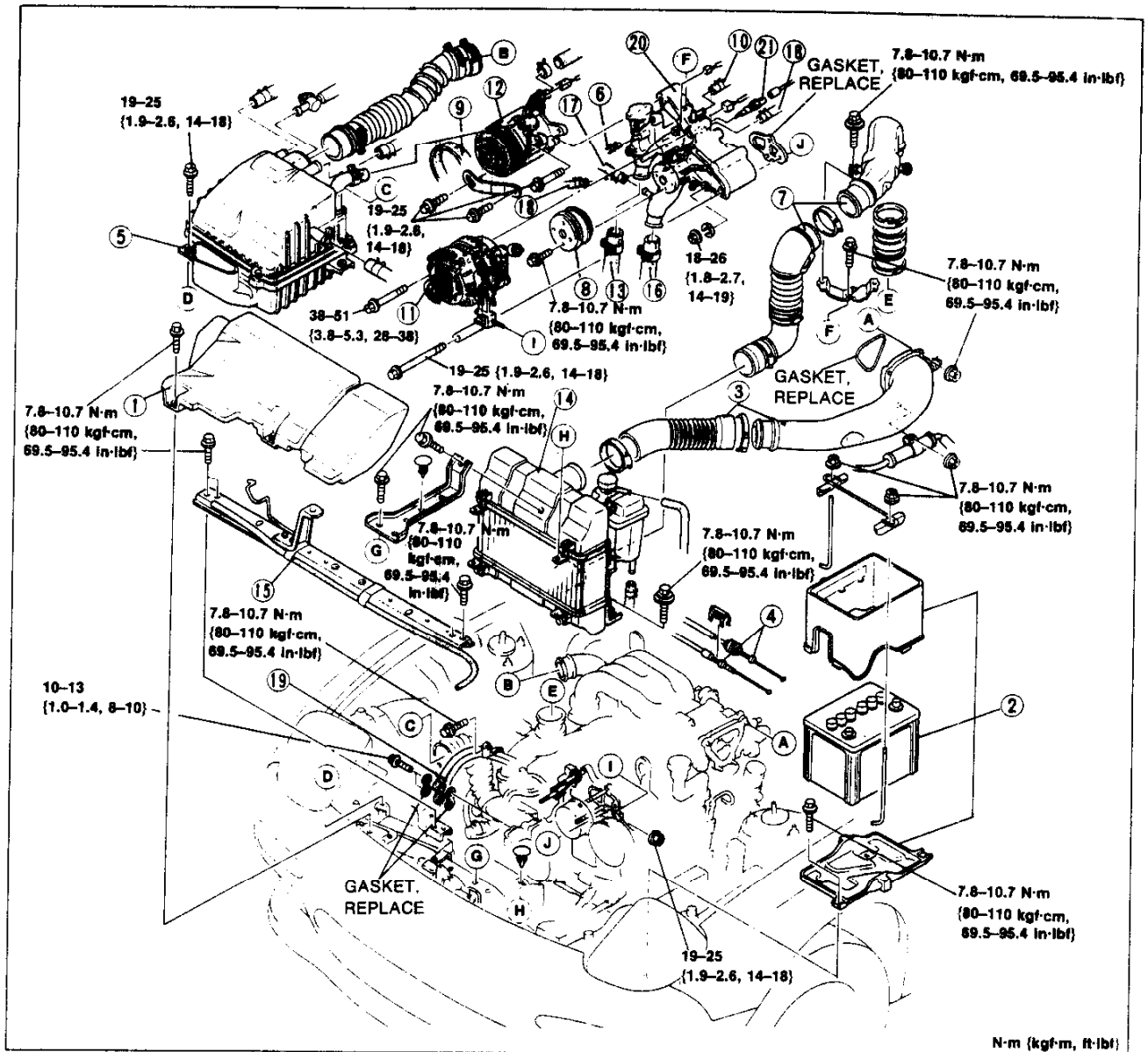

N-m (kgf-m, ft-lbf)

37U0EX-0:8

- 1. Fresh air duct
- 2. Battery and carrier
- 3. Air funnel and air hose
- 4. Accelerator cable
- Service Section F
- 5. Air cleaner assembly
- 6. Water hose (filler port)
- 7. Air pipe and air hose
- 8. Water pump pulley
- 9. Drive belt
- Service Section C
- 10. Water hose (water pump body)

- 11. Alternator and strap
- 12. Air pump and strap
- 13. Radiator hose (upper)
- 14. Intercooler and air separation tank
- Removal Note page E-17
- 15. Subframe
- 16. Radiator hose (lower)
- 17. Heater hose
- 18. Water hose (water pump body)
- 19. Metering oil tube
- 20. Water pump and pump body
- Removal Note page E-17
- 21. Water thermostat
- Inspection page E-17
- Installation Note page E-17

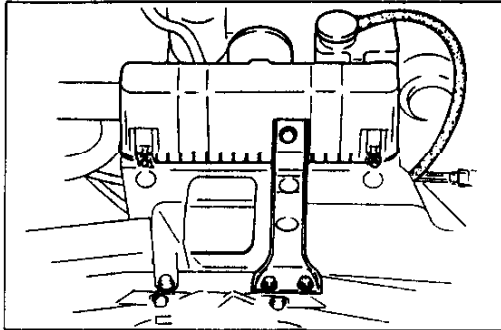

37U0EX-029

Removal Note
Intercooler and air separation tank

Do not remove the air duct from the body.

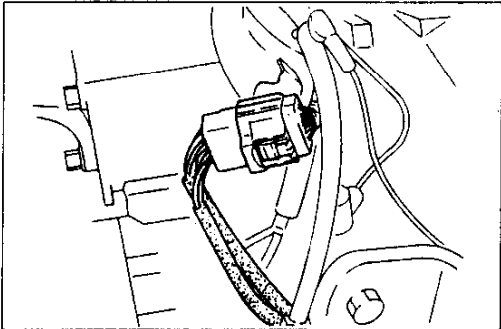

37U0EX-030

Water pump and pump body

1. Remove the metering oil pump connector from the engine hanger.

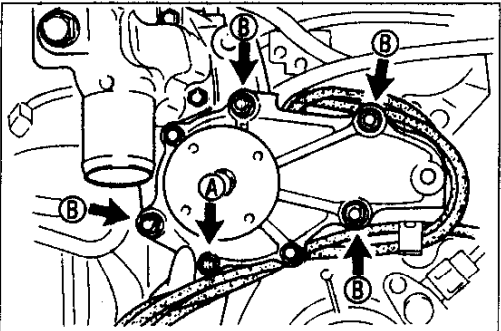

37U0EX-031

2. Remove the bolt A shown in the figure.
3. Position the metering oil tube and metering oil pump harness under the lower radiator hose.
4. Remove the nuts B shown in the figure.
5. Remove the water pump and pump body.

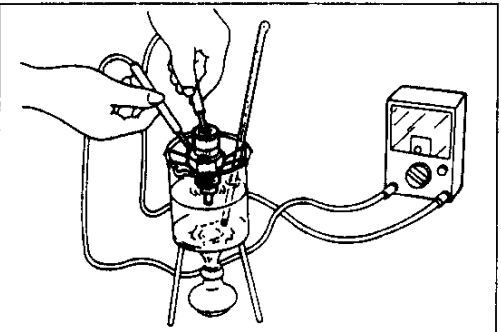

37U0EX-032

INSPECTION

Water Thermostatic Switch

1. Place the switch and a thermometer in water.
2. Heat the water gradually and check resistance of the switch.

Coolant	Resistance
101°C {214°F}	0.5 Ω max.
108°C {226°F}	1 MΩ min.

3. If not as specified, replace the water thermostatic switch.

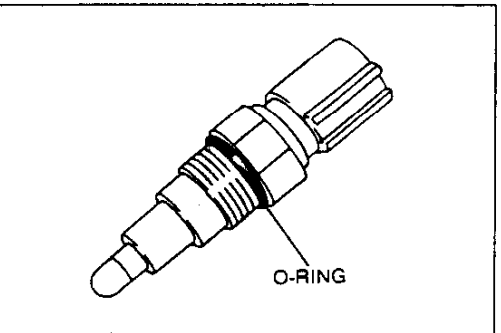

37U0EX-033

Installation Note

Water thermostatic switch

1. Apply a small amount of engine coolant to the new O-ring.

Caution

● Do not use an impact wrench for installation.

2. Install the water thermostatic switch.

Tightening torque:

5.9–8.8 N·m {60–90 kgf·cm, 52–78 in·lbf}



1

.

2

3