

PROPELLER SHAFT

OUTLINE	L - 2
SPECIFICATIONS	L - 2
TROUBLESHOOTING GUIDE	L - 2
PROPELLER SHAFT	L - 3
PREPARATION	L - 3
REMOVAL/INSPECTION/ INSTALLATION	L - 3

37U0LX-001



L

OUTLINE , TROUBLESHOOTING GUIDE

OUTLINE

SPECIFICATIONS

Item	Engine / Transmission		RE 13B (TURBO)	
			R15M-D (MT)	RB4A-EL (AT)
Length	mm {in}	L	863 {33.98}	875 {34.45}
Outer diameter	mm {in}	D	75 {3.0}	

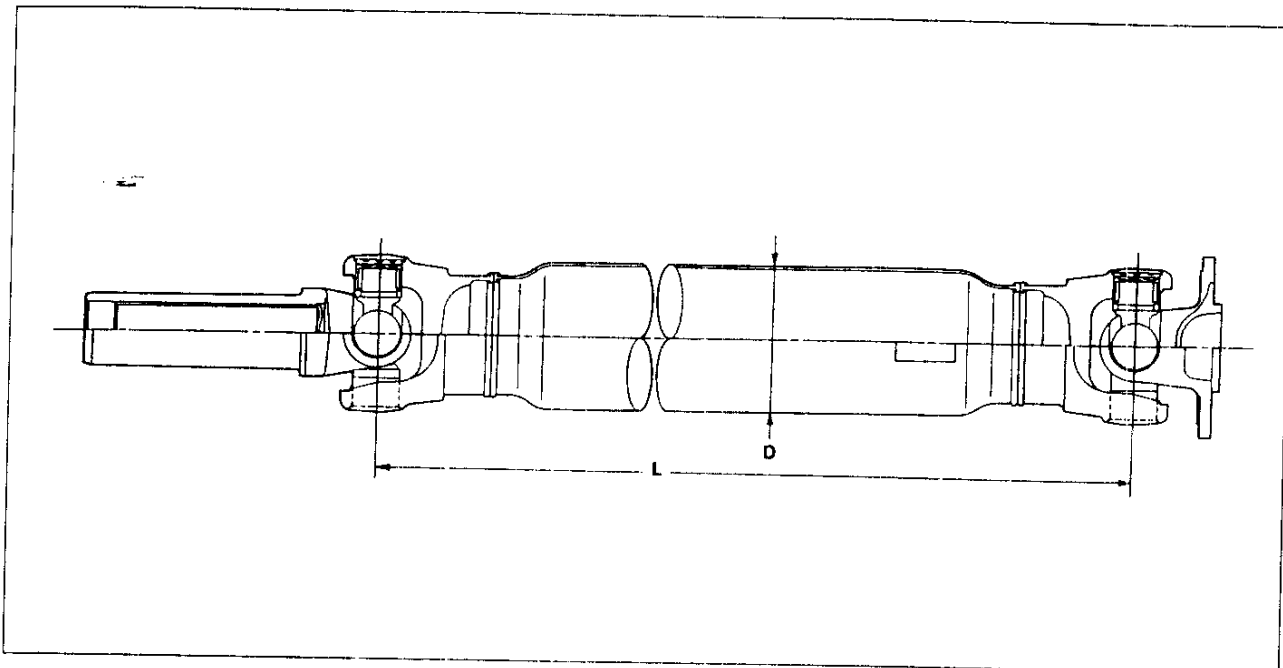

37U0LX-002

TROUBLESHOOTING GUIDE

Problem	Possible cause	Action	Page
Vibration	Bent propeller shaft	Replace	L-3
	Worn or damaged universal joint	Replace	L-3
	Worn slip yoke or splines	Replace	L-3
	Damaged slip yoke	Replace	L-3
Abnormal noise	Damaged universal joint yoke	Replace	L-3
	Worn or damaged universal joint	Replace	L-3
	Damaged slip yoke	Replace	L-3
	Damaged universal joint yoke	Replace	L-3
	Worn slip yoke or splines	Replace	L-3

37U0LX-003

PROPELLER SHAFT

PREPARATION
SST

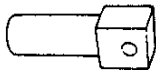
49 S120 440		For prevention of oil leakage
Holder, mainshaft		

37U01 X-004

REMOVAL / INSPECTION / INSTALLATION

1. Remove in the order shown in the figure, referring to **Removal Note**.
2. Inspect all parts and repair or replace as necessary.
3. Install in the reverse order of removal, referring to **Installation Note**.

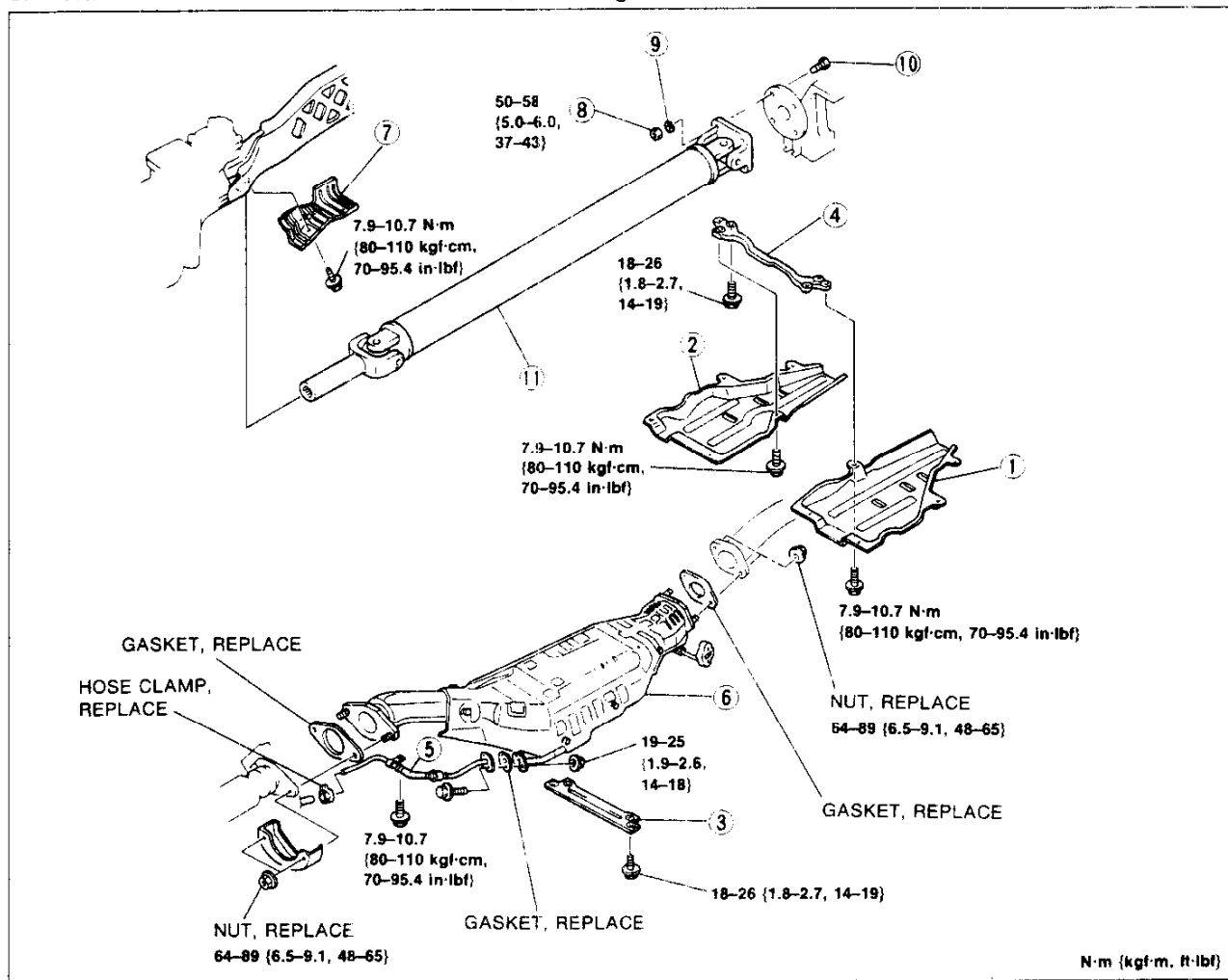

37U01 X-005

- | | | |
|---|--|--|
| <ol style="list-style-type: none"> 1. Left undercover 2. Right undercover 3. Tunnel reinforcement (center) 4. Tunnel reinforcement (rear) | <ol style="list-style-type: none"> 5. Secondary air injection pipe 6. Catalytic converter assembly 7. Cover 8. Nut 9. Lock washer 10. Bolt | <ol style="list-style-type: none"> 11. Propeller shaft
Removal Note page L-4
Inspection page L-4
Installation Note page L-4 |
|---|--|--|

PROPELLER SHAFT

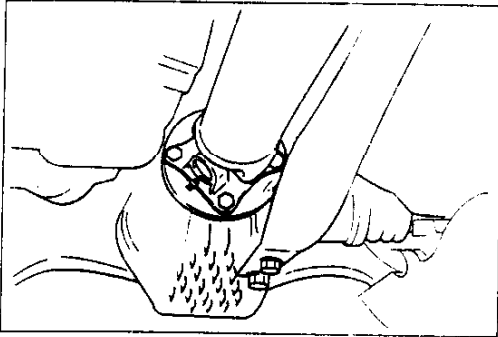

37U0LX-006

Removal Note Propeller shaft

1. Before removing the propeller shaft, mark the companion flange and yoke for correct reassembly.
2. Remove the propeller shaft from the extension housing, and immediately install the **SST** to prevent oil leakage.

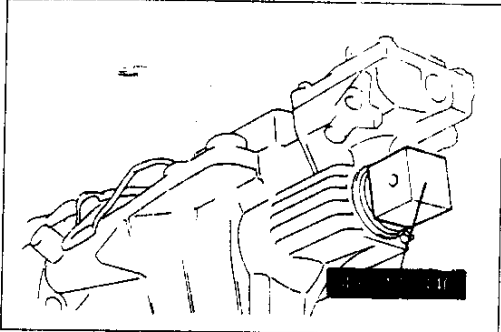

37U0LX-007

Inspection Propeller shaft

Note

- Before inspecting, clean the propeller shaft (except for the universal joint) with a steam cleaner or solvent.

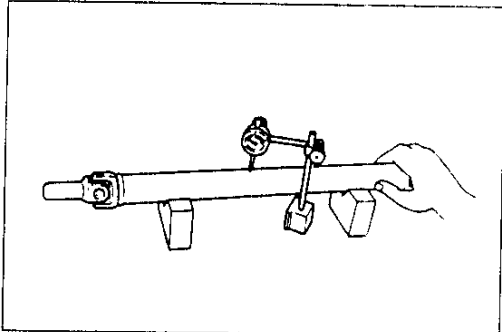

37U0LX-008

1. Measure the propeller shaft runout with a dial indicator.
2. If the runout is excessive, replace the propeller shaft assembly.

Runout: 0.4mm {0.02in} max.

3. Move the universal joint in the direction shown, and inspect joint play.

Note

- Starting torque

Front yoke:

30-98 N·m {3.0-10 kgf·m, 22-72 ft·lbf}

Rear yoke:

30-98 N·m {3.0-10 kgf·m, 22-72 ft·lbf}

4. If there is excessive play or the starting torque is not within specification, replace the propeller shaft.

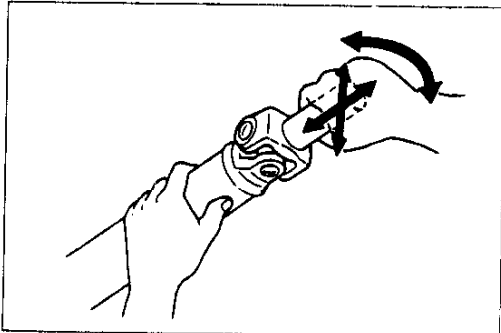

37U0LX-009

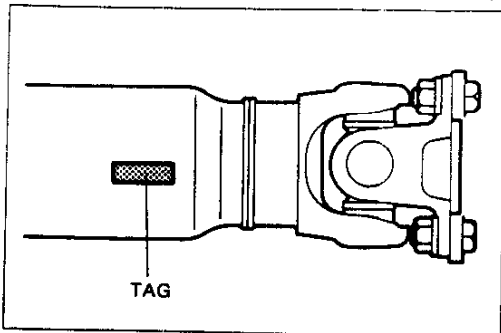

37U0LX-010

Installation Note Propeller shaft

Caution

- If installing a new propeller shaft, align the differential companion flange precast marking with the tag on the propeller shaft.

PROPELLER SHAFT

L

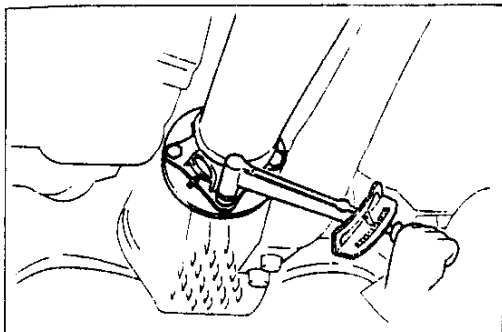

37JCLX-011

1. Align the marks made during removal, and install the propeller shaft.

Tightening torque:

50–58 N·m {5.0–6.0 kgf·m, 37–43 ft·lbf}

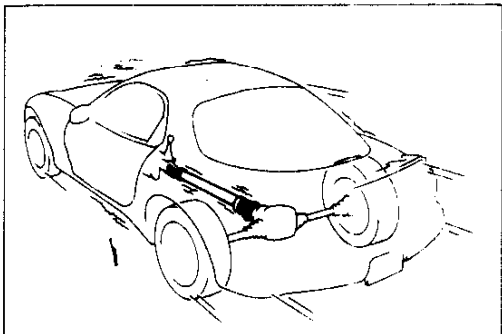

37UCLX-012

2. Perform a road test and verify that there is no noise or vibration when driving the vehicle.
3. If noise or vibration comes from the propeller shaft assembly, replace it.

L

