

Before beginning any service procedure, refer to the 1993 RX-7 Body Electrical Troubleshooting Manual; see section S for air bag system precautions and J1 for audio anti-theft system precautions.

BRAKING SYSTEM

INDEX	P - 2
OUTLINE	P - 4
SPECIFICATIONS	P - 4
CONVENTIONAL BRAKE SYSTEM	P - 5
PREPARATION	P - 5
TROUBLESHOOTING GUIDE	P - 6
AIR BLEEDING	P - 7
BRAKE LINE	P - 7
BRAKE FLUID	P - 8
VACUUM LINE	P - 8
BRAKE PEDAL	P - 9
MASTER CYLINDER	P -11
POWER BRAKE UNIT	P -16
PROPORTIONING BYPASS VALVE	P -19
FRONT BRAKE (DISC)	P -20
DISC PAD (FRONT)	P -23
DISC PLATE (FRONT)	P -23
CALIPER (FRONT)	P -25
REAR BRAKE (DISC)	P -26
DISC PAD (REAR)	P -28
DISC PLATE (REAR)	P -29
CALIPER (REAR)	P -30
PARKING BRAKE SYSTEM	P -32
TROUBLESHOOTING GUIDE	P -32
PARKING BRAKE (LEVER TYPE)	P -32
PARKING CABLE (LEVER TYPE)	P -33
PARKING BRAKE LEVER	P -34
ANTI-LOCK BRAKE SYSTEM (ABS)	P -36
PREPARATION	P -36
TROUBLESHOOTING GUIDE	P -37
SERVICE POINTS	P -52
HYDRAULIC UNIT	P -55
ABS CONTROL UNIT	P -57
WHEEL-SPEED SENSOR (FRONT)	P -58
SENSOR ROTOR (FRONT)	P -59
WHEEL-SPEED SENSOR (REAR)	P -60
SENSOR ROTOR (REAR)	P -61
RELAY	P -62

INDEX

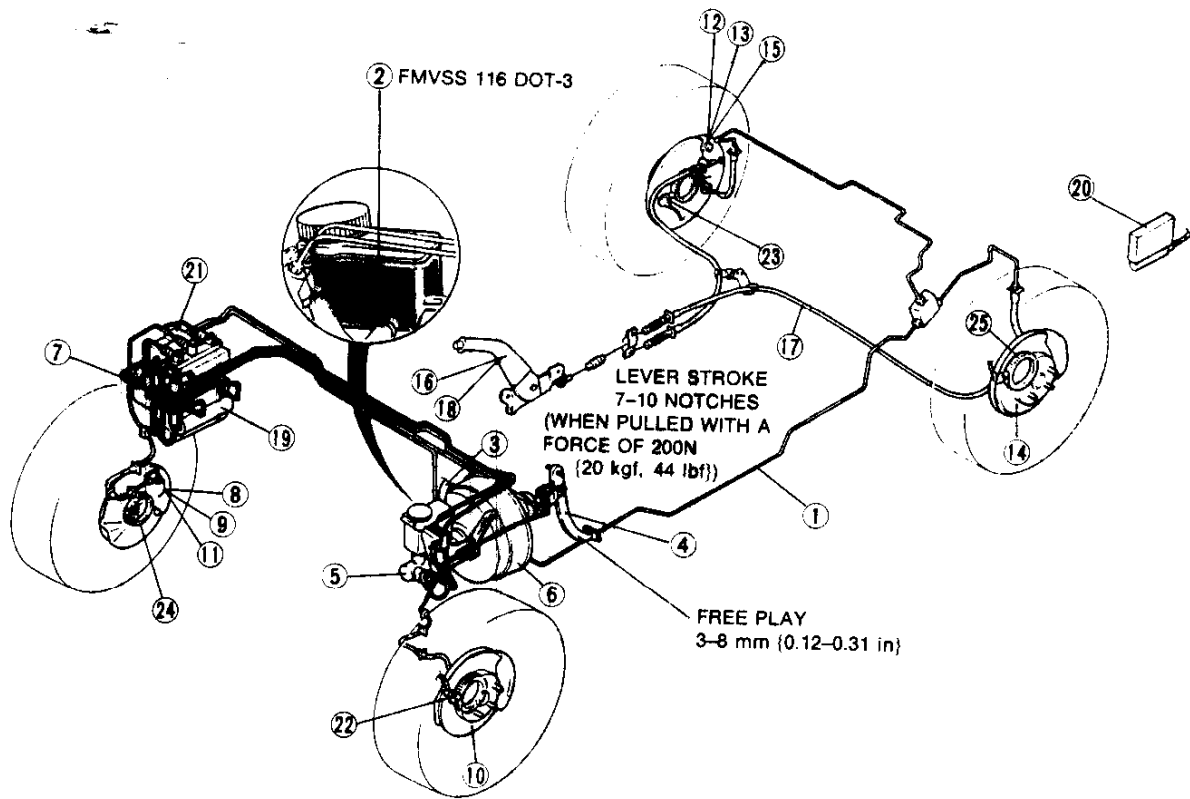

1. Brake line
 Inspection page P- 7
 Removal / Installation
 page P- 7
2. Brake fluid
 Inspection page P- 8
 Replacement
 page P- 8
3. Vacuum line
 Inspection page P- 8
4. Brake pedal
 Inspection (on-vehicle)
 page P- 9
 Removal / Inspection /
 Installation .. page P-10
5. Master cylinder
 Removal / Installation
 page P-11
 Disassembly / Inspection /
 Assembly page P-15
6. Power brake unit
 Inspection (on-vehicle)
 page P-16
 Removal /
 Installation .. page P-18
7. Proportioning bypass valve
 Inspection page P-19
 Replacement
 page P-20
8. Front brake (disc)
 Inspection (on vehicle)
 page P-20
 Removal / Inspection /
 Installation .. page P-21
9. Disc pad (front)
 Replacement
 page P-23
10. Disc plate (front)
 Inspection page P-23
11. Caliper (front)
 Disassembly / Inspection /
 Assembly page P-25
12. Rear brake (disc)
 Inspection (on-vehicle)
 page P-26
 Removal / Inspection /
 Installation .. page P-27
13. Disc pad (rear)
 Replacement .. page P-28
14. Disc plate (rear)
 Inspection page P-29
15. Caliper (rear)
 Disassembly / Inspection /
 Assembly page P-30
16. Parking brake (lever type)
 Inspection page P-32
 Adjustment page P-32
17. Parking cable (lever type)
 Removal / Inspection /
 Installation .. page P-33
18. Parking brake lever
 Removal / Inspection /
 Installation .. page P-34
19. Hydraulic unit
 Removal / Installation
 page P-55
 Disassembly / Inspection /
 Assembly page P-56
20. ABS control unit
 Removal / Installation
 page P-57
21. Relay
 Removal / Installation
 page P-62
 Inspection page P-62
22. Wheel-speed sensor (front)
 Removal / Installation
 page P-58
 Inspection page P-58
23. Wheel-speed sensor (rear)
 Removal / Installation
 page P-60
 Inspection page P-60
24. Sensor rotor (front)
 Removal / Installation
 page P-59
25. Sensor rotor (rear)
 Removal / Installation
 page P-61

37U0PX-003

OUTLINE





SPECIFICATIONS

Item		Specifications	
Brake pedal			
Type		Suspended	
Lever ratio		4.1 : 1	
Maximum stroke	mm {in}	135 {5.31}	
Master cylinder			
Type		Tandem (with level sensor) Portless, recessed type	
Bore	mm {in}	23.8 {0.94}	
Front brake			
Type		Disc (ventilated)	
Cylinder bore	mm {in}	36.1 {1.42}	
Pad dimension (area × thickness)	mm ² × mm {in ² × in}	Outer	4500 × 10.3 {6.97 × 0.41}
		Inner	4500 × 9.3 {6.97 × 0.37}
Disc plate dimension (outer diameter × thickness)	mm × mm {in × in}		294.0 × 22.0
			{11.57 × 0.87}
Rear brake			
Type		Disc (ventilated)	
Cylinder bore	mm {in}	34.9 {1.37}	
Pad dimension (area × thickness)	mm ² × mm {in ² × in}		3210 × 8.0
			{4.98 × 0.31}
Disc plate dimension (outer diameter × thickness)	mm × mm {in × in}		294.0 × 20.0
			{11.57 × 0.79}
Power brake unit			
Type		Vacuum multiplier	
Size	mm {in}	209.5 + 215.2 {8 + 8}	
Rear wheel hydraulic control system			
Type		Proportioning bypass valve	
Switching point (master cylinder pressure)	kPa {kgf/cm ² , psi}	3920 {40.0, 570}	
Parking brake			
Type		Mechanical two-rear-wheel control	
Operation system		Hand lever	
Brake fluid			
Type		FMVSS 116 DOT-3	

37U0PX-004

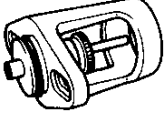
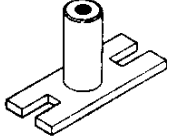
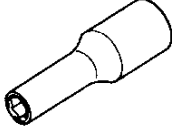
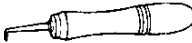
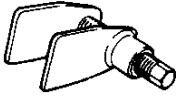
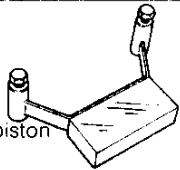
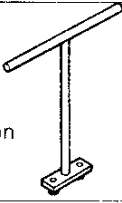
CONVENTIONAL BRAKE SYSTEM

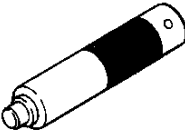
PREPARATION SST

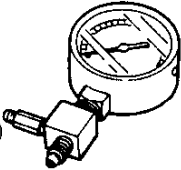
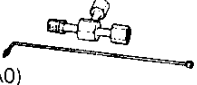
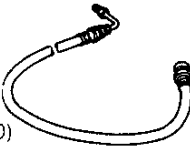
49 0259 770B Wrench, flare nut		For removal / installation of brake pipe	49 B043 001 Gauge, adjustment		For adjustment of push rod clearance
49 B043 003 lock tool, turning		For adjustment of push rod clearance	49 B043 004 Wrench, socket		For adjustment of push rod clearance
49 0208 701A Air out tool, boot		For removal of piston seal	49 0221 600C Expansion tool, disc brake		For installation of disc pads
49 F033 001 Stopper, disc brake piston		For removal of disc brake piston	49 FA18 602 Wrench, disc brake piston		For removal of disc brake piston
49 1285 071 Puller, bearing		For removal of bearing	49 B043 002 Installer, bearing		For installation of bearing
49 U043 0A0 Gauge set, oil pressure		For measurement of fluid pressure	49 U043 004 Gauge, oil pressure (Part of 49 U043 0A0)		For measurement of fluid pressure
49 U043 005 Joint (Part of 49 U043 0A0)		For measurement of fluid pressure	49 U043 006 Hose (Part of 49 U043 0A0)		For measurement of fluid pressure

37U0PX-005

P

CONVENTIONAL BRAKE SYSTEM

TROUBLESHOOTING GUIDE

Problem	Possible cause	Action	Page
Poor braking	Leakage of brake fluid	Repair	-
	Air in system	Bleed air	P-7
	Worn disc pad	Replace	P-23, 28
	Brake fluid, grease, oil, or water on disc pad	Clean or replace	P-23, 28
	Hardening of disc pad surface or poor contact	Grind or replace	P-23, 28
	Malfunction of caliper piston	Replace	P-25, 30
	Malfunction of master cylinder	Repair or replace	P-11, 15
	Malfunction of power brake unit	Replace	P-18
	Malfunction of check valve (vacuum hose)	Replace	P-8
	Damaged vacuum hose	Replace	P-8
	Deterioration of flexible hose	Replace	P-7
Malfunction of proportioning bypass valve (PBV)	Replace	P-20	
Brakes pull to one side	Worn disc pad	Replace	P-23, 28
	Brake fluid, grease, oil, or water on disc pad	Clean or replace	P-23, 28
	Hardening of disc pad surface or poor contact	Grind or replace	P-23, 28
	Abnormal wear, distortion, or runout of disc plate	Repair or replace	P-23, 29
	Malfunction of automatic adjuster	Repair or replace	P-25, 30
	Loose or damaged dust cover mounting bolt	Tighten or replace	Section M
	Malfunction of caliper piston	Replace	P-25, 30
	Worn or improperly adjusted wheel bearing preload	Adjust or replace	Section M
	Improper adjustment of wheel alignment	Adjust	Section R
Unequal tire air pressure	Adjust	Section Q	
Brakes do not release	No brake pedal play	Adjust	P-9
	Improper adjustment of push rod clearance	Adjust	P-11
	Clogged master cylinder return port	Clean	-
	Brake pad not returning properly	Repair	-
	Improper return or malfunction of caliper piston	Repair or Replace	P-25, 30
	Excessive runout of disc plate	Replace	P-23, 29
Improper adjustment of wheel bearing preload	Adjust or replace	Section M	
Pedal goes too far (excessive pedal stroke)	Air in system, insufficient brake fluid	Add fluid and bleed air	P-7, 8
	Improper adjustment of pedal play	Adjust	P-9
	Worn disc pad	Replace	P-23, 28
Abnormal noise or vibration during braking	Worn disc pad	Replace	P-23, 28
	Damaged pad	Grind or replace	P-23, 28
	Brakes do not release	Repair	-
	Foreign material or scratches on disc plate contact surface	Clean	-
	Loose caliper mounting bolt	Tighten	P-21, 27
	Damaged disc plate contact surface	Replace	P-21, 27
	Poor contact of pad	Repair or replace	P-23, 28
	Insufficient grease on sliding parts	Apply grease	-

37UOPX-006

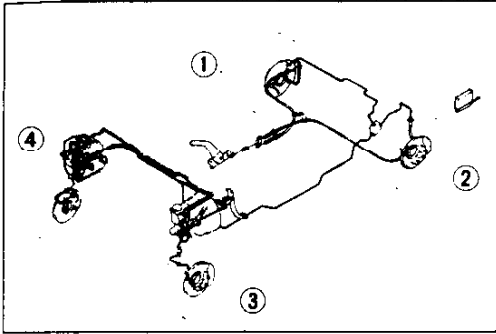

37U0PX-007

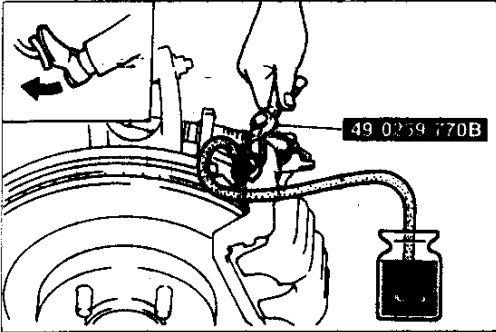

37U0PX-008

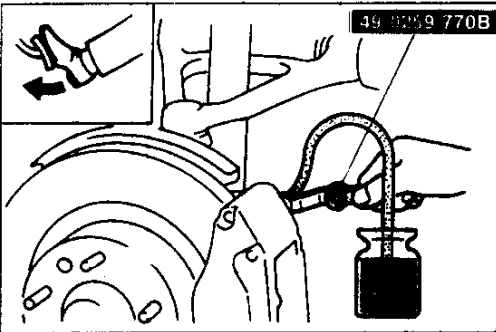

37U0PX-009

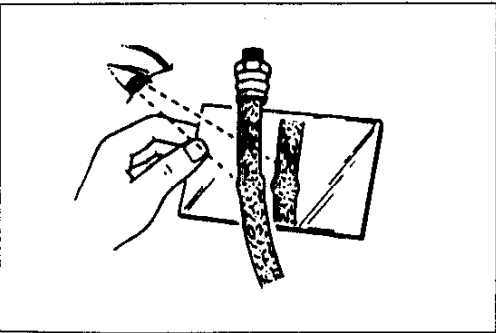

37U0PX-010

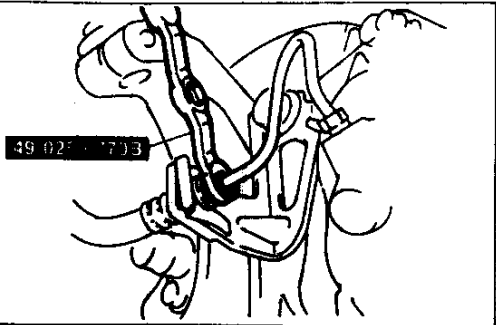

29U0PX-010

AIR BLEEDING

Caution

- The fluid in the reservoir must be maintained of the 3/4 level or higher during air bleeding.
- Do not spill brake fluid onto painted surfaces. If spilled, wipe it up immediately.

Note

- Air bleeding must be started at the bleeder screw farthest from the master cylinder.

1. Jack up the vehicle and support it on safety stands.
2. Remove the bleeder cap and attach a vinyl tube to the bleeder screw.
3. Place the other end of the vinyl tube in a clear container. Keep the tube immersed in brake fluid during air bleeding.
4. Have a helper depress the brake pedal several times, and then hold it in the depressed position.
5. Loosen the bleeder screw, drain out the fluid, and retighten the screw by using the **SST**.

Tightening torque:

5.9–8.8 N·m {60–90 kgf·cm, 53–78 in·lbf}

Note

- The two persons must stay in voice contact with each other.
- Be sure the pedal remains depressed until the bleeder screw is tightened.

6. Repeat Steps 4 and 5 until no air bubbles are seen.
7. Perform the above steps for the remaining wheels.
8. Check for correct brake operation.
9. Check that there is no fluid leakage. Be sure to clean away any spilled fluid with rags.
10. After bleeding the air, add brake fluid to the MAX level in the reservoir.

BRAKE LINE

Inspection

Check for the following and repair or replace parts as necessary.

1. Cracks, damage, and corrosion of brake lines
2. Damage to brake hose threads
3. Scars, cracks, and swelling of flexible hoses
4. All lines for fluid leakage

Removal / Installation

1. When disconnecting the flexible hose and brake line, loosen the nut by using the **SST**, then remove the holding clip.
2. When connecting the flexible hose, do not overtighten or twist it.
3. Install the holding clip and tighten the brake pipe nut by using the **SST**.
4. Verify that the hose does not contact other parts when the vehicle bounces or when the steering wheel is turned all the way to the left or right.
5. Bleed the air from the brake system. (Refer to above.)

CONVENTIONAL BRAKE SYSTEM

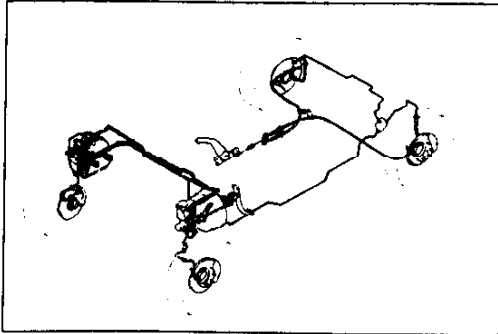

29U0PX-011

BRAKE FLUID

Inspection

1. Depress the brake pedal several times, and check the brake system for leaks.

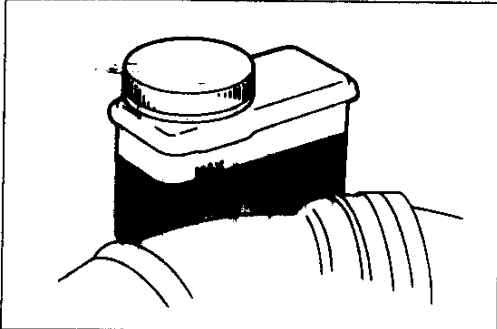

37U0PX-109

2. Verify the fluid level in the reservoir is between the MAX and MIN lines.
3. If the fluid level is extremely low, check the brake system for leaks.

Fluid specification: FMVSS 116 DOT-3

Replacement

Caution

- The fluid in the reservoir must be maintained at the 3/4 level or higher during air bleeding.
- Do not spill brake fluid onto painted surfaces. If spilled, wipe it up immediately.

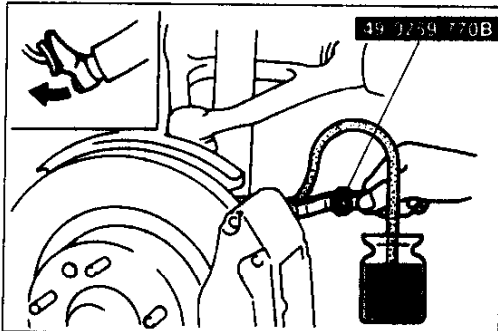

29U0PX-013

1. Remove the brake fluid from the reservoir by using a suction pump.
2. Fill the reservoir with clean brake fluid.
3. Attach a vinyl tube to the farthest bleeder screw and place the other end of the tube in a clear container.
4. Pump out the old brake fluid by loosening the bleeder screw and pumping the brake pedal until only clean fluid is expelled.
5. Perform the above for all bleeder screws.
6. Fill the reservoir to the specified level.

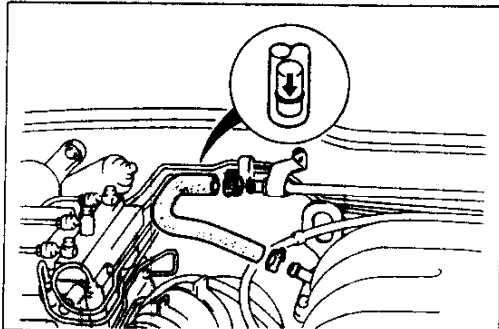

29U0PX-014

VACUUM LINE

Inspection

Note

- The check valve is pressed into the vacuum hose.
- The arrow on the hose indicates the direction of hose installation (toward engine).

1. Remove the clamps and remove the hose.
2. Apply suction and pressure to the hose from the engine side. Verify that air flows only toward the engine. If the air passes in both directions or not at all, replace the vacuum hose (together with the check valve).

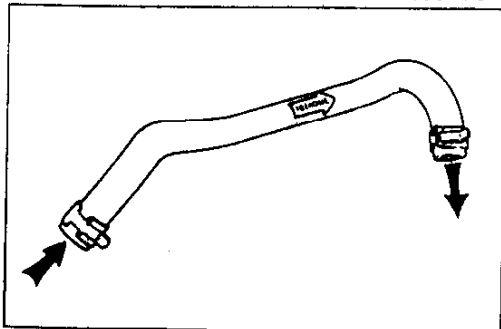

37U0PX-011

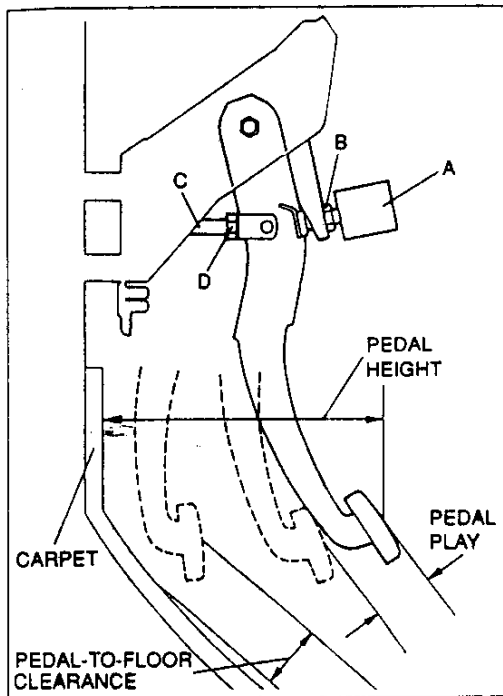

37U0PX-012

BRAKE PEDAL

Inspection (on-vehicle)

Pedal height inspection

Check if the distance from the center of the upper surface of the pedal pad to the carpet is as specified.

Pedal height: 164.5–176.0 mm {6.48–6.92 in} (with carpet)

Pedal height adjustment

1. Disconnect the stoplight switch connector.
2. Loosen locknut B and turn switch A until it does not contact the pedal arm.
3. Loosen locknut D and turn rod C to adjust the height.
4. Adjust the pedal free play and tighten locknut D. (Refer to below.)
5. Turn switch A until it contacts the pedal arm; then turn an additional 1/2 turn.
6. Tighten locknut B.

Tightening torque:

13.8–17.6 N·m {140–180 kgf·cm, 122–156 in·lbf}

7. Connect the stoplight switch connector.

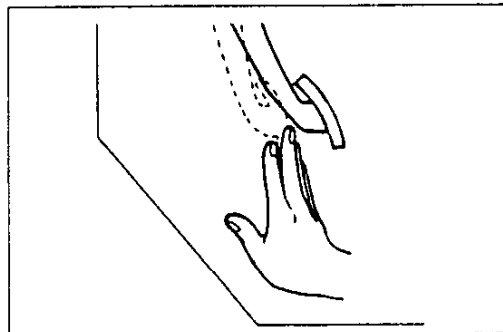

37U0PX-013

Pedal play inspection

1. Depress the pedal a few times to eliminate the vacuum in the system.
2. Lightly depress the pedal by hand until resistance is felt and check the free play.

Free play: 3–8mm {0.12–0.31 in}

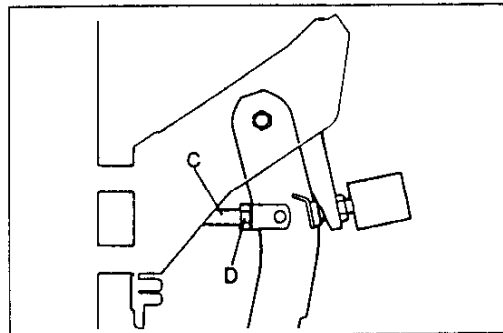

37U0PX-014

Pedal play adjustment

1. Loosen locknut D and turn rod C to adjust the free play

Free play: 3–8mm {0.12–0.31 in}

2. Tighten locknut D.

Tightening torque:

24–34 N·m {2.4–3.5 kgf·m, 17–25 ft·lbf}

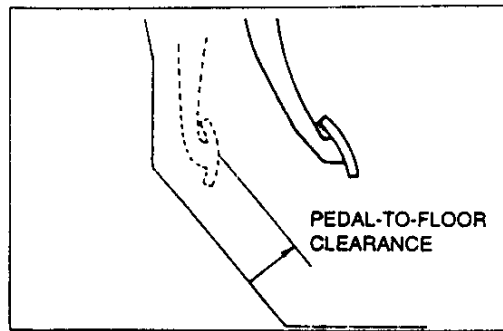

37U0PX-015

Pedal-to-floor clearance

1. Check if the distance from the floor panel to the center of the upper surface of the pedal pad is as specified when the pedal is depressed with a force of **589 N {60 kgf, 132 lbf}**.

Pedal-to-floor clearance: 100 mm {3.94 in} min. (without carpet)

2. If the distance is less than specified, inspect for air in the brake system.

P

CONVENTIONAL BRAKE SYSTEM

Removal / Inspection / Installation

1. Remove the side wall. (Refer to Section S.)
2. Remove the lower panel. (Refer to Section S.)
3. Remove the column cover.
4. Remove in the order shown in the figure.
5. Inspect all parts and repair or replace as necessary
6. Install in the reverse order of removal.
7. After installation, check and if necessary adjust the pedal height and free play.

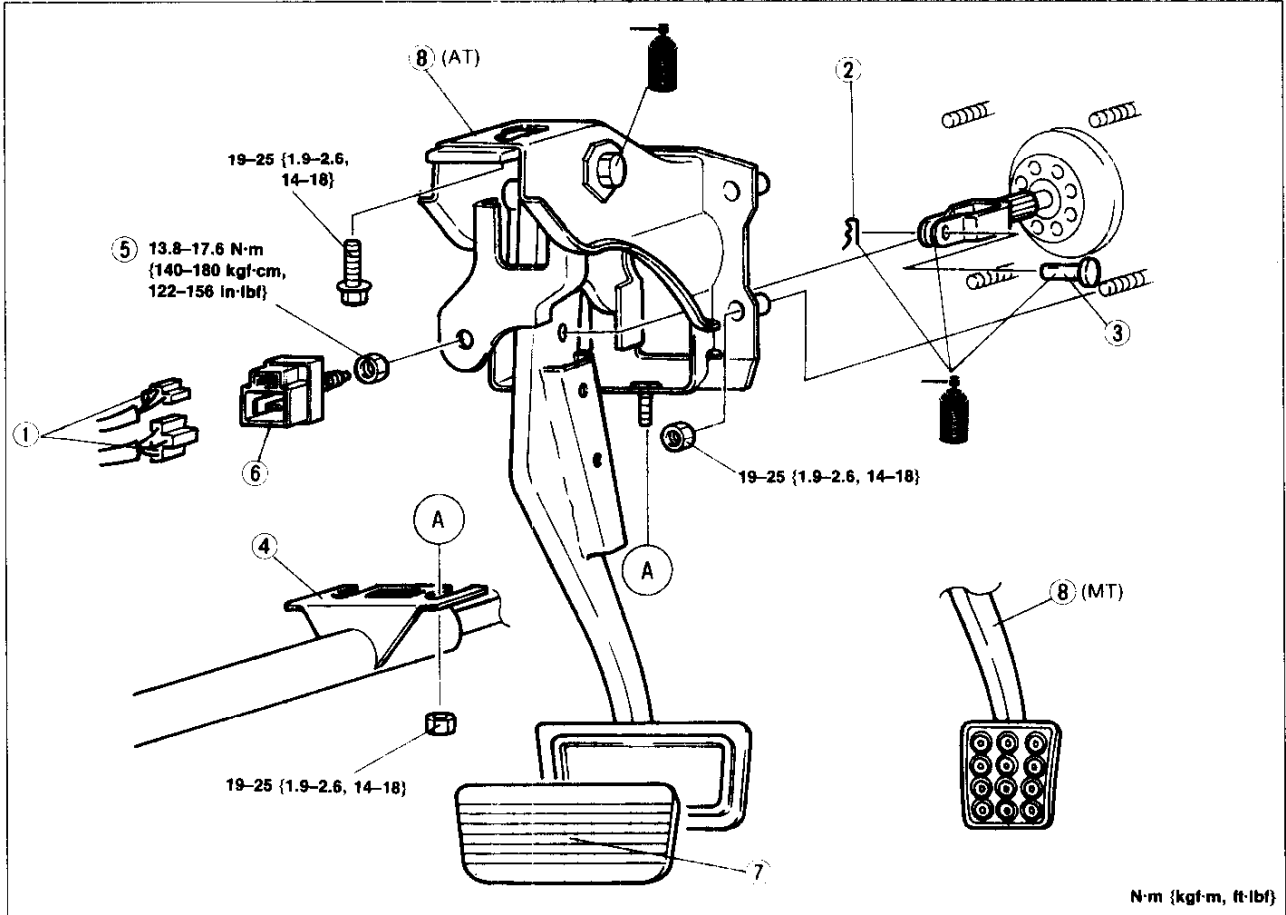

N·m {kgf·m, ft·lbf}

37U0PX-016

- | | |
|--|-----------------------------------|
| 1. Stoplight switch connector | 6. Stoplight switch |
| 2. Spring clip | Inspection below |
| 3. Clevis pin | 7. Pedal pad |
| 4. Steering shaft bracket mounting nut | Inspection for wear and damage |
| Service Section N | 8. Brake pedal |
| 5. Nut | Inspection for bending and damage |

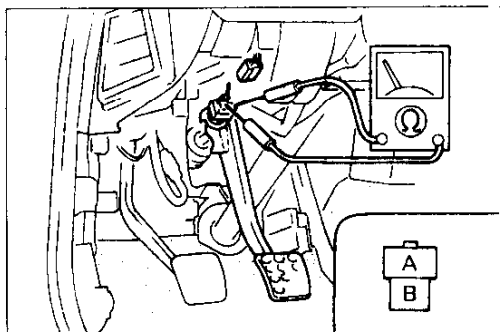

29U0PX 0-11

Inspection Stoplight switch

1. Disconnect the stoplight switch connector.
2. Connect an ohmmeter between terminals of the stoplight switch.
3. Confirm continuity between the terminals when the brake pedal is depressed.

MASTER CYLINDER

Removal / Installation

1. Remove in the order shown in the figure, referring to **Removal Note**.
2. Install in the reverse order of removal, referring to **Installation Note**.
3. After installation, perform the following.
 - (1) Add fluid and bleed the air. (Refer to page P-7.)
 - (2) Check for fluid leakage. (Refer to page P-8.)

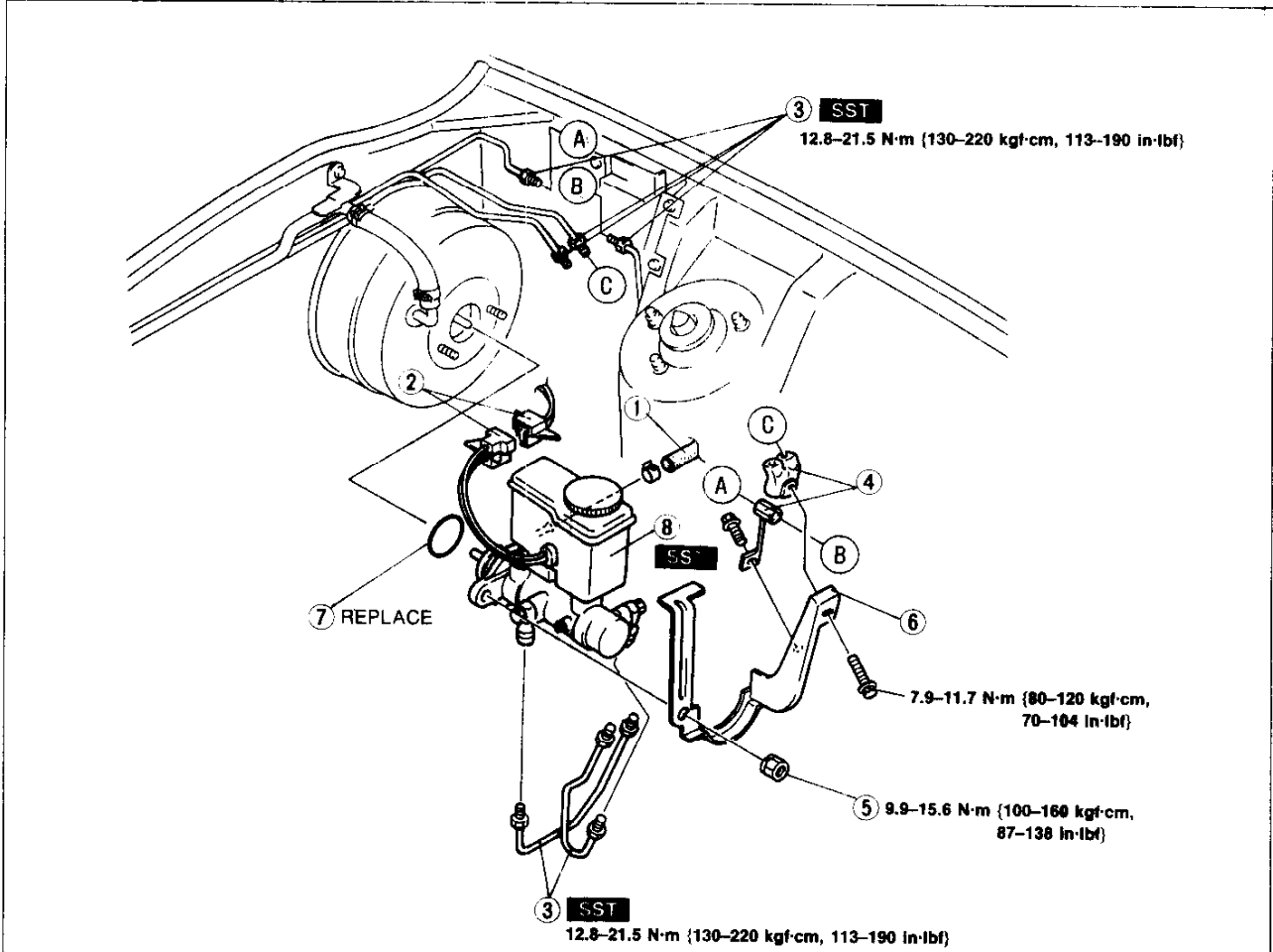

37U0PX-017

- | | |
|---------------------------------------|-----------------------------------|
| 1. Hose (MT) | 6. Bracket |
| 2. Brake fluid level sensor connector | 7. O-ring |
| 3. Brake pipe | 8. Master cylinder |
| Removal Note below | Disassembly / Inspection / |
| Installation Note page P-14 | Assembly page P-15 |
| 4. Pipe joint and bracket | Installation Note page P-12 |
| 5. Nut | |

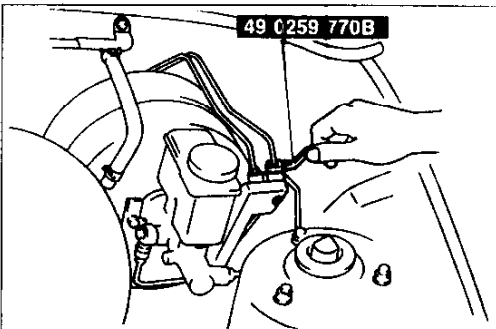

29U0PX-020

Removal note

Brake pipe

Loosen the brake pipe at the master cylinder by using the **SST**.

Caution

- Do not allow the brake fluid to get on painted surfaces. If it does, wipe it off immediately.

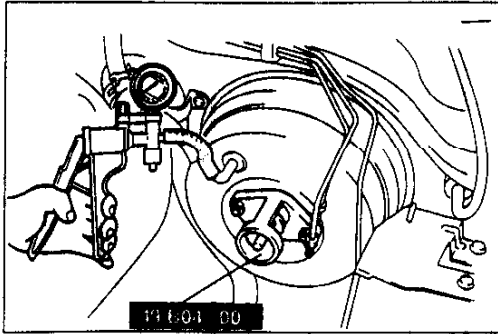

37U0PX-018

Installation note

Master cylinder

Piston to push rod clearance

1. Turn the nut of the **SST** clockwise to fully retract the gauge rod. Attach the **SST** to the power brake unit.

Caution

- Install with the gauge rod fully retracted.

Tightening torque:

9.9–15.6 N·m {100–160 kgf·cm, 87–138 in·lbf}

2. Apply **66.7 kPa {500 mmHg, 19.7 inHg}** vacuum by using a vacuum pump.

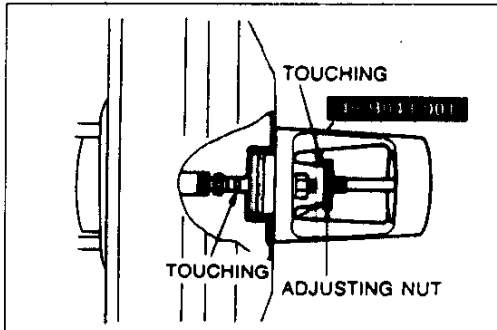

29U0PX-025

3. Turn the adjusting nut of the **SST** counterclockwise until the gauge rod just contacts the end of the master cylinder push rod.

Push lightly on the end of the gauge rod to be sure it is seated. Verify that there is no gap between the adjusting nut and the **SST** body.

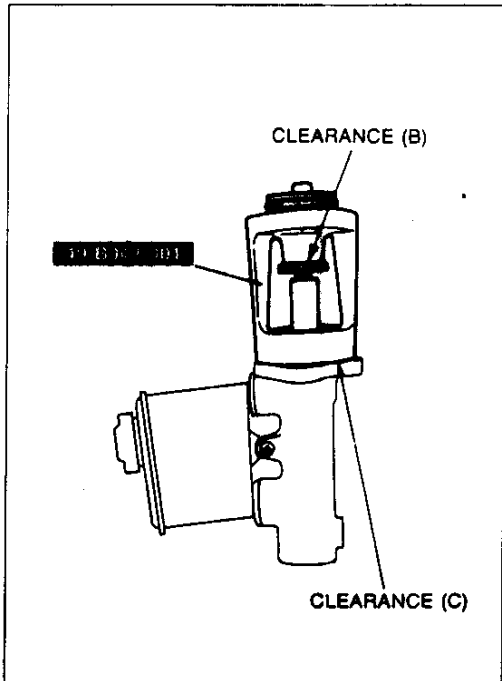

37U0PX-019

4. Remove the **SST** from the power brake unit without disturbing the adjusting nut. Set the **SST** onto the master cylinder as shown in the figure.

Caution

- When pushing use only enough pressure to bottom the rod in the piston. If too much pressure is applied a false reading will occur.

5. Push lightly on the end of the **SST** gauge rod to be sure it is bottomed in the master cylinder piston, and note any clearance between the **SST** body and the adjusting nut (clearance B) or between the body and the master cylinder (clearance C). Adjust the push rod as necessary as outlined in "Adjustment" on the next page.

Measurement	Push rod
Clearance at (B)	Too short
Clearance at (C)	Too long
No clearance at (B) or (C)	OK

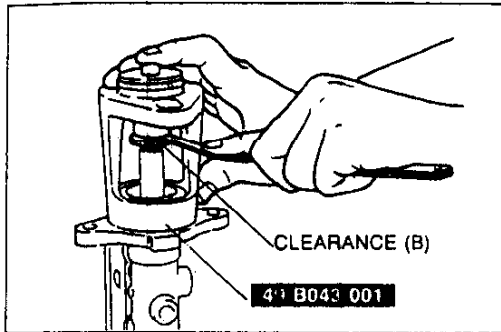

29U0PX-027

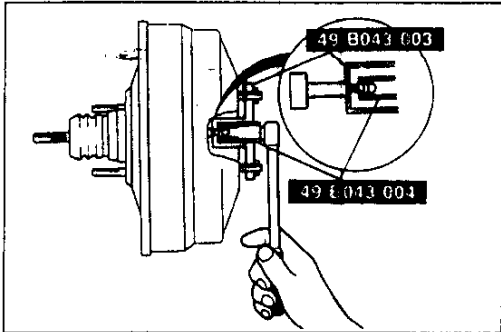

29U0PX-028

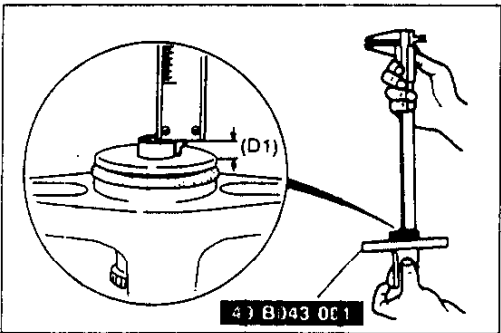

29U0PX-029

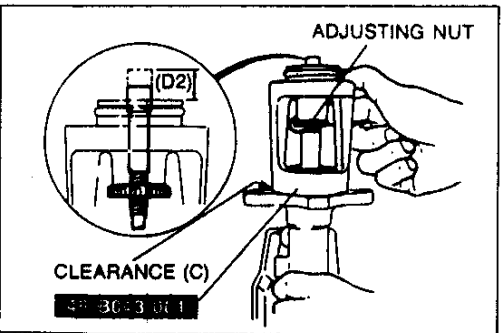

29U0PX-030

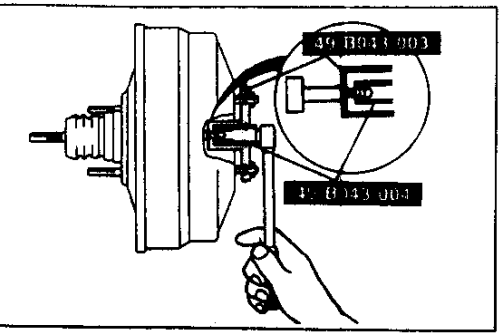

29U0PX-31

Adjustment

Note

- The threads of the push rod are specially designed so that the bolt becomes harder to turn past a certain point to prevent loosening of the bolt. Turn the bolt only within this range when adjusting.

Clearance at B

1. Push lightly on the end of the **SST** gauge rod, and measure the clearance between the adjusting nut and the **SST** body.
2. Using the **SSTs**, turn the nut to lengthen the master cylinder push rod an amount equal to the clearance measured at B.

Clearance at C

1. Measure and record height D1 of the gauge rod.
2. Turn the adjusting nut until the **SST** body sets squarely on the master cylinder. (Turn only enough for the body to touch.)
3. Measure and record height D2 of the gauge rod.
4. Subtract D1 from D2; then using the **SSTs**, turn the nut to shorten the master cylinder push rod an amount equal to the difference.

P

CONVENTIONAL BRAKE SYSTEM

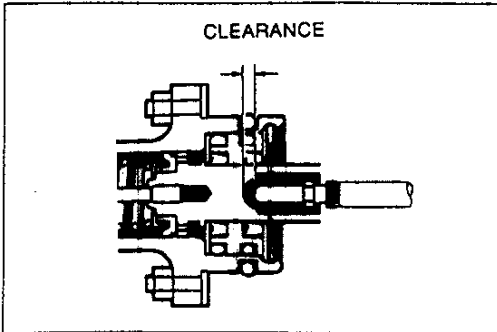

37U0PX-020

Note

- By making the above adjustment, the clearance between the push rod and piston (after installation of the master cylinder to the power brake unit) will be as shown in the table below.

Vacuum applied to unit	Push rod-to-piston clearance
Approx. 66.7 kPa {500 mmHg, 19.7 inHg}	0.1–0.4 mm {0.004–0.016 in}

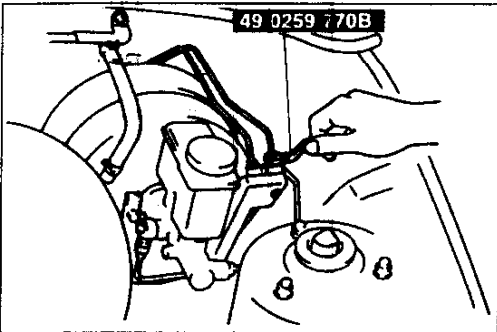

37U0PX-021

Brake pipe

Tighten the brake pipe flare nut by using the **SST**.

Tightening torque:

12.8–21.5 N·m {130–220 kgf·cm, 113–190 in·lbf}

Disassembly / Inspection / Assembly

Caution

- Secure the master cylinder flange in a vise when necessary.
- Replace the piston assembly, if necessary.
- Replace the master cylinder assembly if the master cylinder body is damaged.

1. Disassemble in the order shown in the figure.
2. Inspect all parts and repair or replace as necessary.
3. Assemble in the reverse order of disassembly, referring to **Assembly Note**.

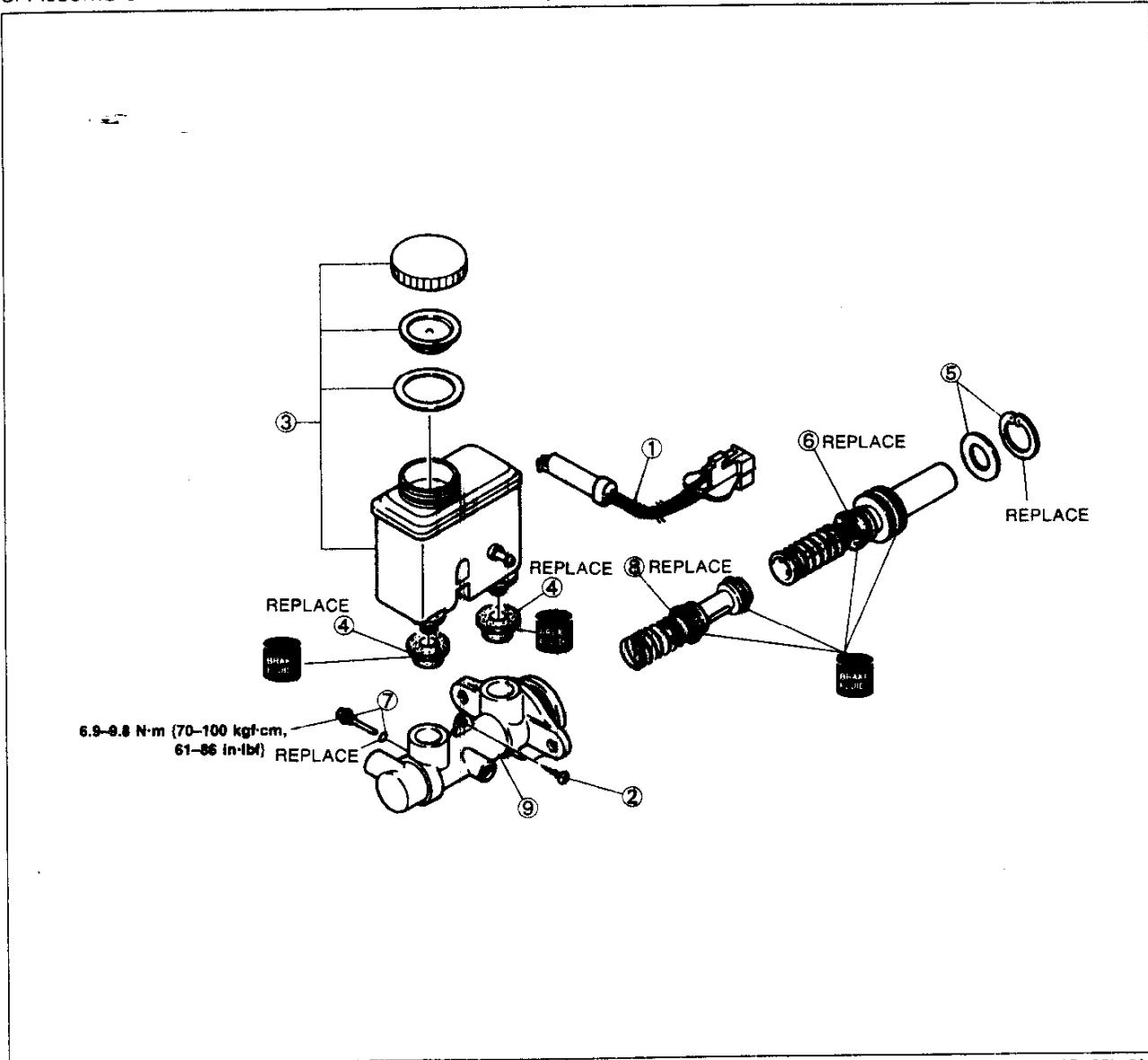

37U0PX-022

- | | |
|--|--|
| <ol style="list-style-type: none"> 1. Brake fluid level sensor
Inspection page P-16 2. Screw 3. Reservoir assembly
Inspect for damage and deformation 4. Bushings 5. Snap ring and spacer 6. Primary piston assembly
Inspect for abnormal wear, rust, and damage | <ol style="list-style-type: none"> 7. Stop pin and O-ring
Assembly Note page P-16 8. Secondary piston assembly
Inspect for abnormal wear, rust, and damage 9. Master cylinder body
Inspect for damage and wear
Inspect inside of body for corrosion |
|--|--|

CONVENTIONAL BRAKE SYSTEM

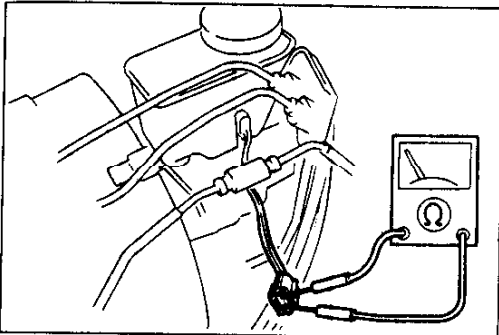

37U0PX-110

Inspection Brake fluid level sensor

1. Disconnect the brake fluid level sensor connector.
2. Check continuity of the brake fluid level sensor.

Fluid level	Continuity
Below MIN	Yes
Above MIN	No

3. If not as specified, replace the brake fluid level sensor.

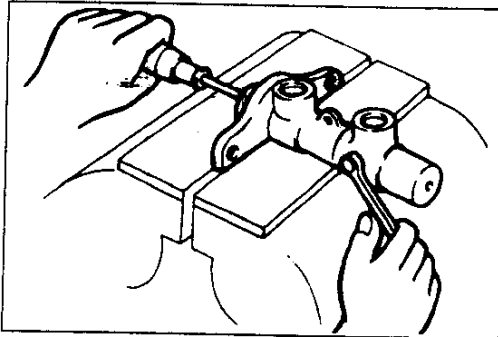

29U0PX-036

Assembly note Stop pin and O-ring

1. Install a new O-ring onto the stop pin.
2. Install the secondary piston assembly with the hole in the piston facing the stop pin.
3. Install and tighten the stop pin.
4. Push and release the piston to verify that it is held by the stop pin.

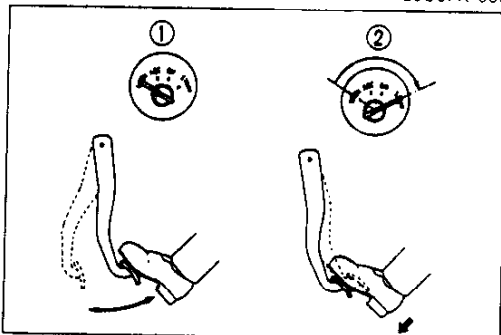

29U0PX-037

POWER BRAKE UNIT Inspection (On-vehicle) Power brake unit function check (Simple method) Step 1

1. With the engine stopped, depress the brake pedal a few times.
2. With the pedal depressed, start the engine.
3. If immediately after the engine starts the pedal moves down slightly, the unit is operating.

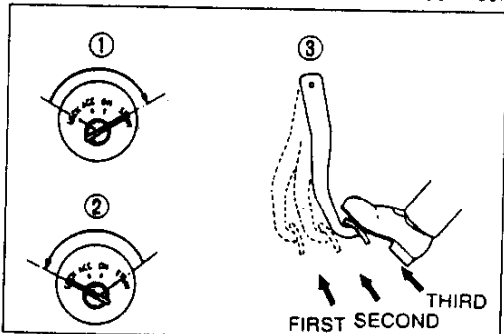

29U0PX-038

Step 2

- 1 Start the engine.
- 2 Stop the engine after it has run for **1 or 2 minutes**.
- 3 Depress the pedal with the usual force.
4. If the first pedal stroke is long and becomes shorter with subsequent strokes, the unit is operating.
5. If a problem is found, inspect for damage of the check valve or vacuum hose and examine the installation. Repair if necessary, and inspect it once again.

Step 3

1. Start the engine.
2. Depress the pedal with the usual force.
3. Stop the engine with the pedal held depressed.
4. Hold the pedal down for **about 30 seconds**.
5. If the pedal height does not change, the unit is operating.
6. If there is a problem, inspect for damage to the check valve or vacuum hose, and inspect the hose connections. Repair if necessary, and inspect once again.

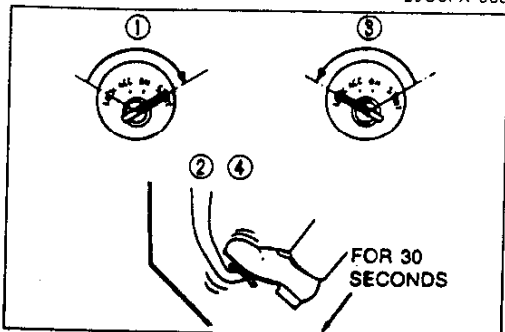

29U0PX-039

If the nature of the problem is still not clear after the three steps above, follow the more detailed check described in "Method using testers". (Refer to page P-17).

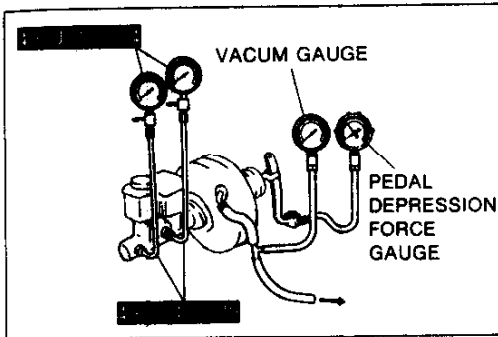

37U0PX-023

(Method using testers)

1. Connect the **SST** or equivalent, vacuum gauge, and pedal depression force gauge as shown in the figure.
2. After bleeding the air from the **SST**, conduct the test as described in the steps below.

Note

- Use commercially available vacuum gauge and pedal depression force gauge.

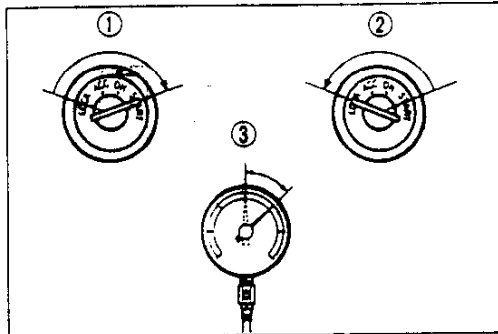

37U0PX-024

a) Checking for vacuum loss Unloaded condition

1. Start the engine.
2. Stop the engine when the vacuum gauge reading reaches **66.7 kPa {500 mmHg, 19.7 inHg}**.
3. Observe the vacuum gauge for 15 seconds. If the gauge shows **63.4–66.7 kPa {475–500 mmHg, 18.7–19.7 inHg}**, the unit is operating.

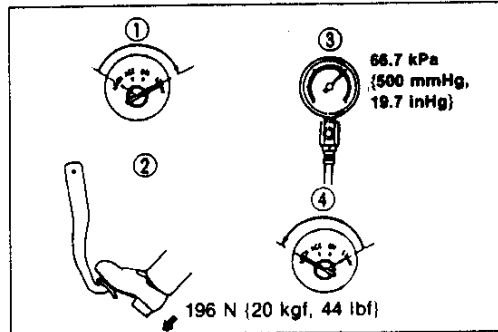

37U0PX-025

Loaded condition

1. Start the engine.
2. Depress the brake pedal with a force of **196 N {20 kgf, 44 lbf}**.
3. With the brake pedal depressed, stop the engine when the vacuum gauge reading reaches **66.7 kPa {500 mmHg, 19.7 inHg}**.
4. Observe the vacuum gauge for **15 seconds**. If the gauge shows **63.4–66.7 kPa {475–500 mmHg, 18.7–19.7 inHg}**, the unit operating.

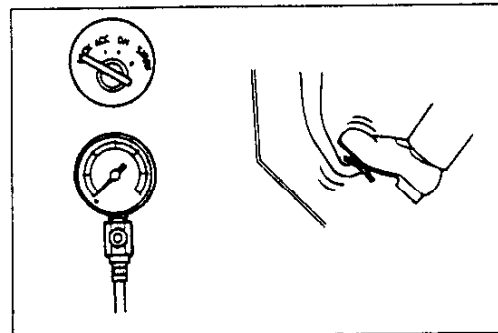

37U0PX-026

b) Checking for hydraulic pressure

1. If, with the engine stopped (vacuum **0 kPa {0 mmHg, 0 inHg}**), the fluid pressure is within specification, the unit is operating.

Pedal force	Fluid pressure kPa {kgf/cm ² , psi}
196 N {20 kgf, 44 lbf}	590 {6, 85} min.

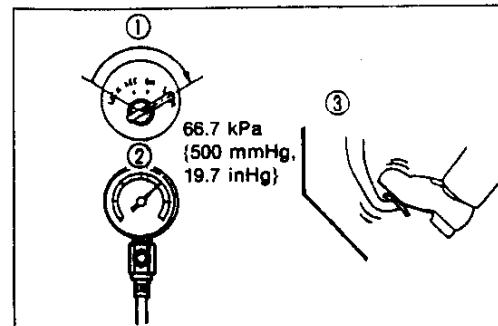

37U0PX-027

2. Start the engine. Depress the brake pedal when the vacuum reaches **66.7 kPa {500 mmHg, 19.7 inHg}**. If the fluid pressure is within specification, the unit is operating.

Pedal force	Fluid pressure kPa {kgf/cm ² , psi}
196 N {20 kgf, 44 lbf}	7750 {79, 1120} min.

Removal / Installation

1. Remove in the order shown in the figure, referring to **Removal Note**.
2. Install in the reverse order of removal, referring to **Installation Note**.
3. After installation, perform the following.

- (1) Add fluid and bleed the air. (Refer to page P-7.)
- (2) Check and adjust the brake pedal height. (Refer to page P-9.)
- (3) Check for fluid leakage. (Refer to page P-8.)

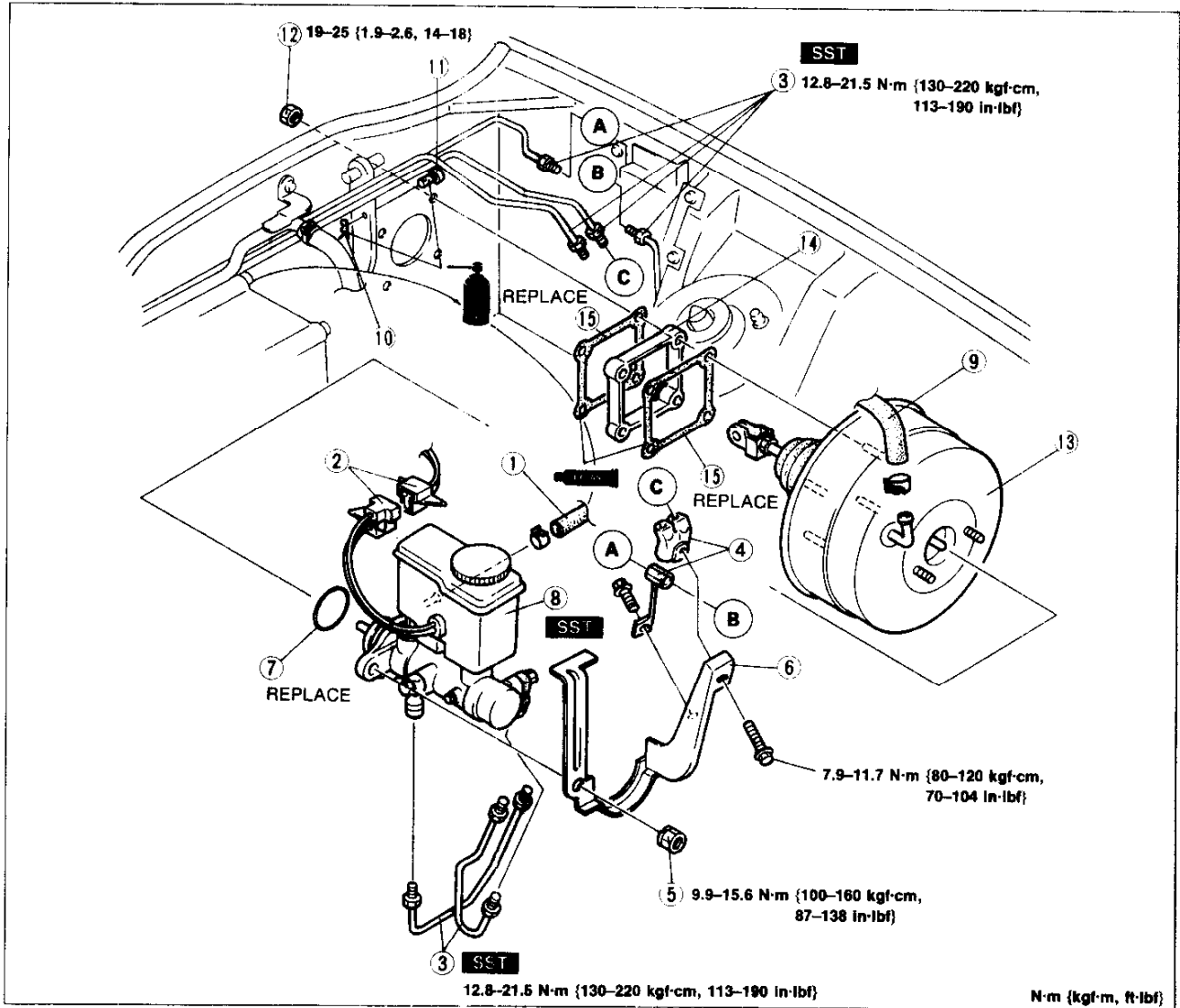

- 1. Hose (MT)
- 2. Brake fluid level sensor connector
- 3. Brake pipe
Removal Note page P-11
Installation Note page P-14
- 4. Pipe joint and bracket
- 5. Nut
- 6. Bracket
- 7. O-ring
- 8. Master cylinder
Removal / Installation page P-11
Disassembly / Inspection /
Assembly page P-15

- 9. Vacuum hose
Inspection page P- 8
- 10. Spring clip
- 11. Clevis pin
- 12. Nut
- 13. Power brake unit
Inspection page P-16
- 14. Spacer
- 15. Gasket

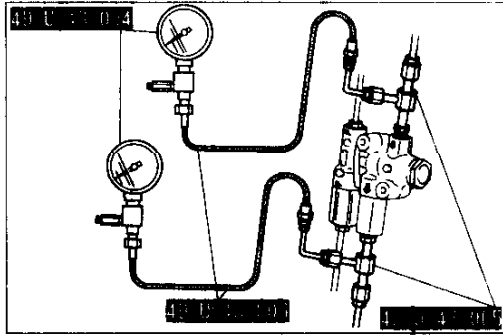

37U0PX-029

PROPORTIONING BYPASS VALVE

Inspection

1. Connect the **SST** or equivalent to the inlet and outlet pipes to the rear brake system.
2. After bleeding the air from the **SST**, measure the fluid pressure from the master cylinder and to the rear brakes.

Specification:

	FLUID PRESSURE KPa {kgf/cm ² , psi}	REAR BRAKE PRESSURE
MASTER CYLINDER PRESSURE	A = 3,920 {40,570}	A' = 3,630-4,210 {37-43, 530-610}
	B = 5,880 {60,850}	B' = 4,320-5,090 {44-52, 626-739}

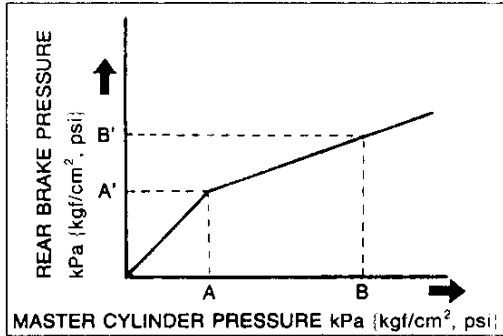

37U0PX-030

3. If not as specified, replace the proportioning bypass valve assembly.

Caution

- **After inspection:**
Add brake fluid and bleed the air.
(Refer to page P-7.)
- **Check the brake lines for fluid leakage.**
(Refer to page P-8.)

Replacement

1. Remove in the order shown in the figure, referring to **Removal Note**.
2. Install in the reverse order of removal, referring to **Installation Note**.
3. After installation, perform the following.
 - (1) Add fluid and bleed the air. (Refer to page P-7.)
 - (2) Check for fluid leakage. (Refer to page P-8.)

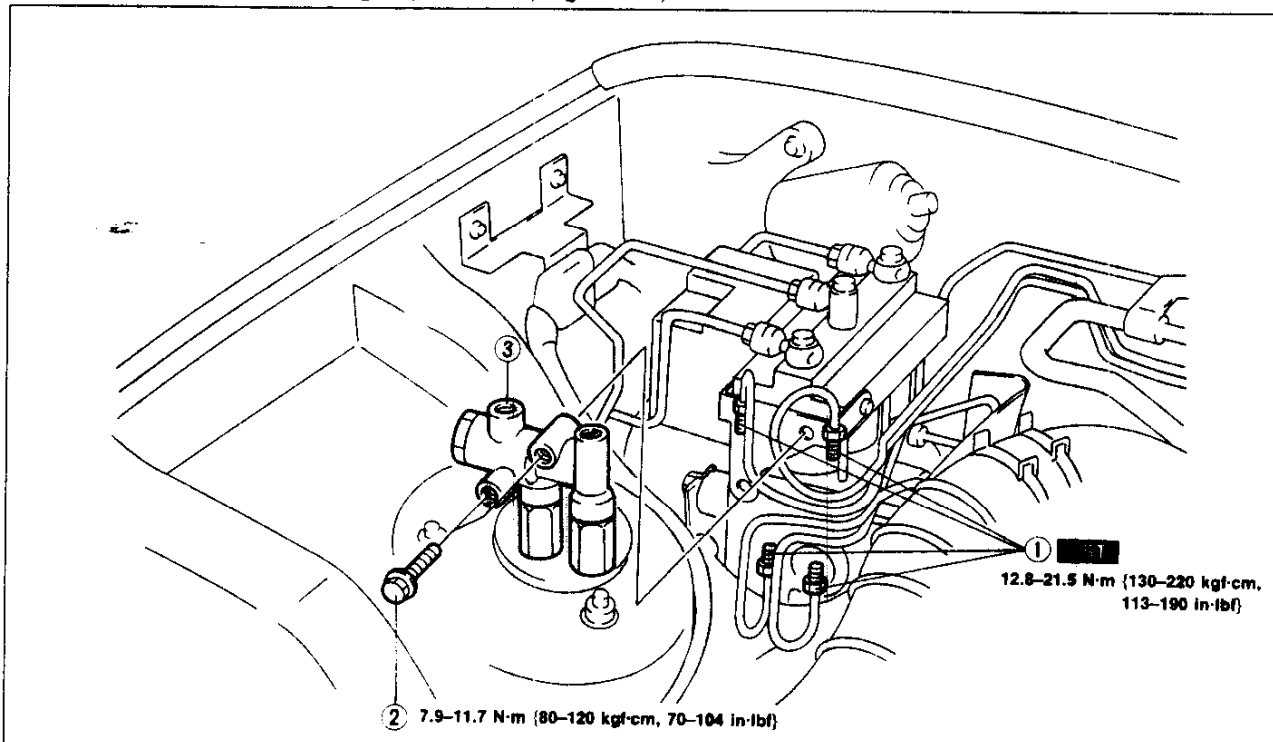

37U0PX-031

- | | | |
|-------------------------|-------|-------------------------------|
| 1. Brake pipe | | 2. Bolt |
| Removal Note | below | 3. Proportioning bypass valve |
| Installation Note | below | Inspection |
| | | page P-19 |

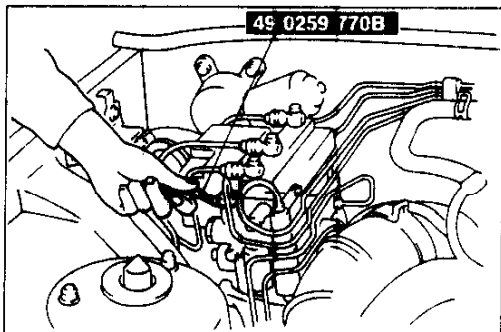

37U0PX-032

Removal / Installation note
Brake pipe

Loosen and tighten the brake pipes by using the **SST**.

Tightening torque:
12.8-21.5 N·m {130-220 kgf·cm, 113-190 in·lbf}

FRONT BRAKE (DISC)

Inspection (on-vehicle)
Disc pad

1. Jack up the front of the vehicle and support it on safety stands.
2. Remove the wheels.
3. Sight through the caliper inspection hole and inspect the remaining thickness of the pads.

Thickness: 1.0mm {0.04 in} min.

4. Replace the pads as a set (right and left wheels) if either is at or less than the minimum thickness.

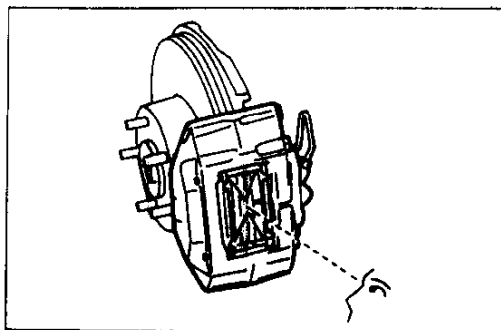

37U0PX-033

Removal / Inspection / Installation

1. Remove in the order shown in the figure, referring to **Removal Note**.

Caution

- Do not loosen or remove the caliper bridge bolts.

2. Inspect all parts and repair or replace as necessary

3. Install in the reverse order of removal, referring to **Installation Note**.

4. After installation, perform the following.

(1) Add fluid and bleed the air. (Refer to page P-7.)

(2) Check for fluid leakage. (Refer to page P-8.)

(3) Depress the pedal a few times, then verify that the brakes do not drag while rotating the wheels by hand.

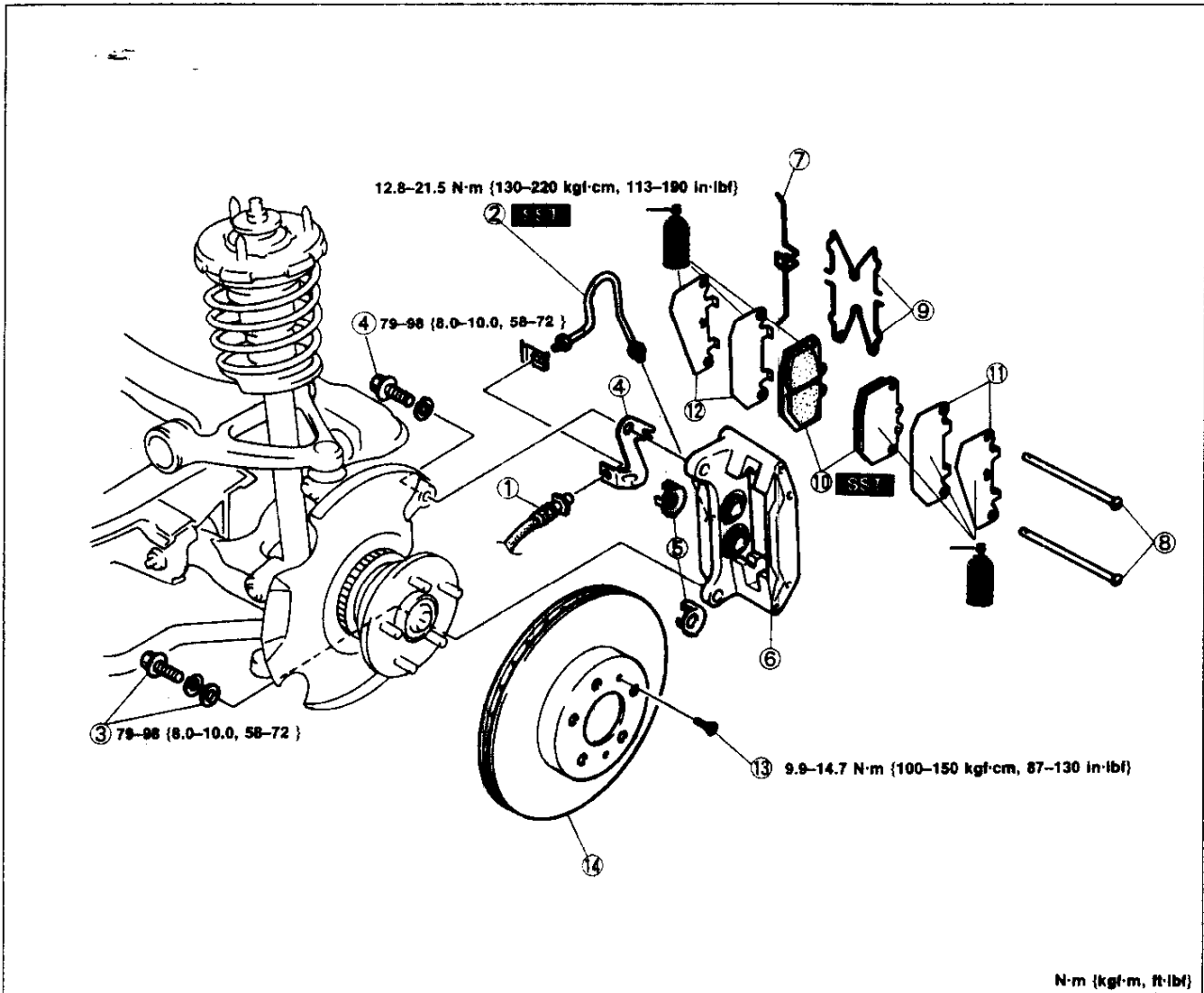

N·m (kgf·m, ft·lbf)

37U0PX-034

1. Brake hose
Inspect for damage and cracks
2. Brake pipe
Removal Note
..... page P-22
Installation Note
..... page P-22
3. Bolt, spacer
4. Bolt, brake pipe bracket
5. Guard plate

6. Caliper
Removal Note
..... page P-22
Disassembly / Inspection /
Assembly page P-25
7. M-spring
8. Pad pin
9. M-clip
10. Disc pad
Inspection page P-20
Installation Note
..... page P-22

11. Outer shim
Installation Note
..... page P-22
12. Inner shim
Installation Note
..... page P-22
13. Screw
14. Disc plate
Inspection page P-23

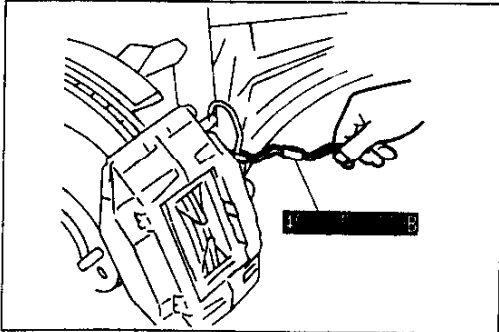

37U0PX-035

Removal note
Brake pipe

Remove the brake pipe by using the **SST**.

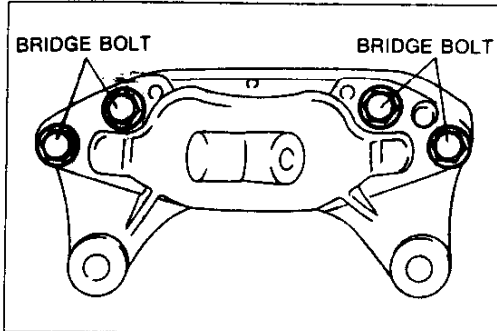

37U0PX-111

Caliper**Caution**

- Do not loosen the caliper bridge bolts.

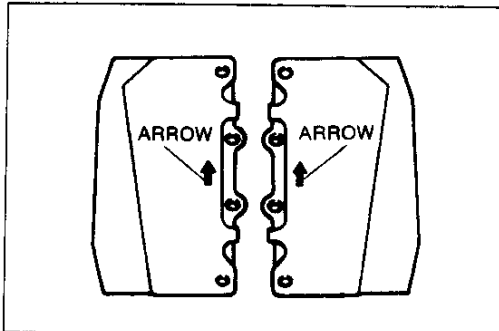

37U0PX-036

Installation note**Outer shim, inner shim**

Align the arrow to the disc plate rotation and install the shims.

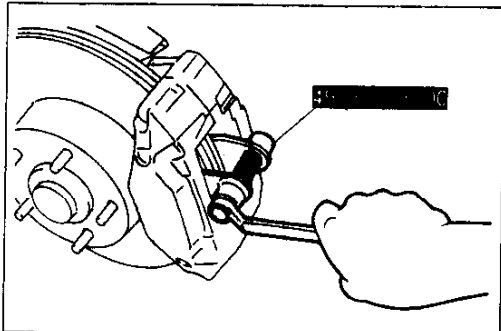

37U0PX-037

Disc pad

1. Clean up the piston.
2. Push the piston inward by using the **SST**.
3. Install the disc pads.

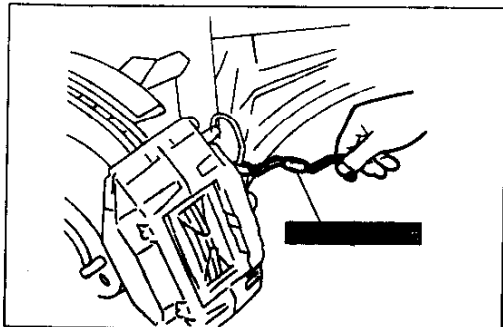

37U0PX-038

Brake pipe

Install the brake pipe by using the **SST**.

Tightening torque:

12.8-21.5 N·m {130-220kgf·cm, 113-190in·lbf}

DISC PAD (FRONT)

Replacement

1. Remove in the order shown in the figure.
2. Install in the reverse order of removal, referring to **Installation Note**.

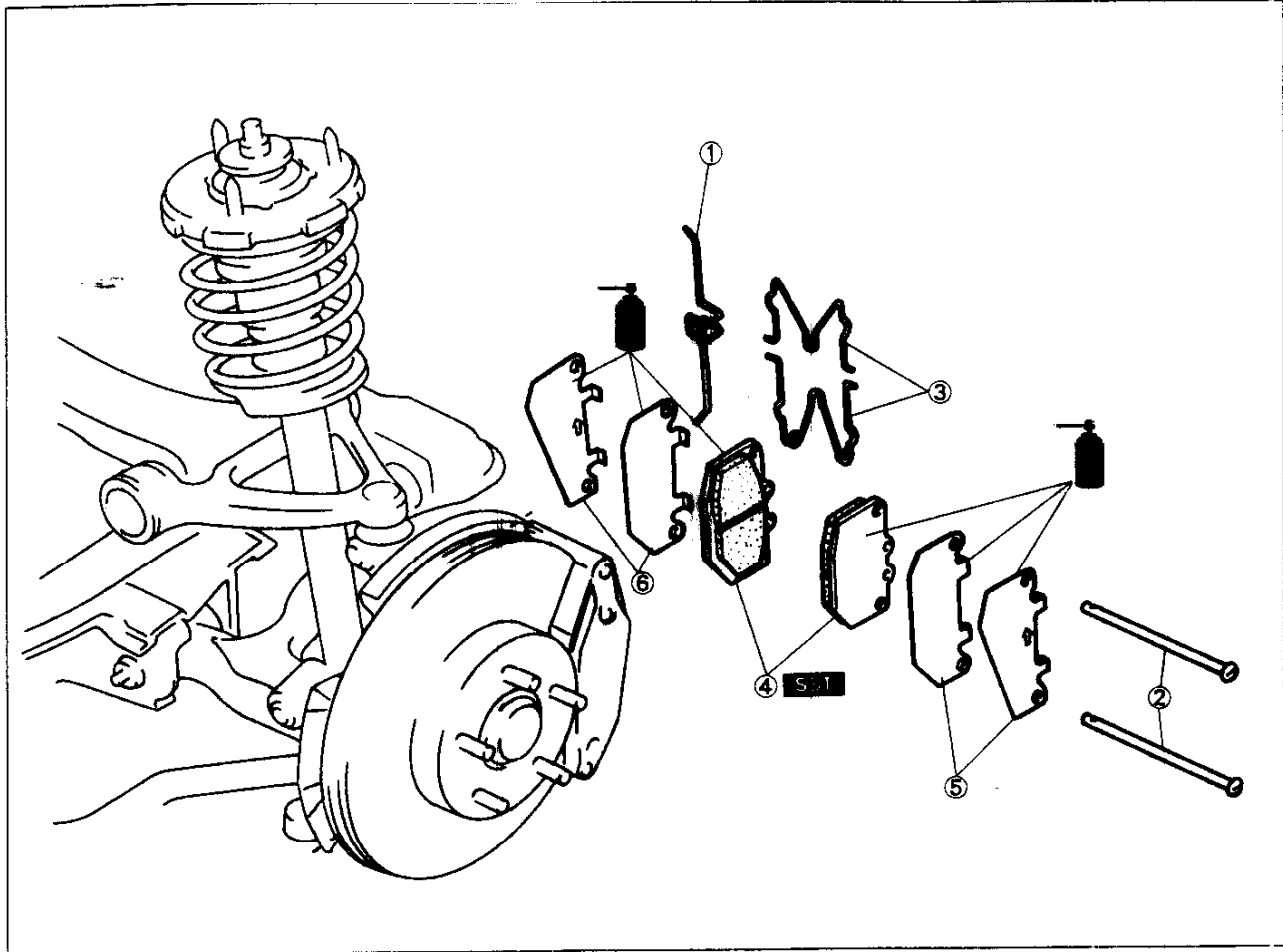

37U0PX-009

1. M-clip
2. Pad pin
3. M-spring

4. Disc pad
Installation Note
..... Page P-22
5. Outer shim
Installation Note
..... page P-22

6. Inner shim
Installation Note
..... page P-22

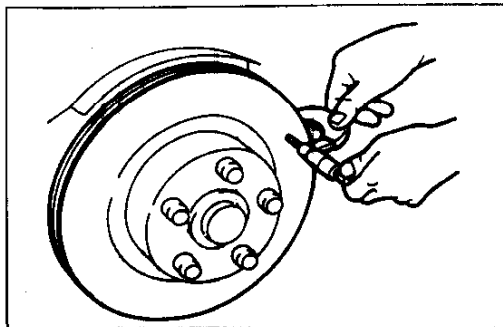

37U0PX-040

DISC PLATE (FRONT)

Inspection
Disc plate thickness

1. Measure the thickness of the disc plate.

Standard: 22.0 mm {0.87 in}
Minimum: 20.0 mm {0.79 in}

2. If the thickness is less than minimum, replace the disc plate.

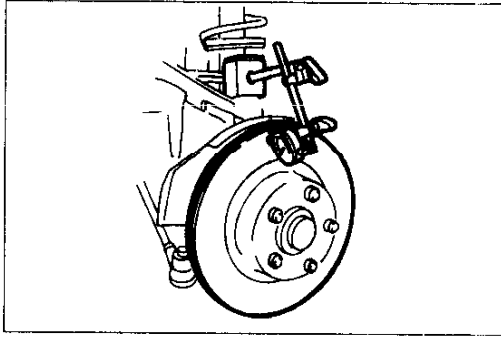

37U0PX-i41

Disc plate runout**Caution**

- **There must be no wheel bearing looseness.**

1. Measure the runout at the outer edge of the contact surface of the disc pad.

Runout: 0.1 mm {0.004 in} max.

2. If the runout exceeds specification, repair or replace the disc plate.

CALIPER (FRONT)

Disassembly / Inspection / Assembly

1. Disassemble in the order shown in the figure, referring to **Disassembly Note**.

Caution

● **Do not loosen or remove the caliper bridge bolts. (Refer to page P-22.)**

2. Inspect all parts and repair or replace as necessary.

3. Assemble in the reverse order of disassembly, referring to **Assembly Note**.

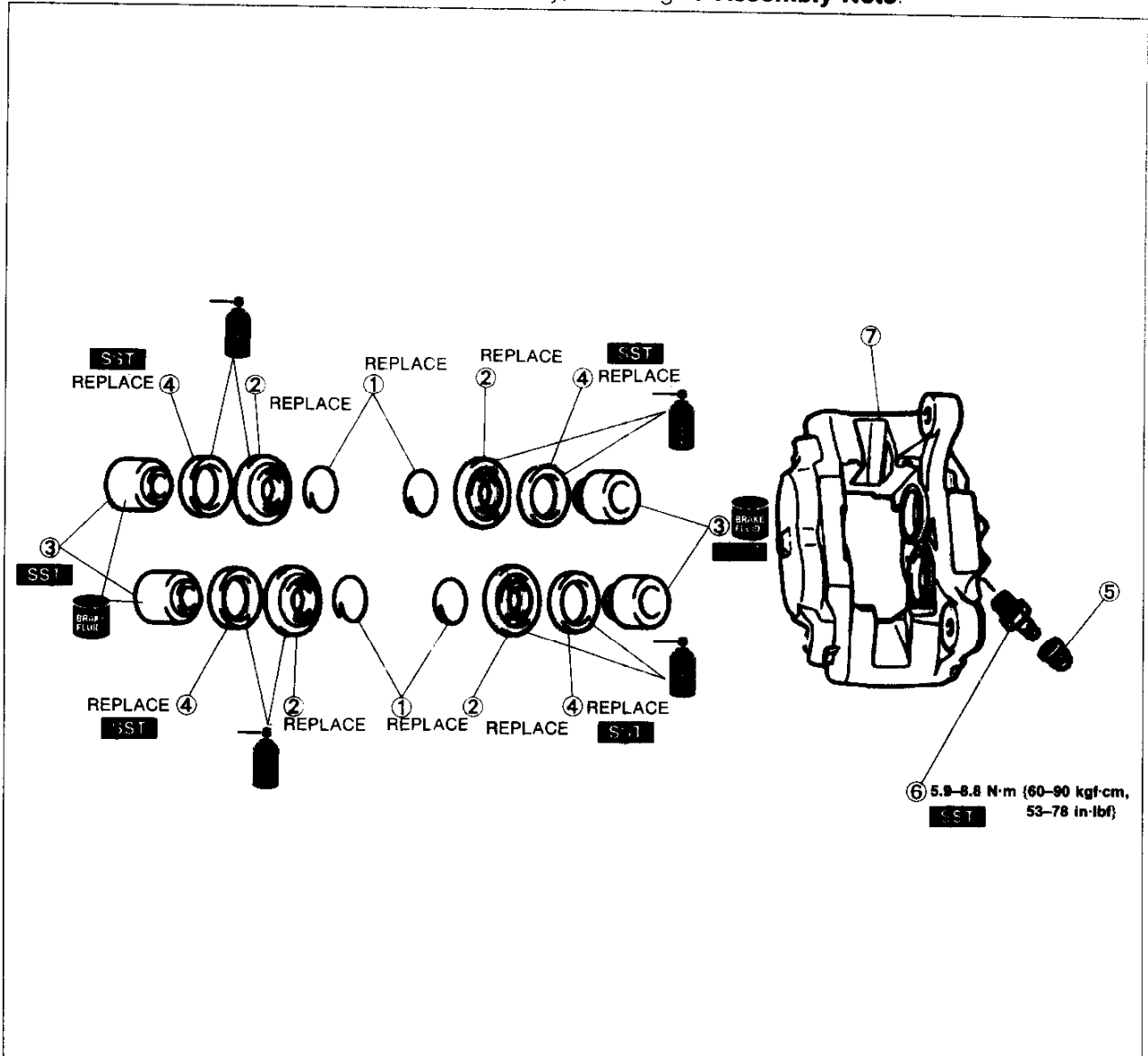

1. Piston ring
2. Dust boot
Inspect for wear and cracks

3. Piston
Disassembly Note
..... page P-26
Inspect for wear and cracks
4. Piston seal
Disassembly Note
..... page P-26

5. Bleeder cap
6. Bleeder screw
Disassembly Note
..... page P-26
Assembly Note
..... page P-26
7. Caliper body
Inspect for damage and wear

37UOPX-042

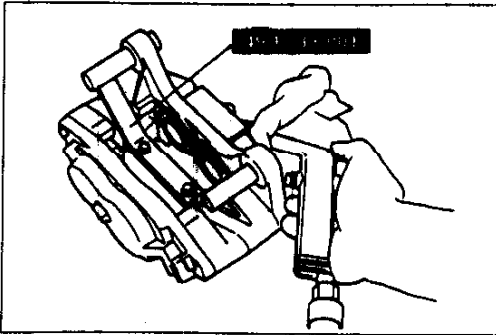

37U0PX-043

Disassembly note

Piston

1. Place the **SST** in the caliper.
2. Blow compressed air through the pipe hole to force the pistons out of the caliper.

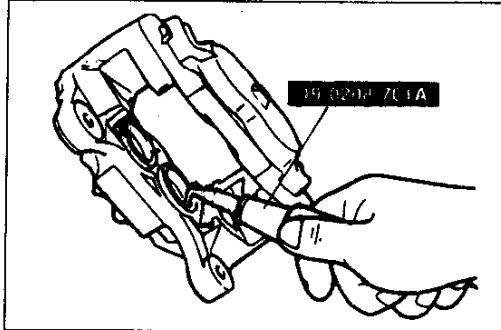

29U0PX-059

Piston seal

Remove the piston seal from the caliper by using the **SST**.

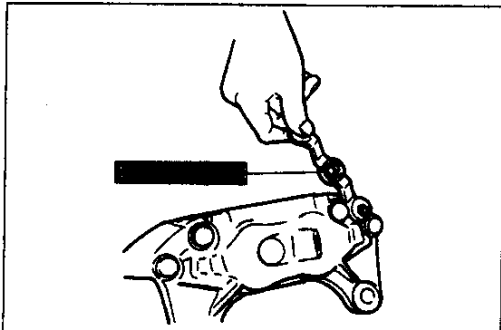

29U0PX-060

Bleeder screw

Loosen the bleeder screw by using the **SST**.

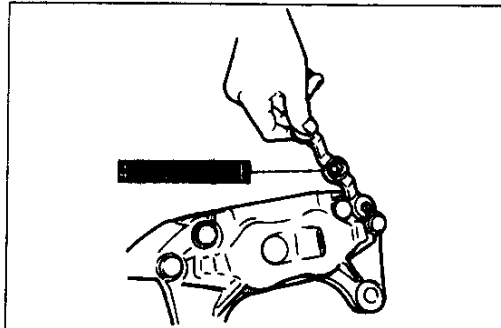

29U0PX-081

Assembly note

Bleeder screw

Tighten the bleeder screw by using the **SST**.

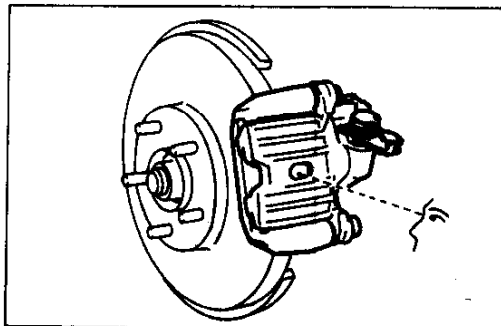

37U0PX-044

REAR BRAKE (DISC)

Inspection (on-vehicle)

Disc pad

1. Jack up the rear of the vehicle and support it on safety stands.
2. Remove the wheel.
3. Sight through the caliper inspection hole and inspect the remaining thickness of the pads.

Thickness: 1.0 mm {0.04 in} min.

4. Replace the pads as a set (right and left wheels) if either is at or less than the minimum thickness.

Removal / Inspection / Installation

1. Remove in the order shown in the figure.
2. Inspect all parts and repair or replace as necessary.
3. Install in the reverse order of removal, referring to **Installation Note**.

Note

● Match the lock pin (L) and guide pin (G) to the L and G marks of the caliper body.

4. After installation, check the following.
 - (1) Add fluid and bleed the air. (Refer to page P-7.)
 - (2) Check for fluid leakage. (Refer to page P-8.)
 - (3) Depress the pedal a few times, then verify that the brakes do not drag while rotating the wheels by hand.

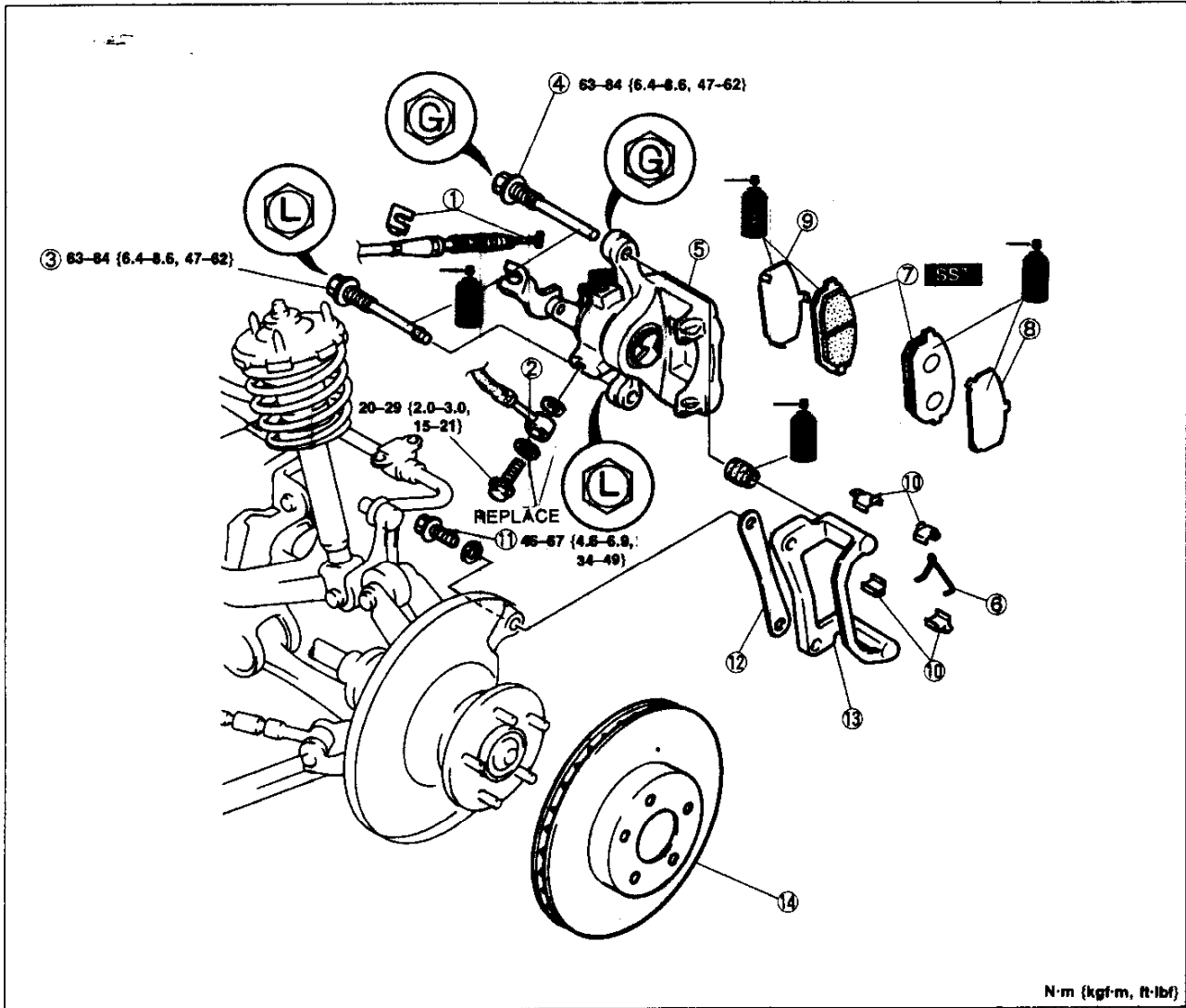

N·m (kgf·m, ft·lbf)

37UOPX-045

- | | | |
|---|---|--|
| <ol style="list-style-type: none"> 1. Clip and rear parking cable 2. Flexible brake hose
Inspect for damage and cracks 3. Lock pin 4. Guide pin 5. Caliper
Disassembly / Inspection /
Assembly page P-30 | <ol style="list-style-type: none"> 6. V-spring 7. Disc pad
Inspection page P-26
Installation Note
..... page P-28 8. Outer shim 9. Inner shim | <ol style="list-style-type: none"> 10. Pad clip 11. Bolt, washer 12. Protector 13. Mounting support 14. Disc plate
Inspection page P-29 |
|---|---|--|

P

CONVENTIONAL BRAKE SYSTEM

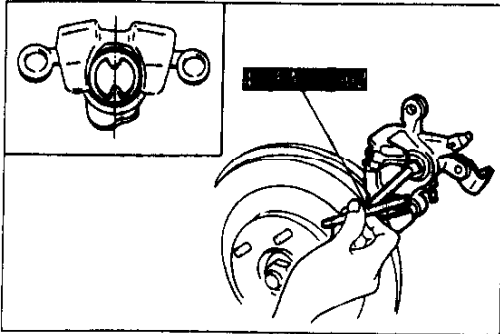

37U0PX-046

Installation note Disc pad

1. Clean up the piston with clean brake fluid.
2. Rotate the piston clockwise by using the **SST**.

Note

- **Align the piston grooves as shown in the illustration.**

3. Install the disc pads.

DISC PAD (REAR)

Replacement

1. Disconnect the rear parking cable from the caliper.
2. Remove in the order shown in the figure.
3. Install in the reverse order of removal, referring to **Installation Note**.

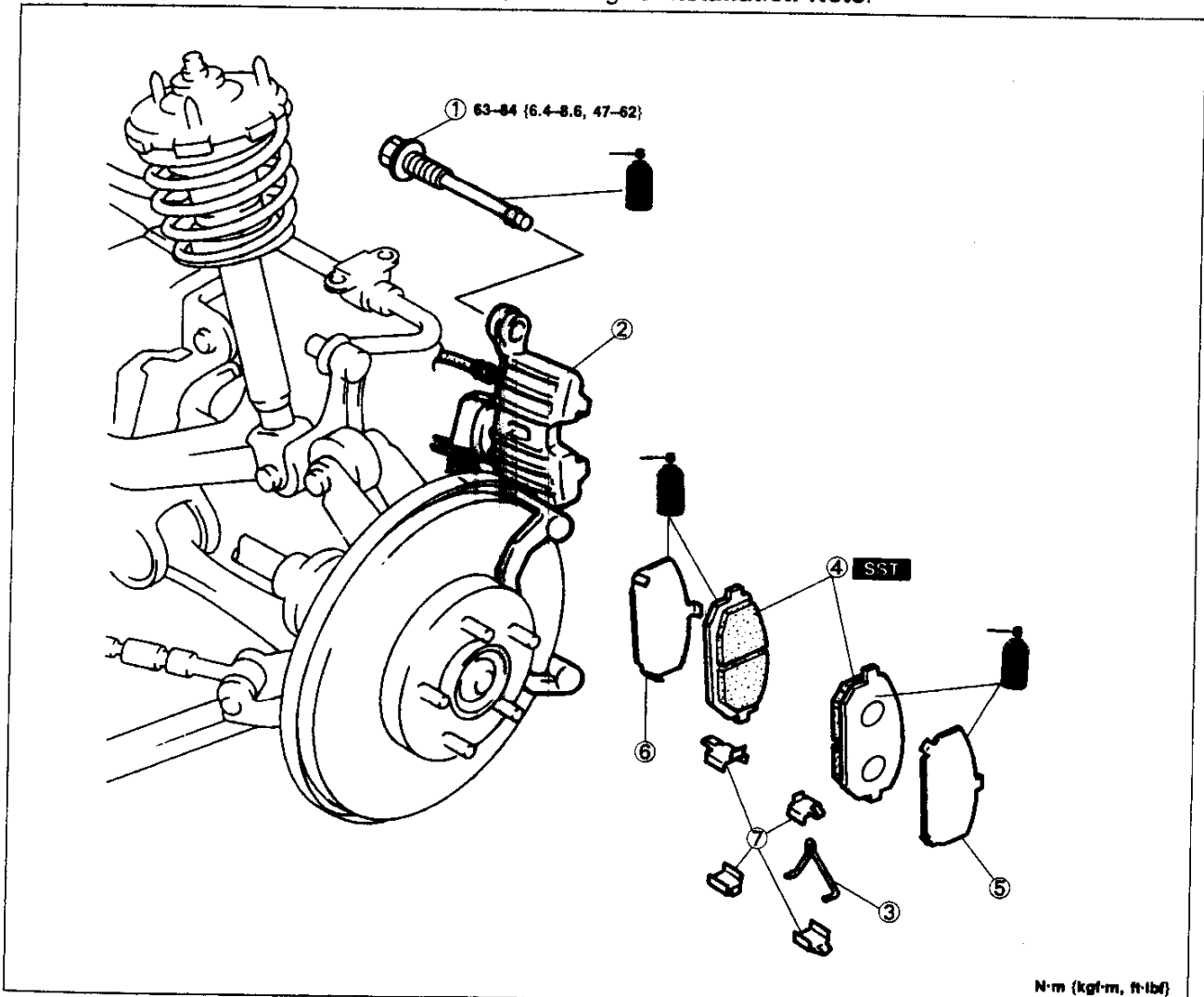

N·m (kgf-m, ft-lbf)

37U0PX-047

1. Lock pin
2. Caliper
3. V-spring
4. Disc pad

Installation Note above

5. Outer shim
6. Inner shim
7. Pad clip

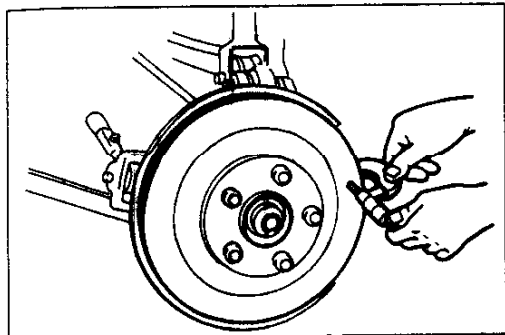

37U0PX-048

DISC PLATE (REAR)

Inspection

Disc plate thickness

1. Measure the thickness of the disc plate.

Standard: 20.0 mm {0.79 in}

Minimum: 18.0 mm {0.71 in}

2. If the thickness is less than minimum, replace the disc plate.

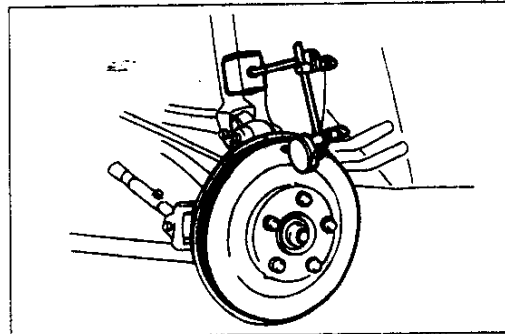

37U0PX-049

Disc plate runout

Caution

- There must be no wheel bearing looseness.

1. Measure the runout at the outer edge of the contact surface of the disc pad.

Runout: 0.1 mm {0.004 in} max.

2. If the runout exceeds specification, repair or replace the disc plate.

CALIPER (REAR)

Disassembly / Inspection / Assembly

1. Disassembly in the order shown in the figure, referring to **Disassembly Note**.
2. Inspect all parts and repair or replace as necessary.
3. Assemble in the reverse order of disassembly, referring to **Assembly Note**.

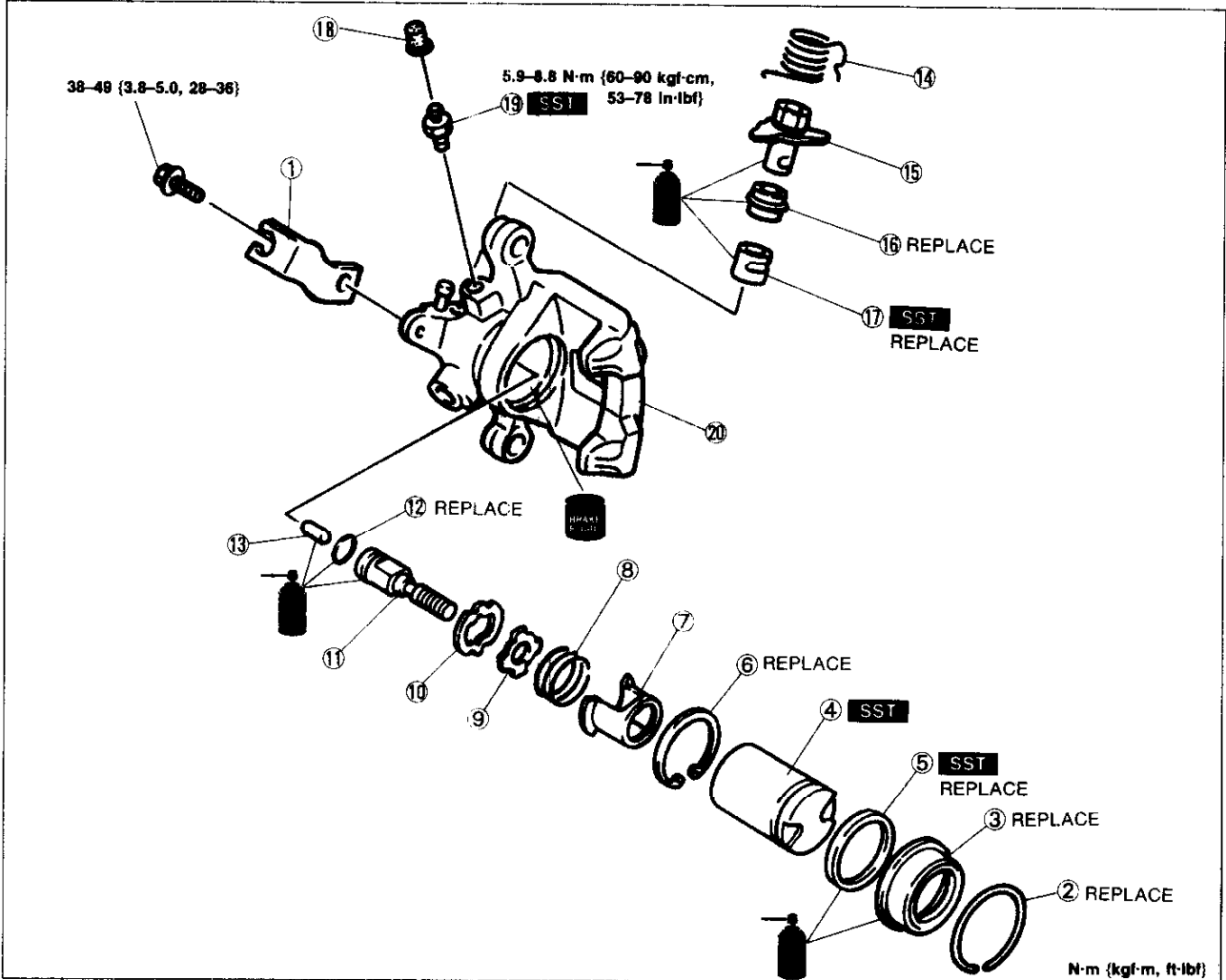

- | | | |
|---|--|--|
| <p>1. Cable bracket</p> <p>2. Retaining ring</p> <p>3. Dust boot</p> <p>4. Piston
Disassembly Note
..... page P-31
Inspect for wear and damage
Assembly Note
..... page P-32</p> <p>5. Piston seal
Disassembly Note
..... page P-31</p> <p>6. Snap ring</p> | <p>7. Case cover</p> <p>8. Spring</p> <p>9. Spring washer</p> <p>10. Stopper</p> <p>11. Adjuster spindle
Inspect for wear and damage</p> <p>12. O-ring</p> <p>13. Connecting link
Inspect for wear and damage</p> <p>14. Lever spring</p> <p>15. Operating lever</p> <p>16. Lever boot</p> | <p>17. Bearing
Disassembly Note
..... page P-31
Assembly Note
..... page P-32</p> <p>18. Bleeder cap</p> <p>19. Bleeder screw
Disassembly Note
..... page P-31
Assembly Note
..... page P-31</p> <p>20. Caliper body
Inspect for wear and damage</p> |
|---|--|--|

37U0PX-050

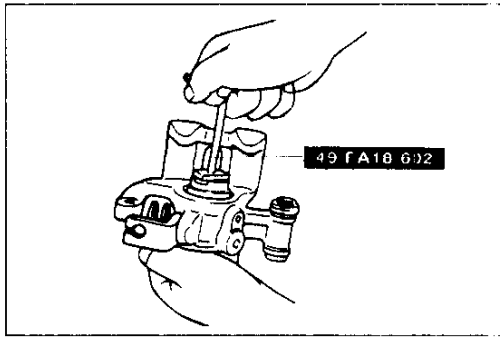

37U0PX-01

Disassembly note
Piston

Remove the piston by using the **SST**.

Note

- Remove the piston by turning the **SST** counter-clockwise.

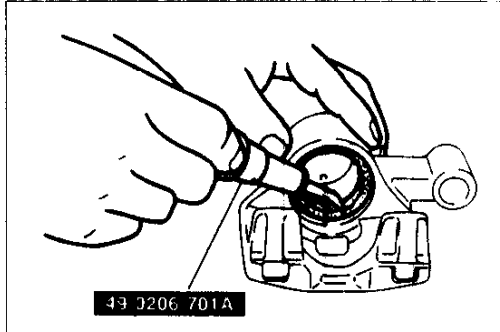

37U0PX-02

Piston seal

Remove the piston seal by using the **SST**.

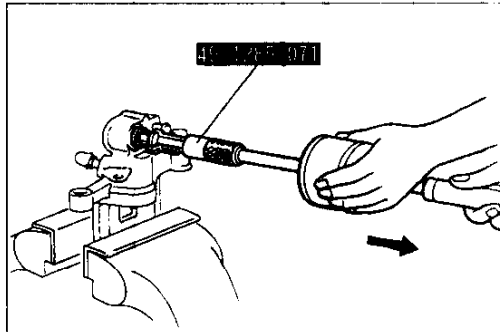

39U0PX-1:7

Bearing

1. Secure the caliper in a vise.

Caution

- Insert a soft, protective material (such as copper plates) in the jaws of the vise.

2. Remove the bearing from the caliper with the **SST**.

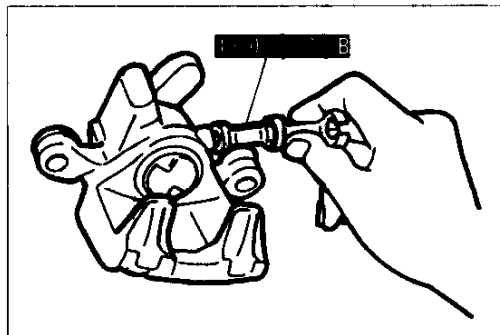

29U0PX-071

Bleeder screw

Loosen the bleeder screw by using the **SST**.

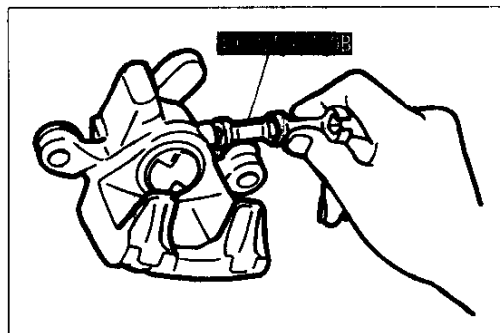

37U0PX-054

Assembly note

Bleeder screw

Tighten the bleeder screw by using the **SST**.

P

CONVENTIONAL BRAKE SYSTEM , PARKING BRAKE SYSTEM

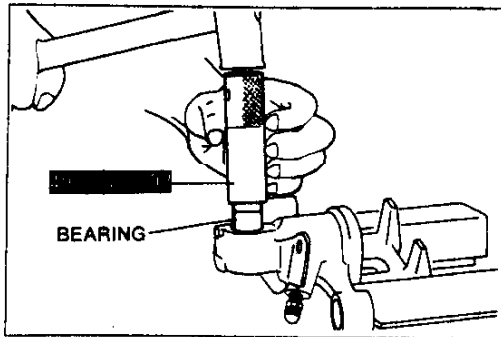

37U0PX-108

Bearing

Press the new bearing into the caliper with the **SST** until the **SST** bottoms against the caliper.

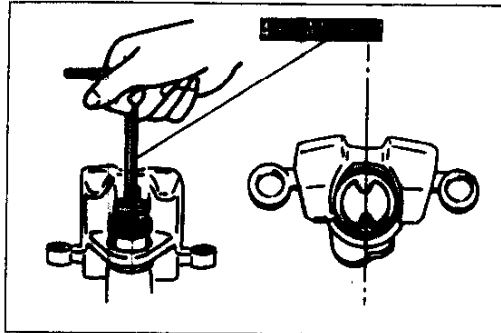

37U0PX-053

Piston

1. Clean the piston with clean brake fluid.
2. Install the new dust boot in the piston groove.
3. Turn the piston into the caliper body by rotating the **SST** clockwise.

Note

- Turn the piston in fully, and align the piston grooves as shown in the illustration.
4. Fit the dust boot into the caliper body.

PARKING BRAKE SYSTEM TROUBLESHOOTING GUIDE

Problem	Possible cause	Action	Page
Brakes do not release	Improper return of parking cable or improper adjustment	Repair or adjust	P-33
Parking brake does not hold well	Excessive parking brake lever stroke	Adjust	P-32
	Parking cable stuck or damaged	Repair or replace	P-33
	Brake fluid or oil on pads	Clean or replace	P-28
	Hardening of pad surfaces or poor contact	Grind or replace	P-28

37U0PX-055

PARKING BRAKE (LEVER TYPE)

Inspection

Parking brake lever stroke

1. Depress the brake pedal several times.
2. Pull and release the parking brake lever several times.
3. Verify that the stroke is within specification when the parking brake lever is pulled with a force of **200 N {20 kgf, 44 lbf}**.

Stroke: 7-10 notches

4. If not within specification, adjust the parking brake lever stroke. (Refer to below.)

Adjustment

Parking brake lever stroke

1. Depress the brake pedal several times.
2. Pull and release the parking brake lever several times.
3. Remove the console panel. (Refer to Section S.)
4. Adjust the parking brake lever stroke by turning the adjusting nut.

Stroke: 7-10 notches

Caution

- After adjustment, verify that the parking brake warning lamp illuminates when the parking brake lever is pulled one notch.
- Verify that the brakes do not drag when the wheels are turned by hand.

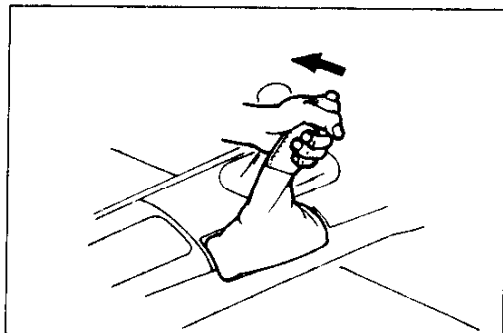

37U0PX-056

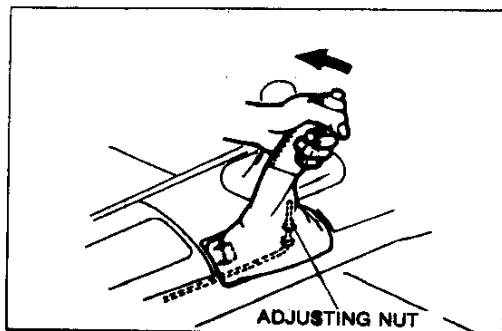

37U0PX-057

PARKING CABLE (LEVER TYPE)

Removal / Inspection / Installation

1. Remove in the order shown in the figure.
2. Inspect all parts and repair or replace as necessary.
3. Install in the reverse order of removal.
4. After installation, check the parking brake lever stroke. (Refer to page P-32.)

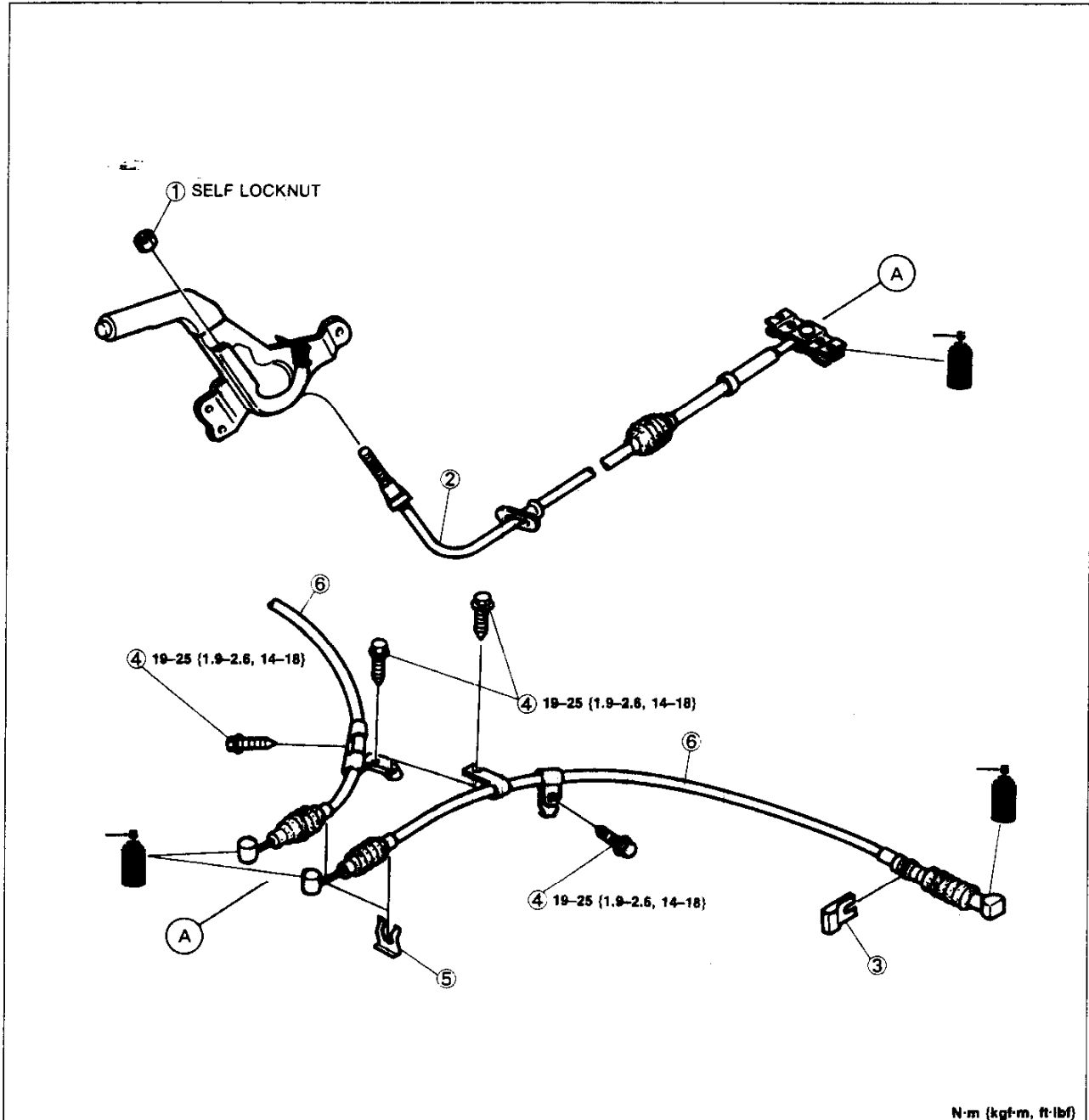

N·m (kgf·m, ft·lbf)

37U0PX-058

1. Adjusting nut
2. Front parking cable
Inspect for damage and wear

3. Clip
4. Bolt

5. Clip
6. Rear parking cable
Inspect for damage and wear

P

PARKING BRAKE SYSTEM

PARKING BRAKE LEVER

Removal / Inspection / Installation

1. Remove the console panel. (Refer to Section S.)
2. Remove the rear console. (Refer to Section S.)
3. Remove in the order shown in the figure.
4. Inspect all parts and repair or replace as necessary.
5. Install in the reverse order of removal, referring to **Installation Note**.
6. After installation, check the parking brake lever stroke. (Refer to page P-32.)

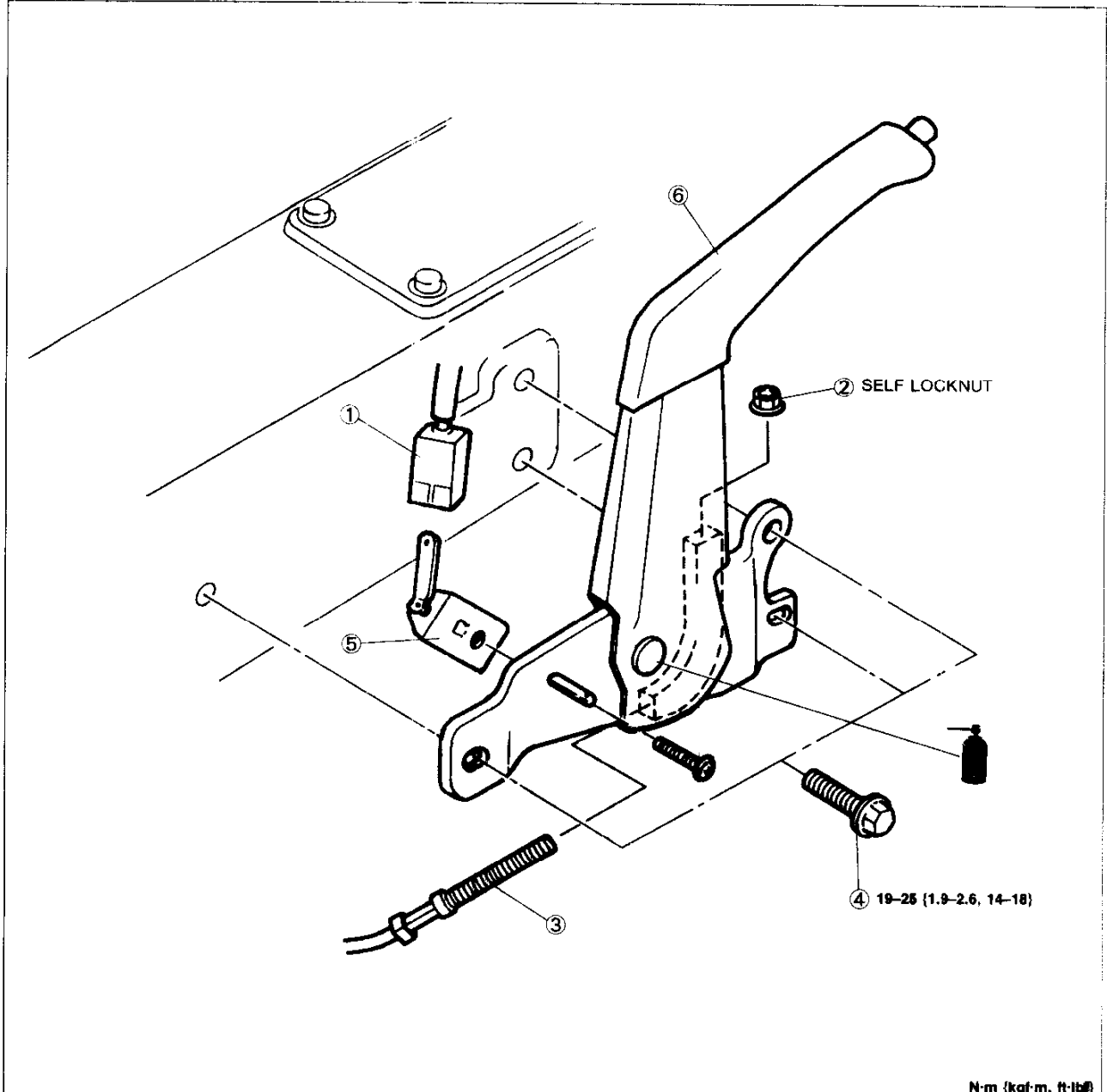

N·m (kgf·m, ft·lb)

37U0PX-059

1. Parking brake switch connector
2. Adjusting nut
3. Front parking cable

4. Bolt
Inspection page P-35
Installation Note
..... page P-35

6. Parking brake lever
Inspect for damage and bending

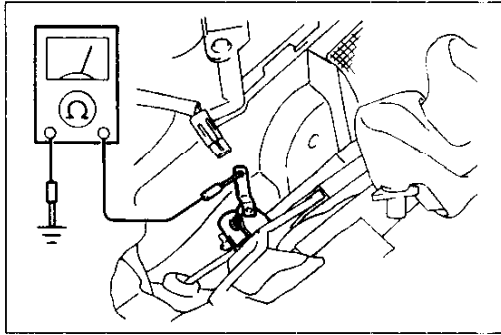

37U0PX-060

Inspection

Parking brake switch

1. Remove the console panel. (Refer to Section S.)
2. Disconnect the connector from the parking brake switch.
3. Pull the parking brake lever and check continuity between the terminal of the switch and a ground.

Parking brack lever	Continuity
Released	No
Pulled	Yes

4. If not as specified, replace the parking brake switch.

Installation note

Parking brake switch

1. Install the parking brake switch so that it contacts the parking brake lever when the lever is fully released.
2. Turn the ignition switch ON, and check that the parking brake warning lamp illuminates with the lever is pulled one notch.

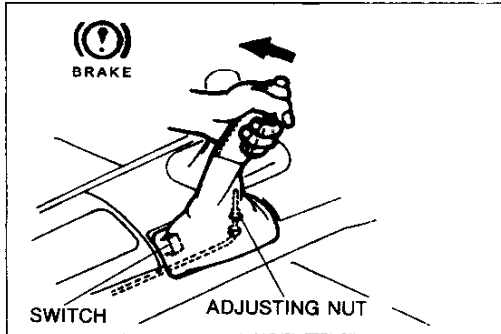

37U0PX-061



P

ANTI-LOCK BRAKE SYSTEM (ABS)

ANTI-LOCK BRAKE SYSTEM (ABS)

PREPARATION

SST

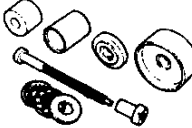
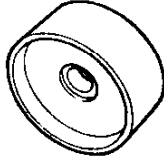
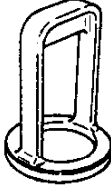
<p>49 H066 003 Harness, adapter</p> 	<p>For connecting ABS tester</p>	<p>49 0259 770B Wrench, flare nut</p> 	<p>For removal / installation of brake pipe</p>
<p>49 H028 2A0 Set, rubber bushing replacer</p> 	<p>For installation of sensor rotor (front)</p>	<p>49 H028 204 Attachment (Part of 49 H028 2A0)</p> 	<p>For installation of sensor rotor (front)</p>
<p>49 F026 104 Installer, sensor rotor</p> 	<p>For installation of sensor rotor (rear)</p>	<p>37U0PX-062</p>	

TROUBLESHOOTING GUIDE

Outline

The ABS tester is used to locate the cause of a problem within the anti-lock brake system by retaining and reducing the hydraulic fluid pressure in the hydraulic unit. Because there is no way to check the ABS control unit itself, replace the control unit assembly only after first confirming that the other electrical parts are not faulty.

ABS tester

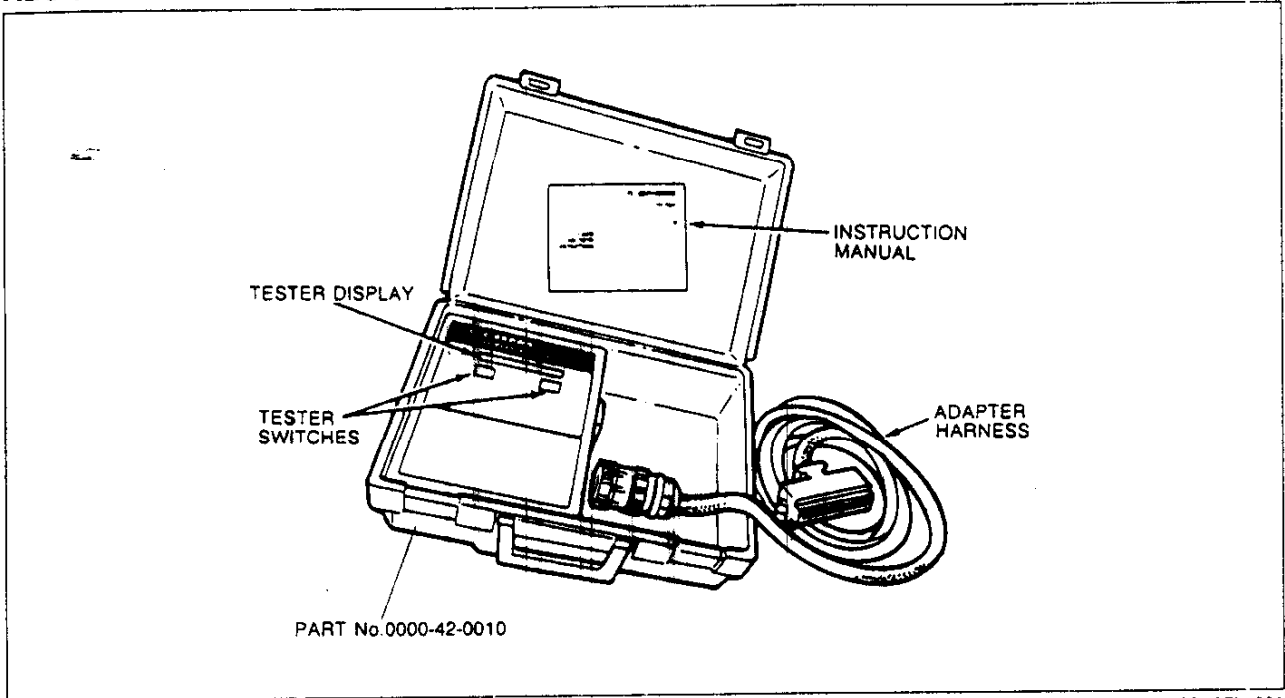

29U0PX-091

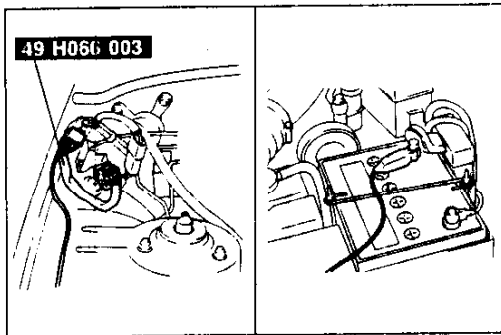

37U0PX-063

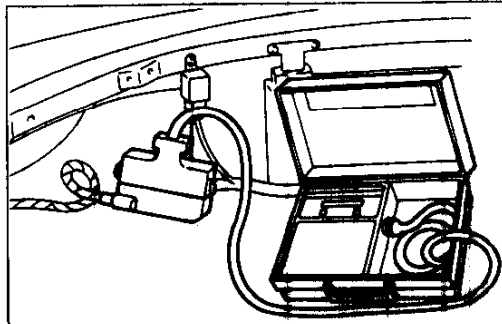

37U0PX-522

Connecting the ABS tester

1. Turn the ignition switch OFF.
2. Connect the **SST** between the hydraulic unit wiring harness connectors and to the positive battery terminal.
3. Remove the trunk side trim.
4. Remove the ABS control unit.
5. Disconnect the control unit connector and connect the ABS tester to the control unit connector at the harness side.

Explanation of instruction procedure

EXPLANATION OF INSTRUCTION PROCEDURE

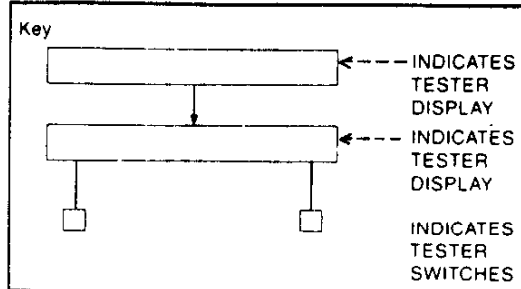

Example:
5B "Brake light
switch test"

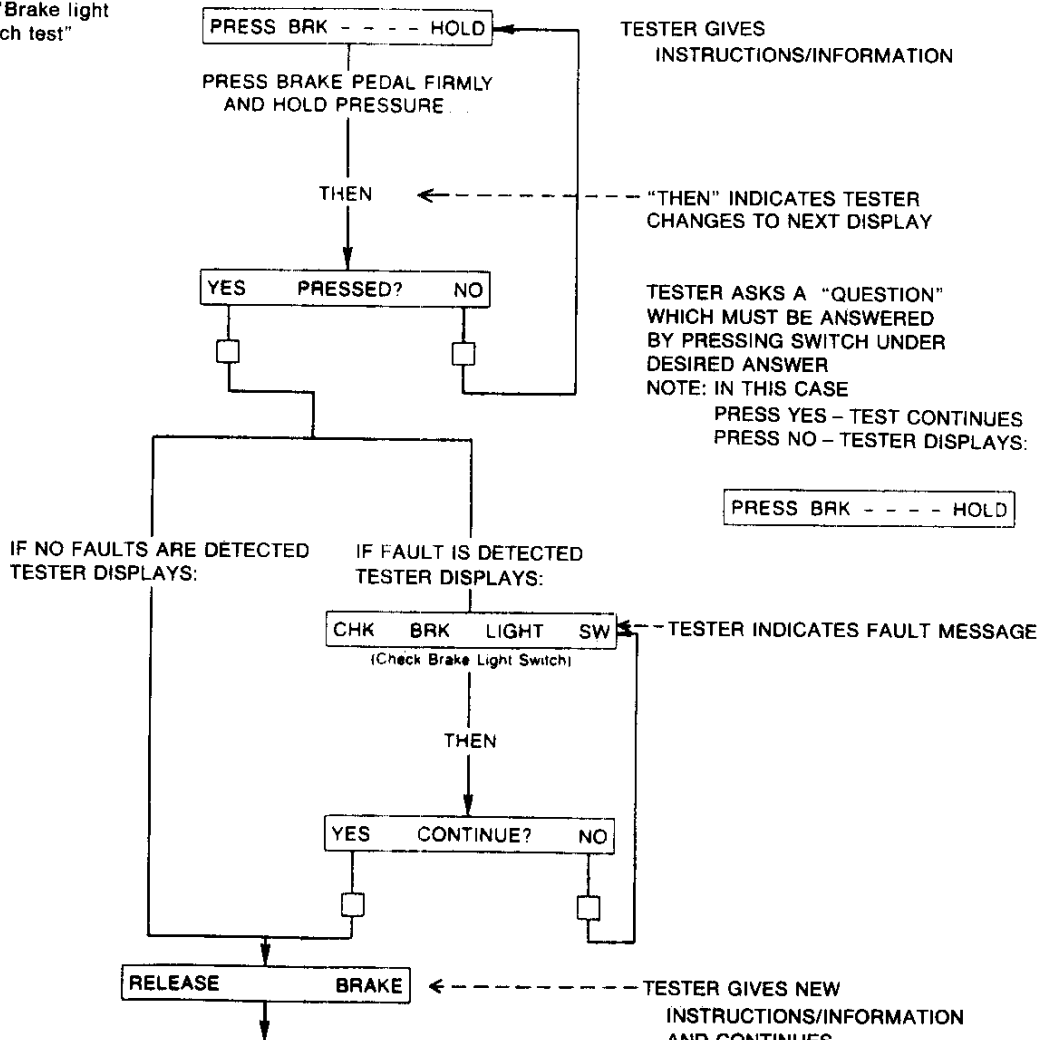

Troubleshooting procedure

ITEM	
<p>1. CONNECTION / POWER ON</p>	<p>1. Locate ABS control unit 2. Disconnect control unit harness connector from control unit 3. Connect ABS tester harness to control unit harness connector. 4. Turn ignition key to ON position.</p>
<p>2. ALTERNATOR TEST ● Start engine</p>	<p>Tester rapidly displays several messages during initial segment check.</p> <pre> graph TD Start(()) -- THEN --> Box1[MAZDA ABS 2 TEST] Box1 --> Box2[YES ENG RUN? NO] Box2 --> Box3[MAZDA ALT TEST] Box3 --> Box4[CHK ALTERNATOR] Box4 --> Box5[YES CONTINUE? NO] Box5 --> NoFault[No fault detected] Box5 --> Box4 NoFault --> Box6[TURN OFF ENGINE] </pre>
<p>3. ABS SYSTEM TEST ● Turn ignition key ON (Do not run engine)</p>	<p>Tester rapidly displays several messages during initial segment check.</p> <pre> graph TD Start(()) -- THEN --> Box1[YES ENG RUN? NO] Box1 --> Box2[MAZDA ABS 2 TEST] Box2 --> Cont["(Cont.)"] </pre>

ANTI-LOCK BRAKE SYSTEM (ABS)

4. SYSTEM VOLTAGE CHECKS

- If tester displays a fault message, check and repair or replace parts as necessary.

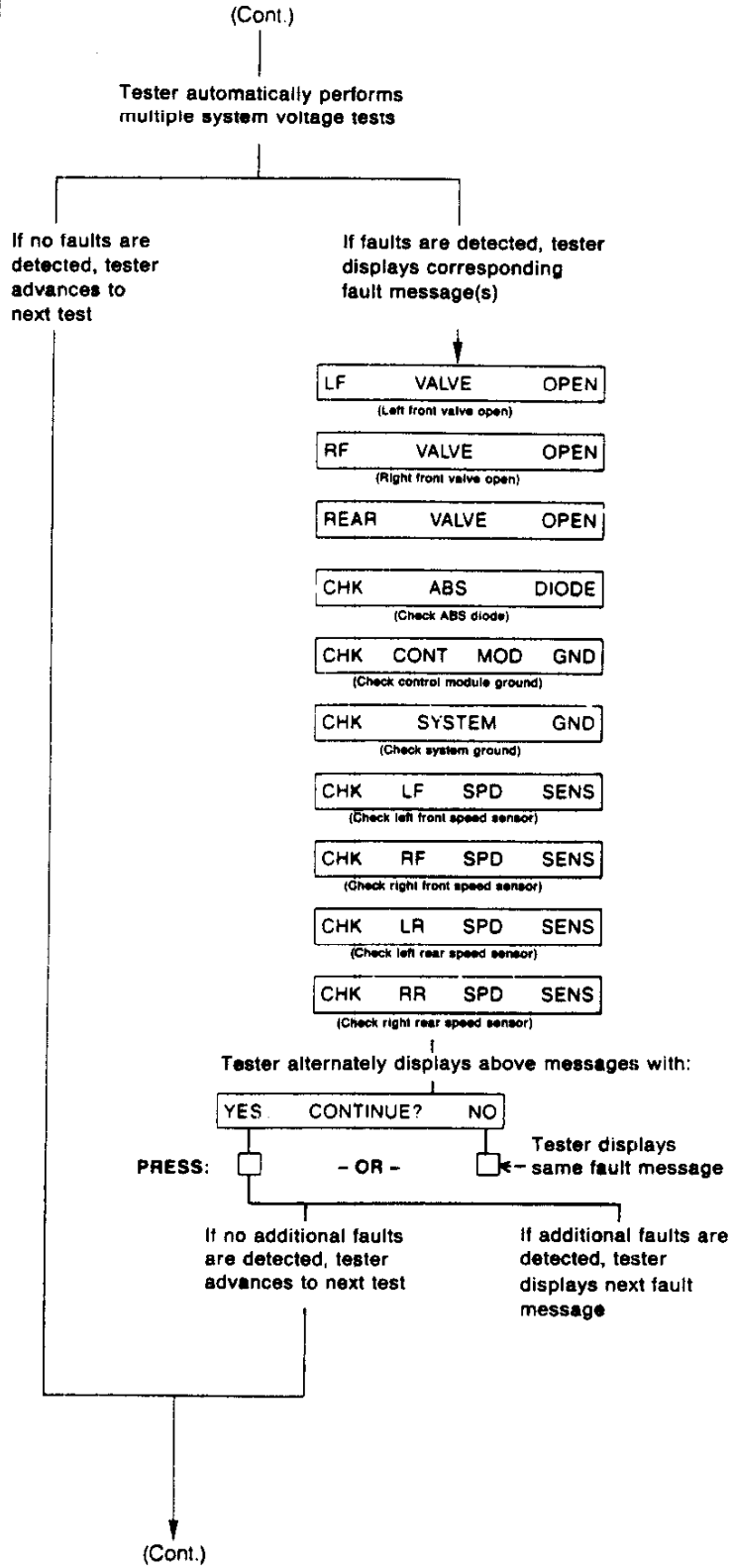

5. STATIC TESTS
5A ABS WARNING LAMP TEST

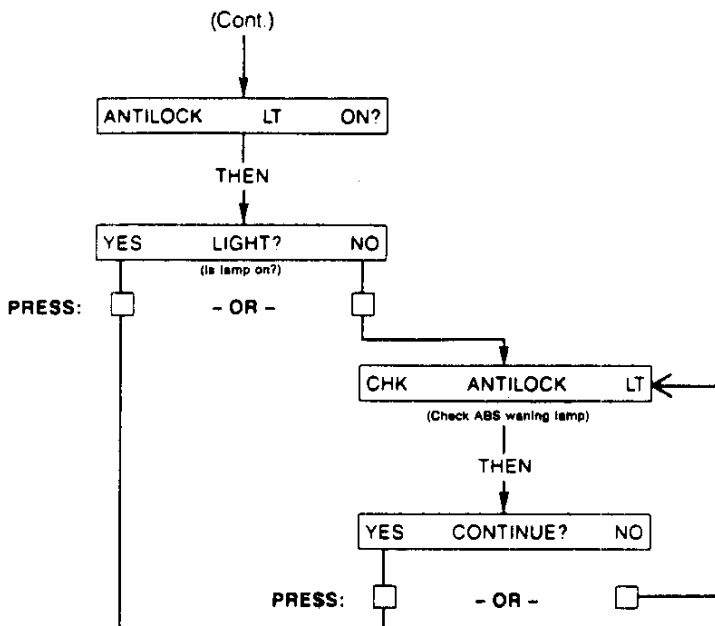

5B. BRAKE LIGHT SWITCH TEST

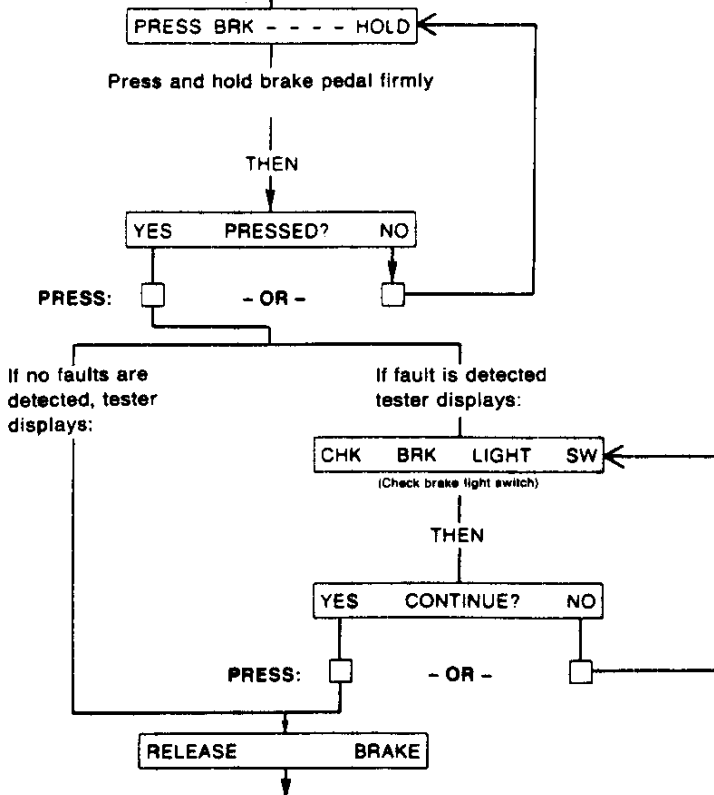

5C PUMP TEST

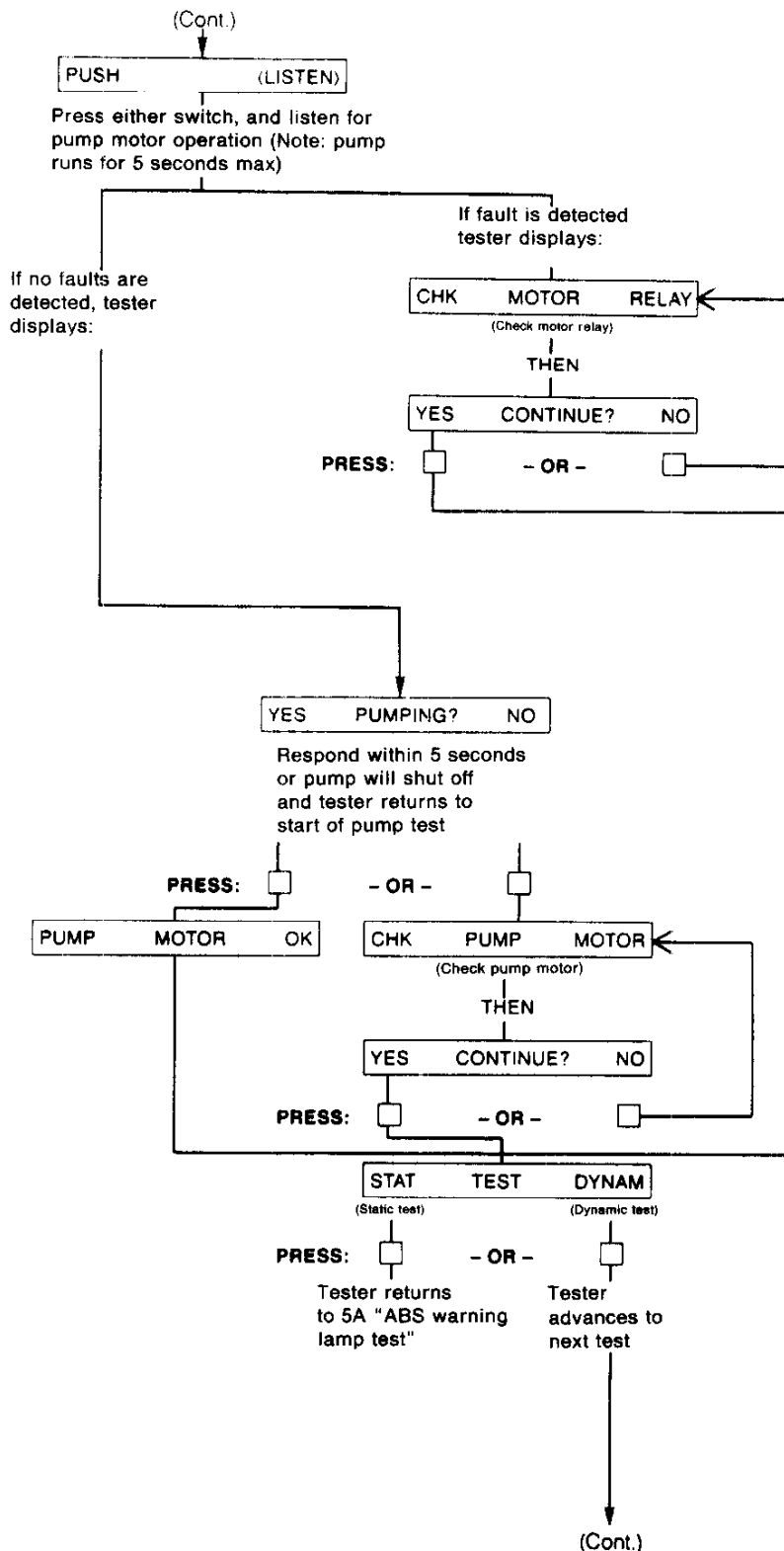

6. DYNAMIC TESTS
6A WHEEL SELECTION OR EXIT

Each messages will displayed 3-1/2 seconds

Select one wheel to begin dynamic test sequence

OR

Press either switch under "PUSH TO EXIT" to return to "STAT TEST DYNAM" selection

IMPORTANT:

After completing testing of selected wheel return to 6A "WHEEL SELECTION," to select another wheel
Complete test procedures for all four wheels

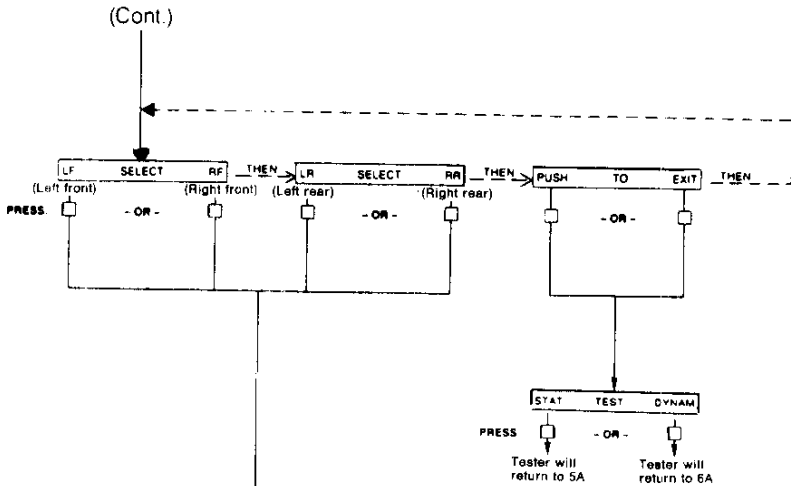

NOTE: Raise vehicle and support it on safety stands.
An assistant is required to spin wheels.

6B WHEEL SENSOR TEST

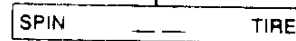

(Cont.)

ANTI-LOCK BRAKE SYSTEM (ABS)

6B WHEEL SENSOR TEST

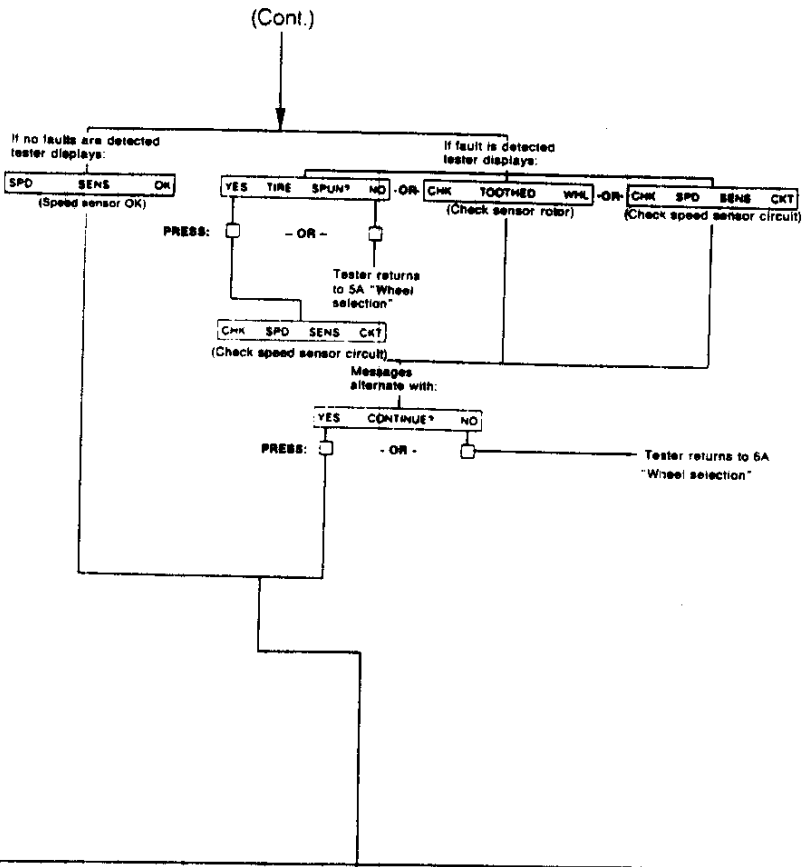

6C SOLENOID TEST

NOTE: Each solenoid test can be conducted for 15 seconds max
If time limit exceeded, tester displays:

TIMEOUT EXPIRED

THEN

TRY TEST AGAIN

PUSH TEST 1

Press either switch to start test
tester displays:

PRESS BRK ... HOLD

Apply firm pressure to brake pedal and hold firmly through out solenoid test 1 and 2

(Cont.)

6C SOLENOID TEST

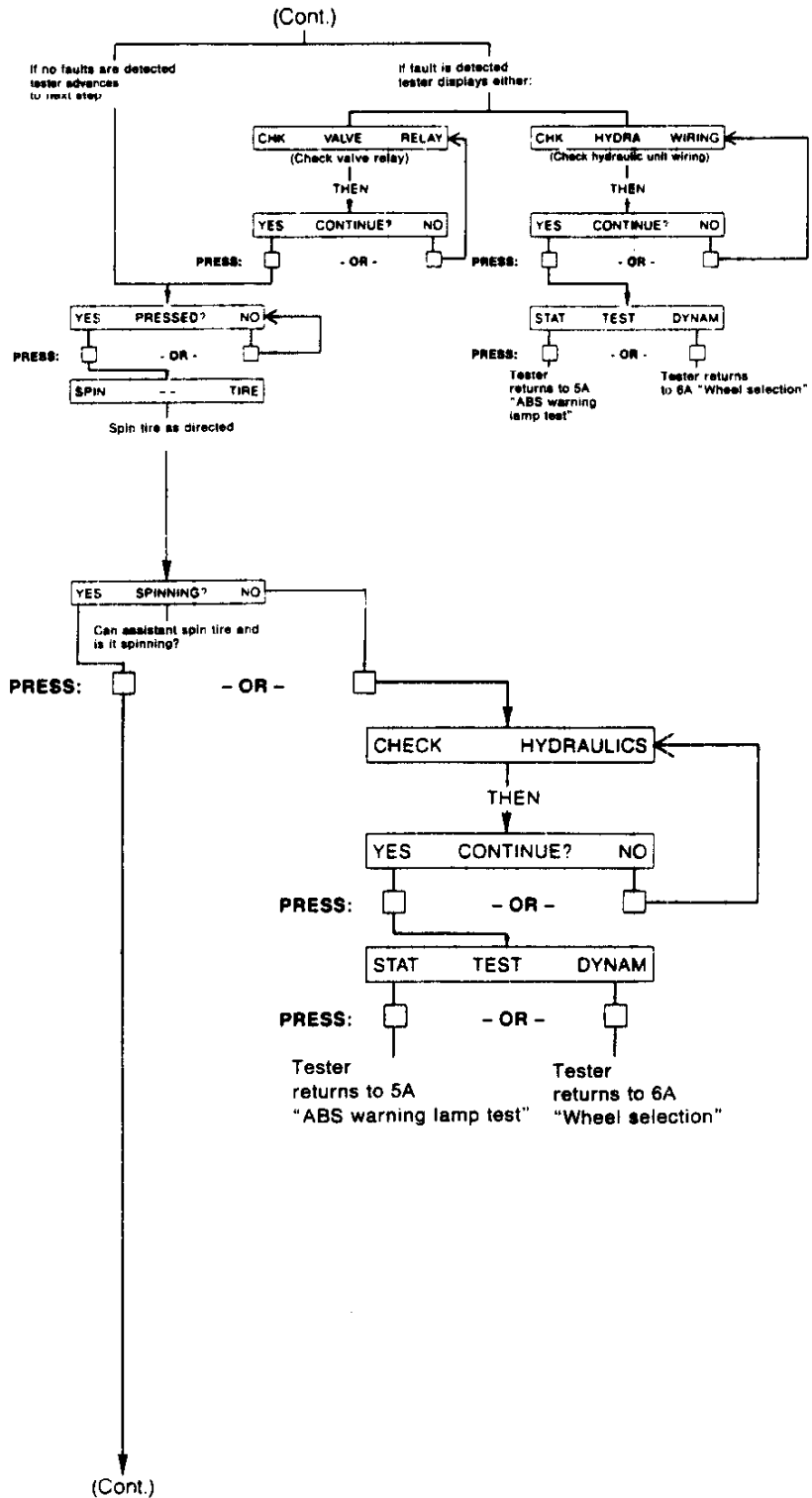

ANTI-LOCK BRAKE SYSTEM (ABS)

6C SOLENOID TEST

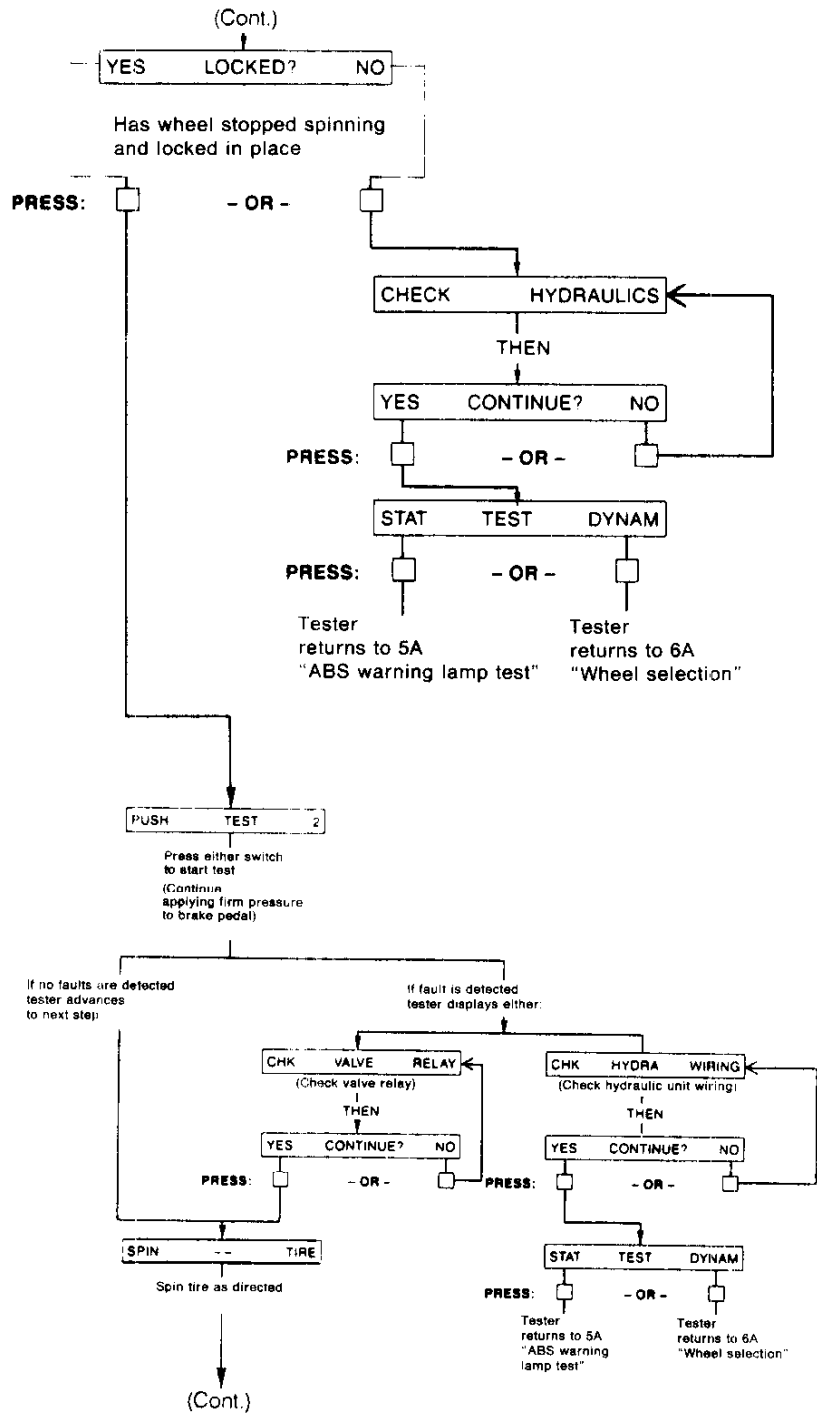

6C SOLENOID TEST

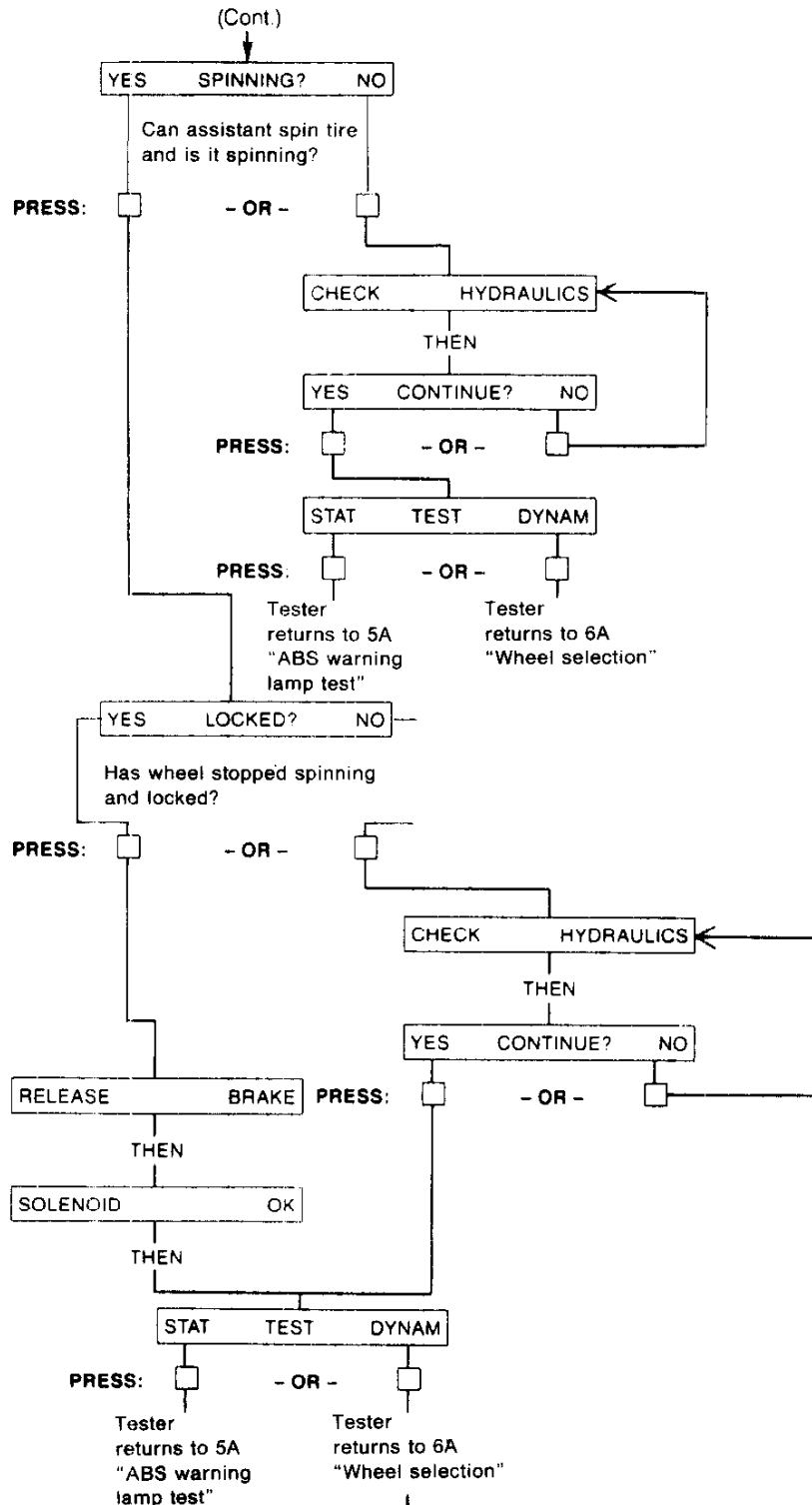

IMPORTANT—Continue returning to 6A until all four wheels have been tested.

P

ANTI-LOCK BRAKE SYSTEM (ABS)

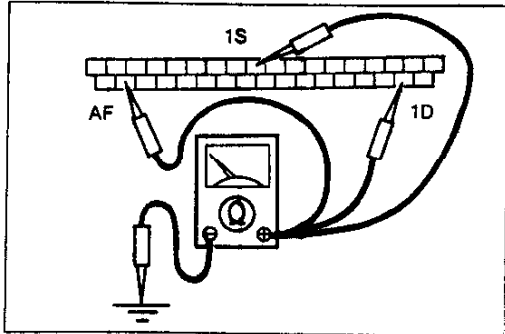

37U0PX-074

Inspection of ABS system Check system ground

Check for an open circuit in (B) wire from terminals 1D, 1S, and AF of the ABS control unit O-01 connector and ground.

Caution

- When checking the control unit terminal, do not use ordinary tester pins. Use only very thin pins to prevent damage to the terminals.

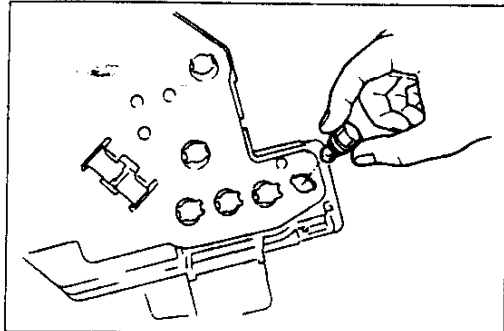

37U0PX-075

Check anti-lock warning lamp

1. Remove the switch assembly. (Refer to 1993 RX-7 body electrical troubleshooting manual section Z4.)
2. Remove and check the ABS warning lamp bulb.
3. If a problem is found, replace the bulb.
4. If OK repair or replace the wiring harness. (Battery-AES control unit-ABS warning lamp)

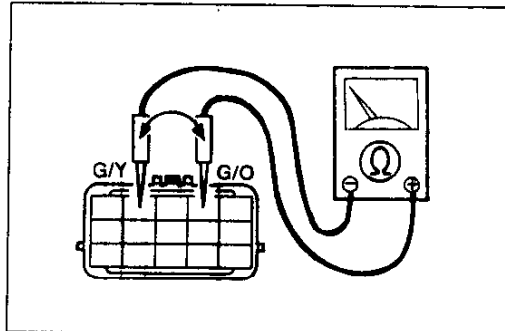

37U0PX-076

Check ABS diode

1. Check the wiring harness between the warning lamp and the control unit and hydraulic unit. Repair if necessary.
2. Disconnect the hydraulic unit O-02 connector.
3. Using an ohmmeter, check for continuity between the terminals of the connector (hydraulic unit side).

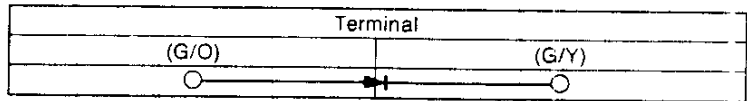

○-○: Continuity

4. If continuity is not specified, replace the hydraulic unit.

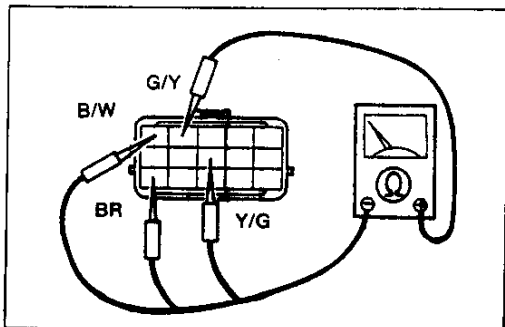

37U0PX-077

Check front and rear valves

1. Disconnect the negative battery cable.
2. Disconnect the hydraulic unit O-02 connector.
3. Check for continuity between terminals of the connector (hydraulic unit side).

Wire	Continuity
(G/Y) (Y/G)	Yes
(G/Y) (BR)	Yes
(G/Y) (B/W)	Yes

4. If not as specified, replace the hydraulic unit.

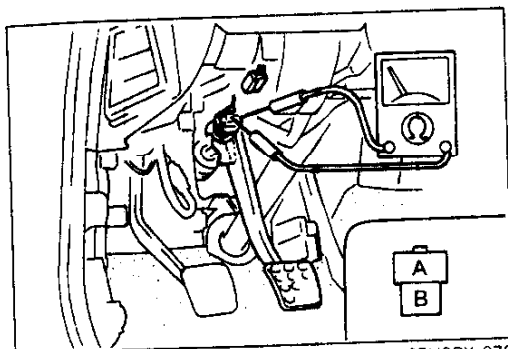

37U0PX-078

Check stoplight switch

1. Disconnect the stoplight switch connector.
2. Connect an ohmmeter between terminals of the switch.
3. Verify that there is continuity between the terminals when the brake pedal is depressed.
4. If there is no continuity, replace or adjust the stoplight switch.

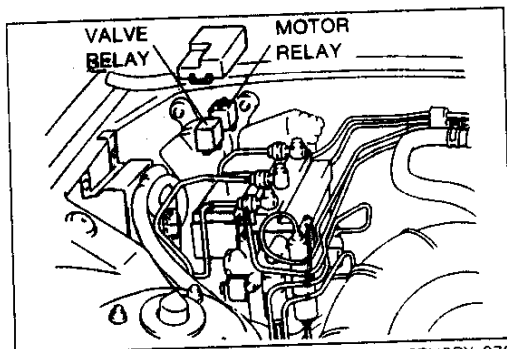

37U0PX-079

Check motor relay

1. Disconnect the negative battery cable.
2. Remove the motor relay.

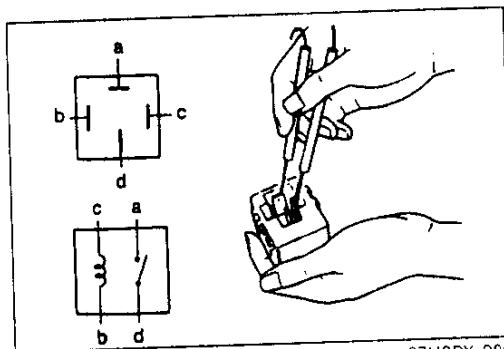

37U0PX-080

3. Using an ohmmeter, check continuity between terminals of the relay.

Connect to		a	b	c	d
12V	Ground				
-	-		○—○		
c	b	○—○			○—○

○—○: Continuity

4. If continuity is not as specified, replace the motor relay.

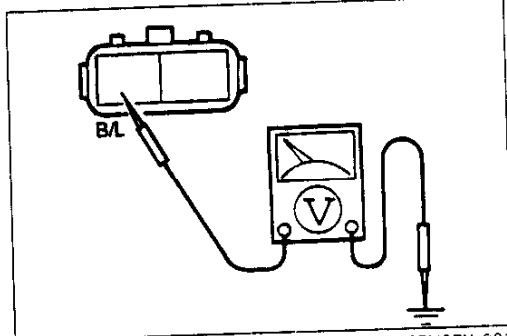

37U0PX-081

Check pump motor

1. Disconnect the hydraulic unit O-03 connector.
2. Measure the voltage between wire (B/L) and a ground.

Wire	Voltage
(B/L)	Battery voltage

3. If not as specified, check the fuse (MAIN and ABS 60A) and repair or replace the wiring harness (battery-hydraulic unit).

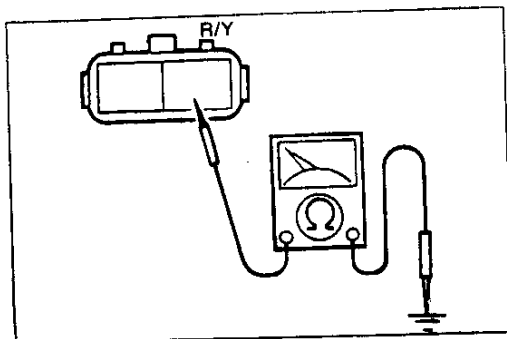

37U0PX-082

4. If as specified, check for continuity between wire (C) of O-03 connector and a ground (hydraulic unit side).

Wire	Continuity
(R/Y)	Yes

5. If there is no continuity, replace the hydraulic unit.

P

ANTI-LOCK BRAKE SYSTEM (ABS)

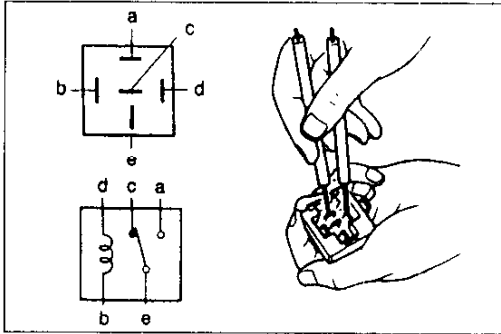

37J0PX-183

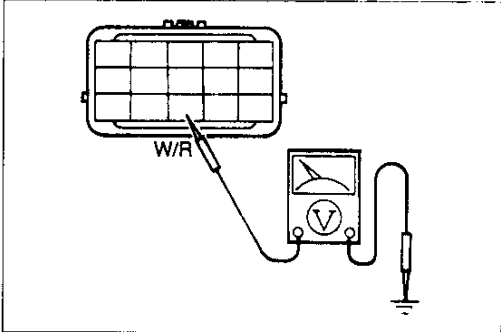

37J0PX-184

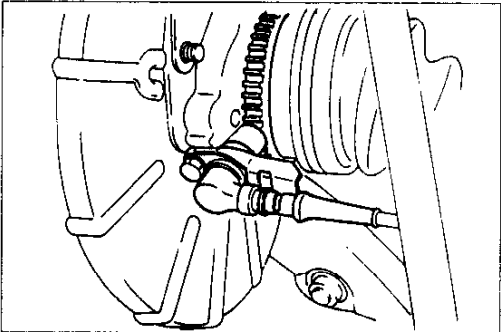

37U0PX-185

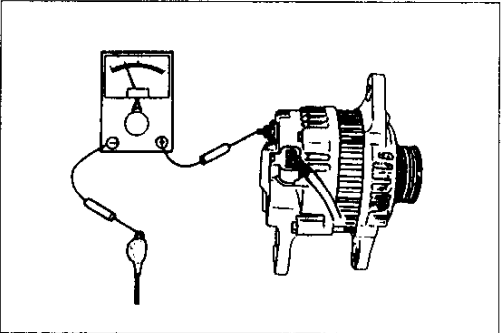

29U0PX-15

Check valve relay

1. Disconnect the negative battery cable.
2. Remove the valve relay.
3. Using an ohmmeter, check continuity between terminals of the relay.

Connect to		a	b	c	d	e
12V	Ground					
--	--			○	○	○
			○		○	
b	d	○				○

○-○: Continuity

4. If continuity is not as specified, replace the valve relay.
5. If as specified, connect the negative battery cable.
6. Disconnect the hydraulic unit O-02 connector.
7. Measure voltage between wire (W/R) of O-02 connector and ground.

Wire (W/R)	Voltage
	Battery voltage

8. If not as specified, check the fuse (MAIN and ABS 15A) and repair or replace the wiring harness (battery-hydraulic unit).

Check rotor

1. Check the rotor for looseness and missing or damaged teeth.
2. Replace if necessary.

Check alternator

Refer to Section G.

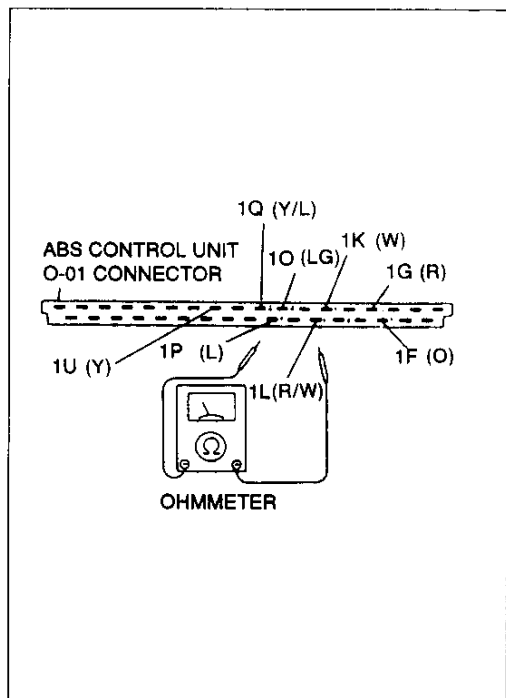

37U0PX-086

Check wheel-speed sensor

1. Disconnect the O-01 connector.
2. Using an ohmmeter, check for continuity between the ABS control unit O-01 connector terminals.

	Terminal							
Sensor	1K	1G	1O	1Q	1U	1F	1L	1P
Left front	○—○							
Right front					○—○			
Left rear			○—○					
Right rear							○—○	

○—○: Continuity

2. If the continuity is not as specified, repair the wiring harness (wheel-speed sensor-ABS control unit).
3. If continuity is as specified, check voltage between the following terminals while rotating the wheel one rotation per second by hand.

Sensor	Terminal	Voltage
Left front	1K and 1G	50-60 mV*
Right front	1U and 1F	50-60 mV*
Left rear	1O and 1Q	50-60 mV*
Right rear	1L and 1P	50-60 mV*

*Alternating current voltage

4. If voltage is not as specified, replace the wheel-speed sensor.
5. If voltage is as specified, replace the ABS control unit.

Caution

- When checking the control unit terminals, do not use ordinary tester pins. Use only very thin pins to prevent damage to the terminals.

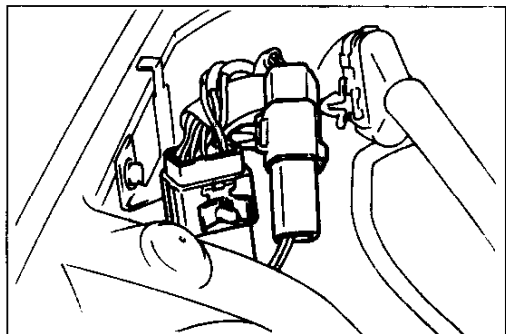

37U0PX-087

Check hydraulics

Verify that all brake fluid line connections are tight and that no fluid is leaking.

Check hydraulic unit wiring

1. Verify that the hydraulic unit connectors are properly secured.
2. Verify that the valve relay and motor relay are properly secured.

SERVICE POINTS
Circuit Diagram

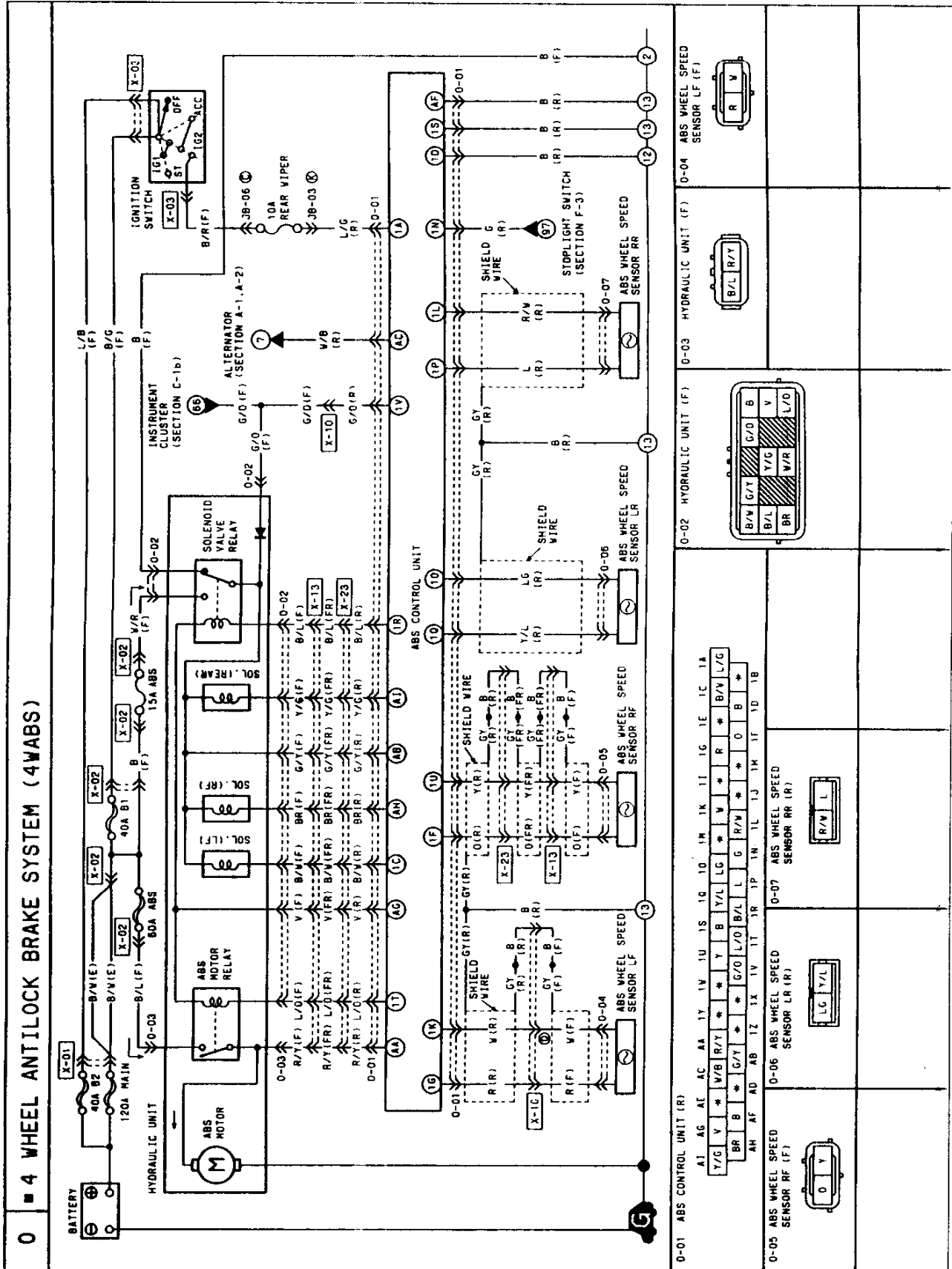

**Electrical diagnosis support
Hydraulic unit (HU)**

Circuit	Condition		
	Open circuit	Short circuit	Poor ground
Valve relay, motor relay and solenoid valve-ABS CU	System shut down ↓ Normal braking	System shut down ↓ Normal braking	NA
HU-Fuse-Battery	System shut down ↓ Normal braking	System shut down ↓ Normal braking Fuse (ABS) burns out	NA
Motor-Ground	System shut down ↓ Normal braking	No symptom	System shut down ↓ Normal braking
O-02 connector (B) -Ground	ABS warning lamp does not illuminate when ABS CU disconnected	No symptom	ABS warning lamp does not illuminate when ABS CU disconnected
HU-ABS warning lamp	ABS warning lamp does not illuminate when ABS CU disconnected	ABS warning lamp illuminates continuously	NA

37U0PX-088

Wheel-speed sensor

Circuit	Condition		
	Open circuit	Short circuit	Poor ground
Wheel speed sensor-ABS CU	Partial control	Partial control	NA

37U0PX-089

Partial control: If failure occurs during ABS operation, system is controlled by remaining sensors until ABS cycle is completed, then system is shut down.

NA: Not applicable

ANTI-LOCK BRAKE SYSTEM (ABS)

ABS control unit (ABS CU)

Circuit	Condition		
	Open circuit	Short circuit	Poor ground
ABS CU-Ignition switch-Battery	System shut down ↓ Normal braking	System shut down ↓ Normal braking	NA
ABS CU-Stoplight switch-Battery	ABS Controllability slightly down on low coefficient road, but no other effects	Fuse (AIR CON 15A) burns out ABS Controllability slightly down on low coefficient road, but no other effects	NA
ABS CU-Alternator	ABS warning lamp remains illuminated after engine started ABS control normal	Fuse (STOP 20A) burns out ABS warning lamp remains illuminated after engine started ABS control normal	NA
ABS CU-Ground	If all ground harnesses are open, system shut down	No symptom	If all ground harnesses are open, system shut down
ABS CU-ABS warning lamp	ABS warning lamp does not illuminate when ABS CU disconnected ABS warning lamp does not illuminate when ignition switch is ON and system has been shut down	ABS warning lamp illuminates continuously	NA

NA: Not applicable

HYDRAULIC UNIT

Removal / Installation

1. Disconnect the negative battery cable
2. Remove in the order shown in the figure, referring to **Removal Note**.

Caution

- **The only serviceable parts of the hydraulic unit are the valve relay and the motor relay, if there is a failure of any other part, replace the hydraulic unit assembly.**

3. Install in the reverse order of removal, referring to **Installation Note**.
4. After installation, perform the following.
 - (1) Add fluid and bleed the air. (Refer to page P-7.)
 - (2) Check for fluid leakage. (Refer to page P-8.)

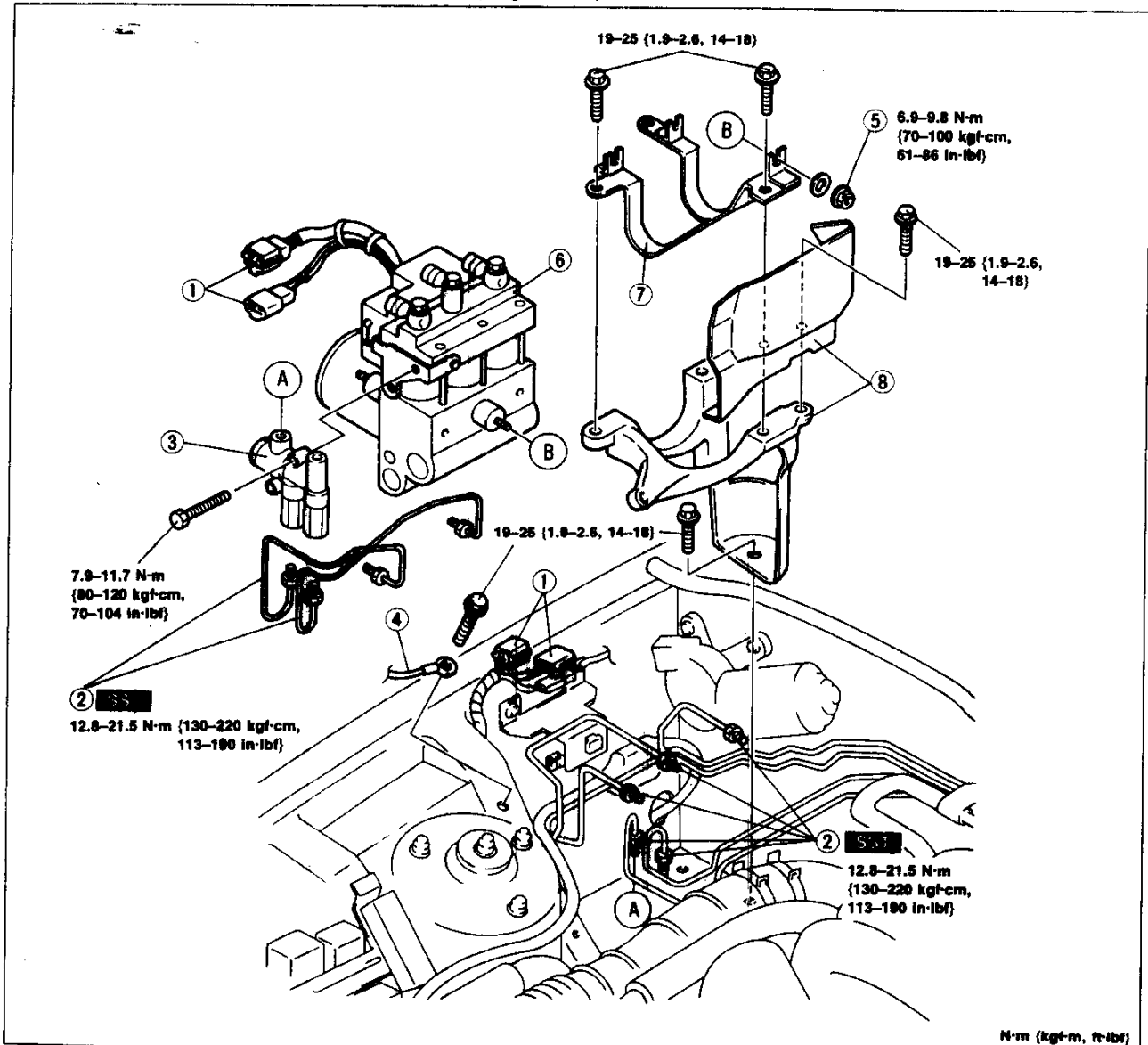

N-m (kgf-cm, ft-lbf)

37U0PX-091

- | | | |
|-------------------|-------------------------------|--------------------------|
| 1. Connector | 3. Proportioning bypass valve | 7. ABS bracket |
| 2. Brake pipe | 4. Ground wire | 8. Insulator and bracket |
| Removal Note | 5. Nut | |
| page P-56 | 6. Hydraulic unit | |
| Installation Note | Disassembly / Inspection / | |
| page P-56 | Assembly page P-56 | |

ANTI-LOCK BRAKE SYSTEM (ABS)

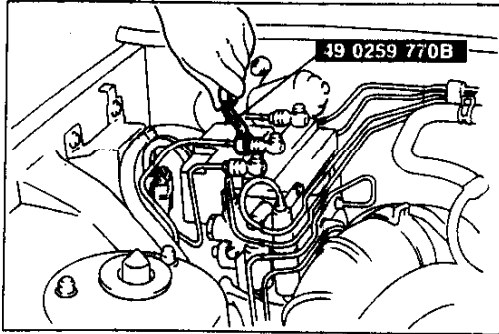

37UOPX-106

Removal / Installation note Brake pipe

Caution

- Be careful not to spill the brake fluid onto a painted surface. If spilled, wipe it up immediately.

Loosen / tighten the brake pipe by using the **SST**.

Disassembly / Inspection / Assembly

1. Disassemble in the order shown in the figure.
2. Inspect all parts and repair or replace as necessary.
3. Assemble in the reverse order of disassembly.

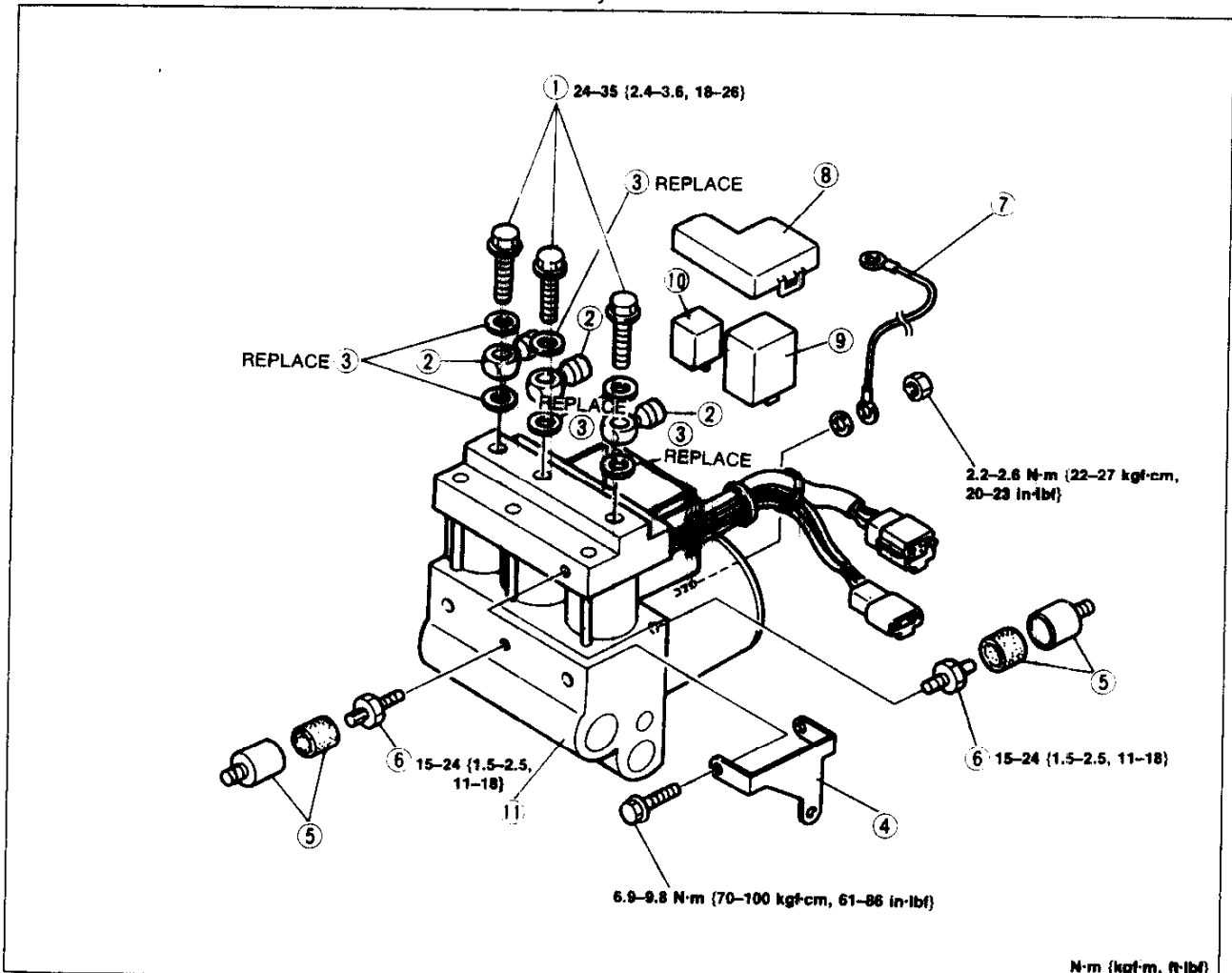

37UOPX-092

- | | | |
|--------------------------------------|----------------------------|----------------------------|
| 1. Connector bolt | 5. Casing and mount rubber | 9. Motor relay |
| 2. Pipe joint | 6. Hex stud | Inspection page P-62 |
| 3. Gasket | 7. Ground wire | 10. Valve relay |
| 4. Proportioning bypass valve holder | 8. Cover | Inspection page P-62 |
| | | 11. Hydraulic unit |

ABS CONTROL UNIT

Removal / Installation

1. Disconnect the negative battery cable.
2. Remove the luggage compartment side trim. (Refer to Section S.)
3. Remove in the order shown in the figure.
4. Install in the reverse order of removal.

Caution

- Connect the connector securely. If a poor contact occurs, the ABS system may malfunction.

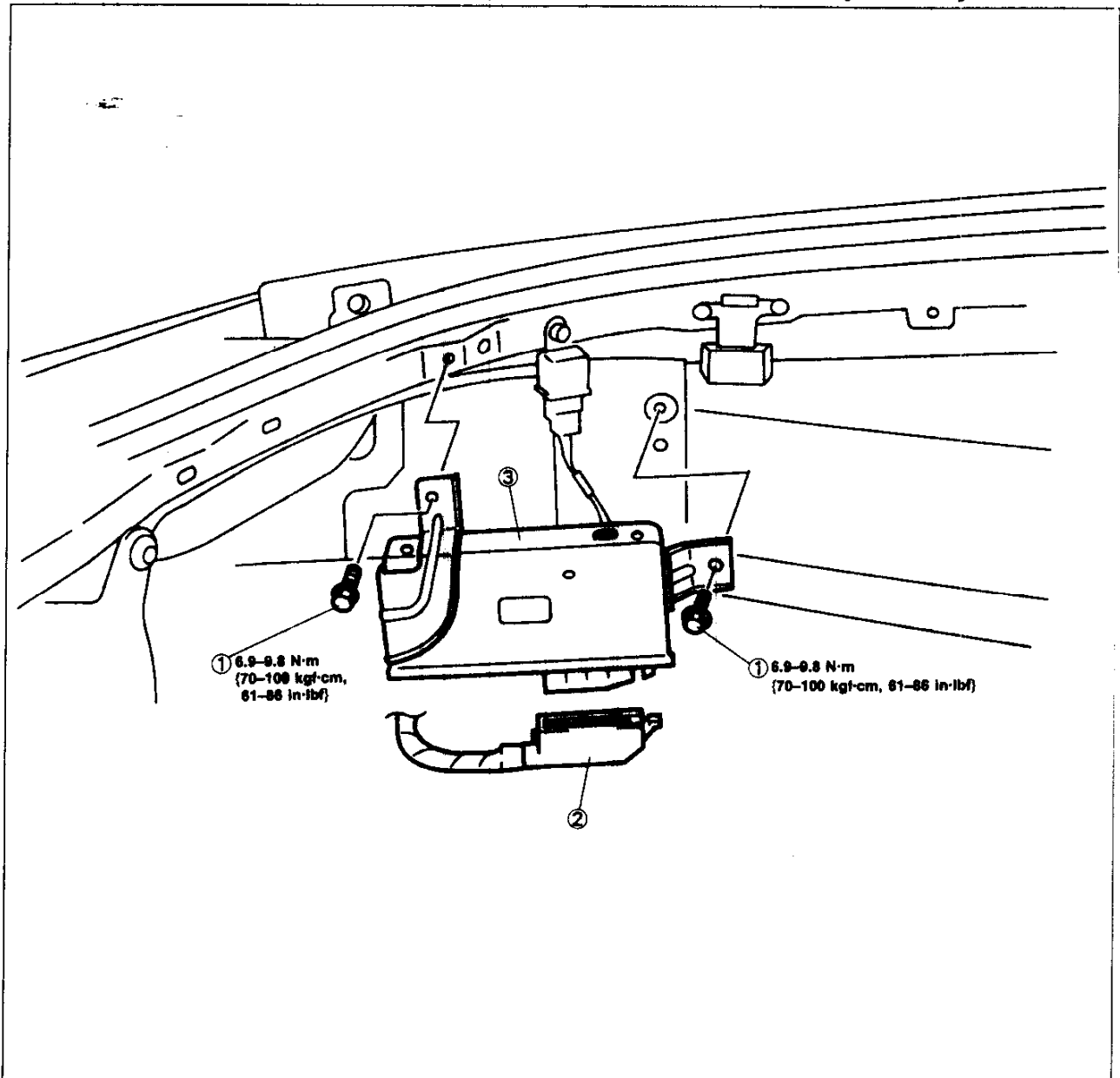

37U0PX-093

1. Bolt

2. Connector

3. ABS control unit

P

ANTI-LOCK BRAKE SYSTEM (ABS)

WHEEL-SPEED SENSOR (FRONT)

Removal / Installation

1. Remove in the order shown in the figure.
2. Install in the reverse order of removal.

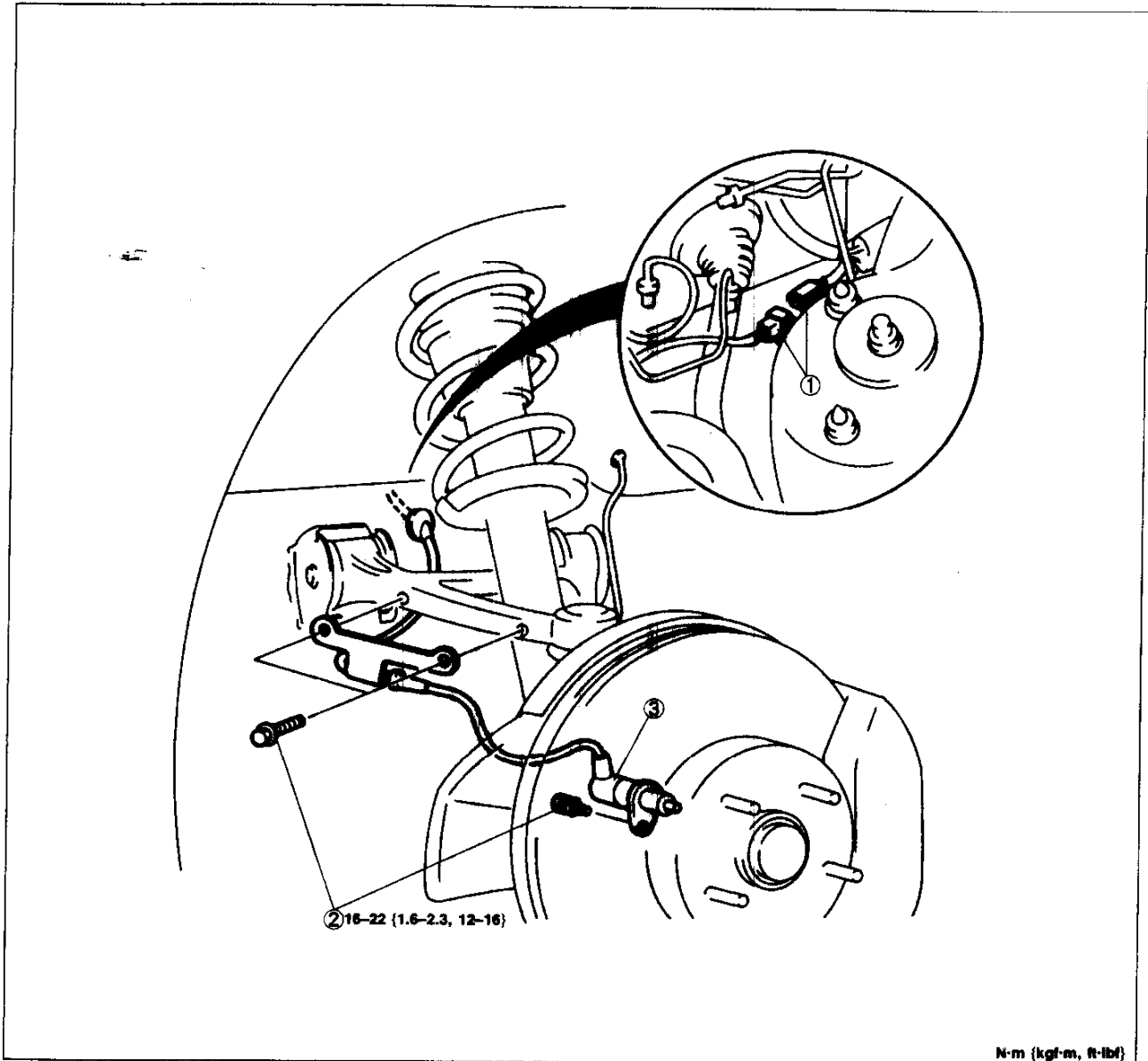

N·m (kgf·m, ft·lbf)

370PX-094

1. Connector
2. Bolt

3. Wheel-speed sensor (front)
Inspection below

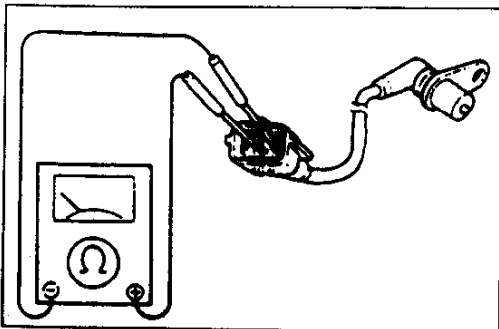

37UOPX-095

Inspection

Wheel speed sensor (front)

1. Measure resistance between terminals of the wheel-speed sensor.

Resistance: 0.8–1.2 k Ω

2. If resistance is not as specified, replace the wheel-speed sensor.

SENSOR ROTOR (FRONT)

Removal / Installation

1. Remove the wheel hub assembly from the vehicle. (Refer to Section M.)
2. Remove in the order shown in the figure, referring to **Removal Note**.
3. Install in the reverse order of removal, referring to **Installation Note**.
4. Install the wheel hub assembly to the vehicle. (Refer to Section M.)

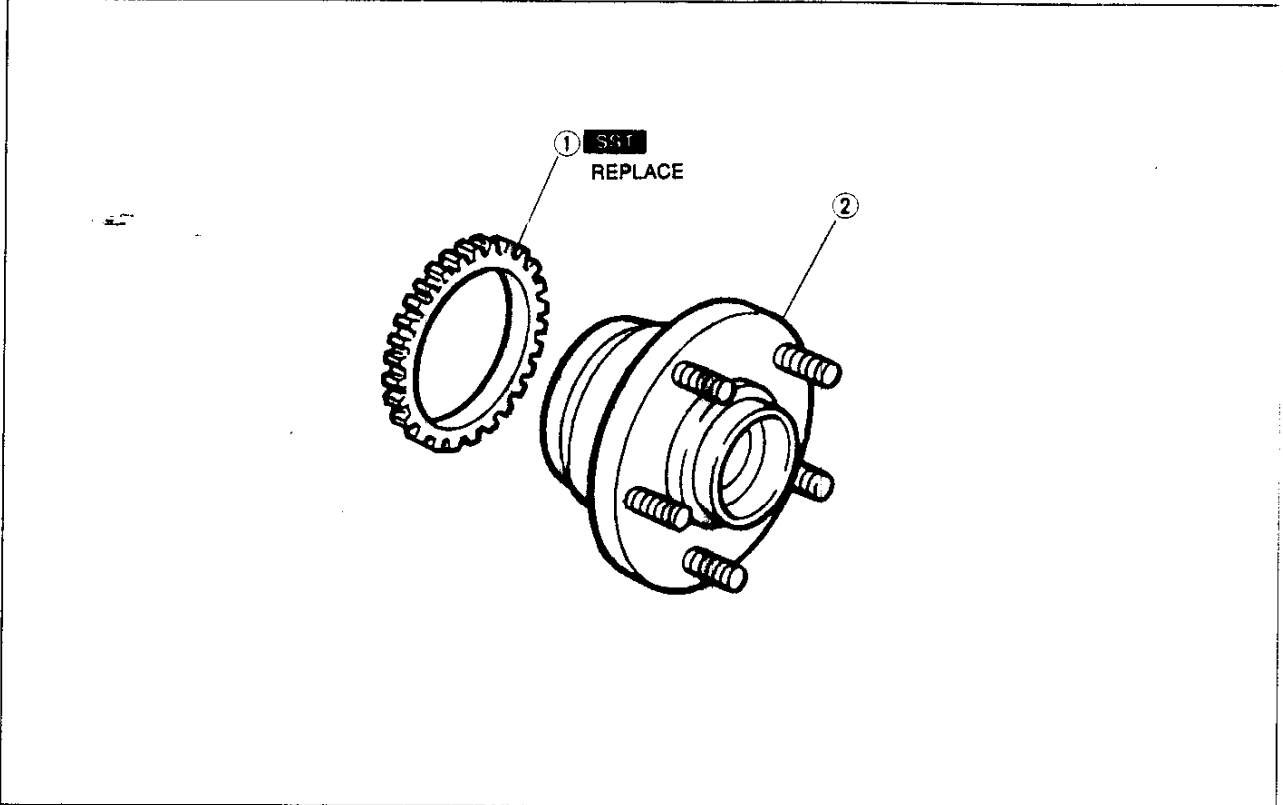

1. Sensor rotor (front)

Removal Note below
 Installation Note below

2. Front wheel hub assembly

37U0PX-096

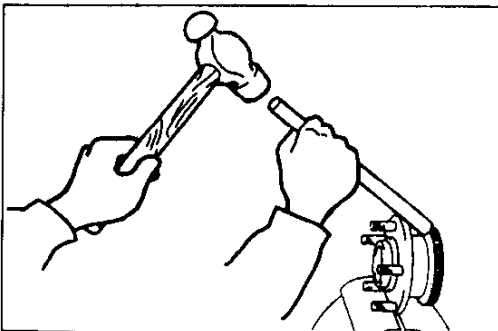

37U0PX-097

Removal note
Sensor rotor (front)

Caution

- Do not remove the sensor rotor if not necessary.
- Do not reuse the sensor rotor if removed.

Remove the sensor rotor by using a brass bar and a hammer.

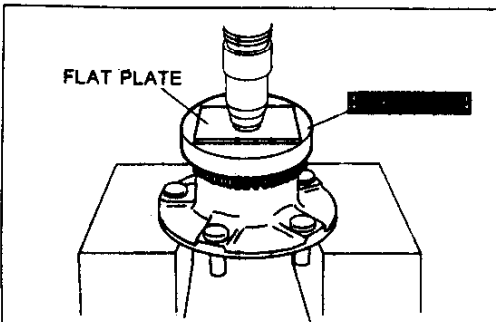

Installation note
Sensor rotor (front)

Press on the new sensor rotor by using the **SST**.

P

ANTI-LOCK BRAKE SYSTEM (ABS)

WHEEL-SPEED SENSOR (REAR)

Removal / Installation

1. Remove in the order shown in the figure.
2. Install in the reverse order of removal.

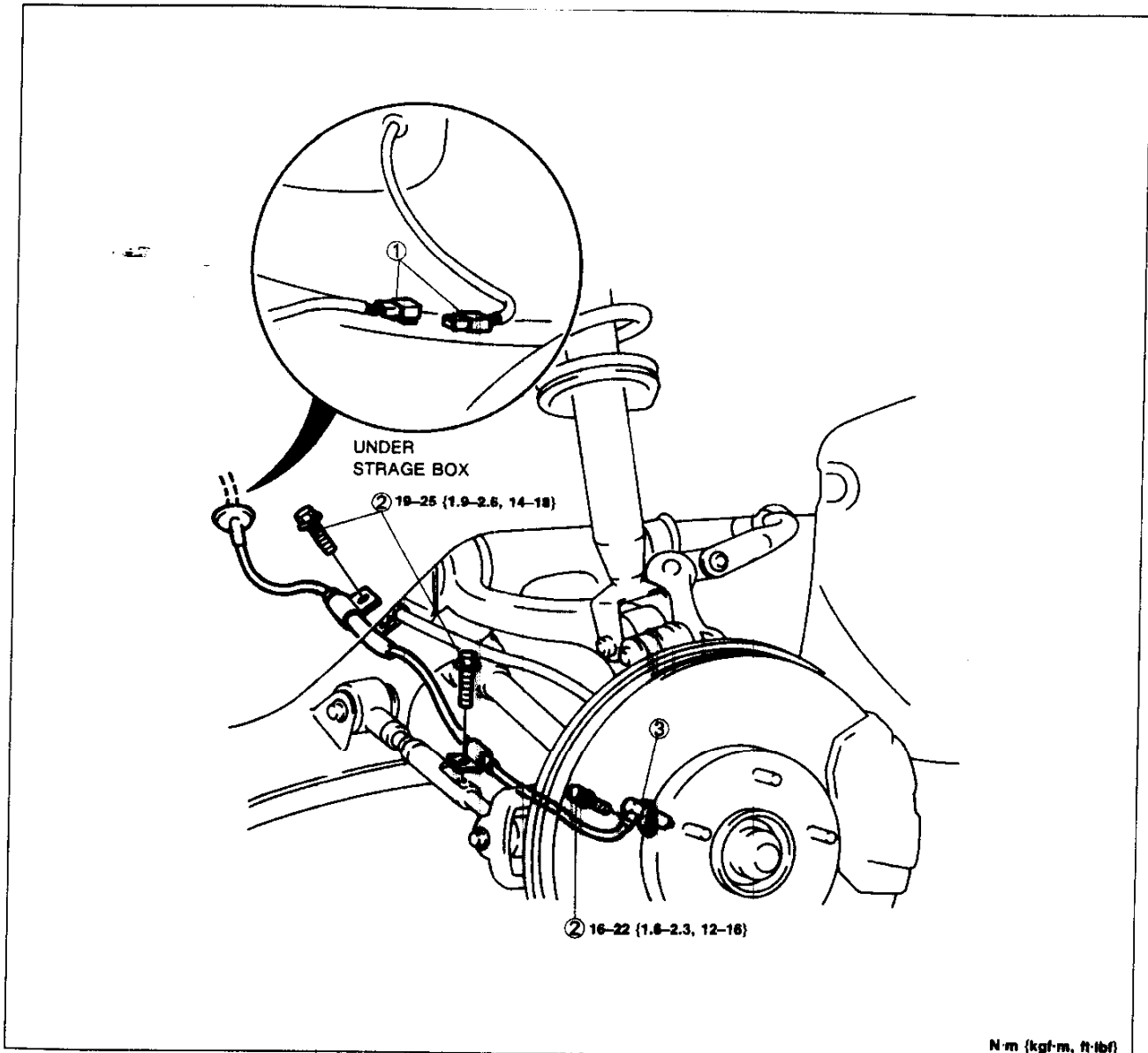

1. Connector
2. Bolt

3. Wheel-speed sensor (rear)
Inspection below

37U0PX-099

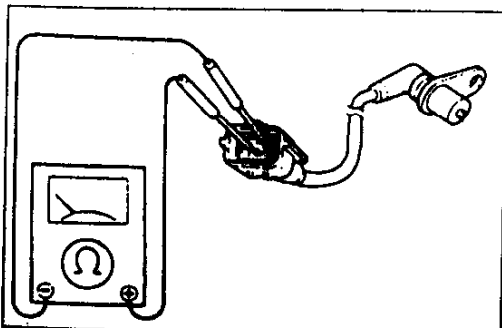

37U0PX-100

Inspection

Wheel-speed sensor (rear)

1. Measure resistance between terminals of the wheel-speed sensor.

Resistance: 0.8–1.2 k Ω

2. If resistance is not as specified, replace the wheel-speed sensor.

SENSOR ROTOR (REAR)

Removal / Installation

1. Remove the drive shaft from the vehicle. (Refer to Section M.)
2. Remove in the order shown in the figure, referring to **Removal Note**.
3. Install in the reverse order of removal, referring to **Installation Note**.
4. Install the drive shaft to the vehicle. (Refer to Section M.)

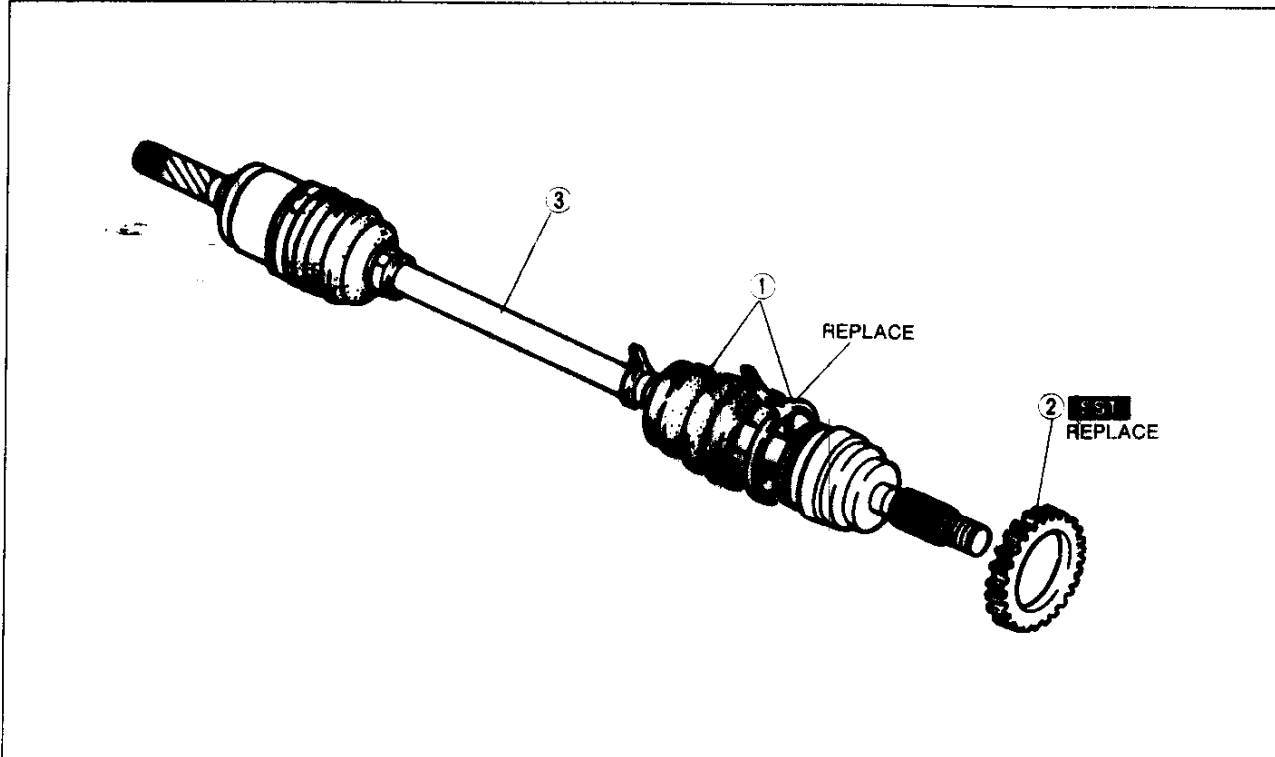

1. Boot band and boot

3. Drive shaft

37U0PX-101

2. Sensor rotor (rear)

Removal Note below

Installation Note below

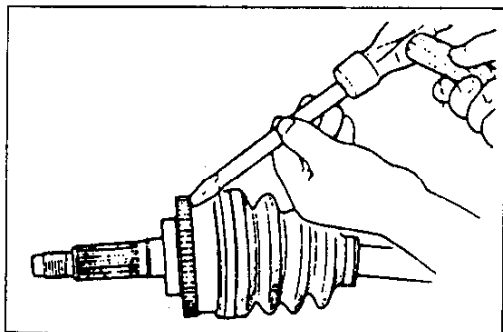

37U0PX-102

Removal note
Sensor rotor (rear)

Caution

- Do not remove the sensor rotor if not necessary.
- Do not reuse the sensor rotor if removed.

Tap the sensor rotor off the drive shaft by using a chisel and a hammer.

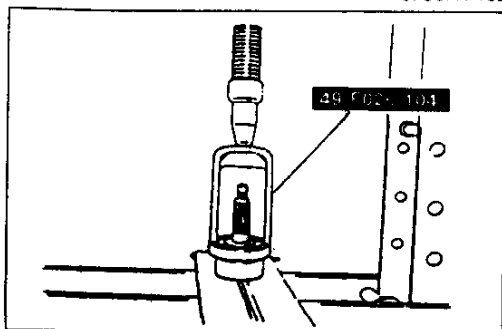

37U0PX-103

Installation note
Sensor rotor (rear)

Set a new sensor rotor on the drive shaft and press it on by using the **SST**.

RELAY

Removal / Installation

1. Disconnect the negative battery cable.
2. Remove in the order shown in the figure.
3. Install in the reverse order of removal.

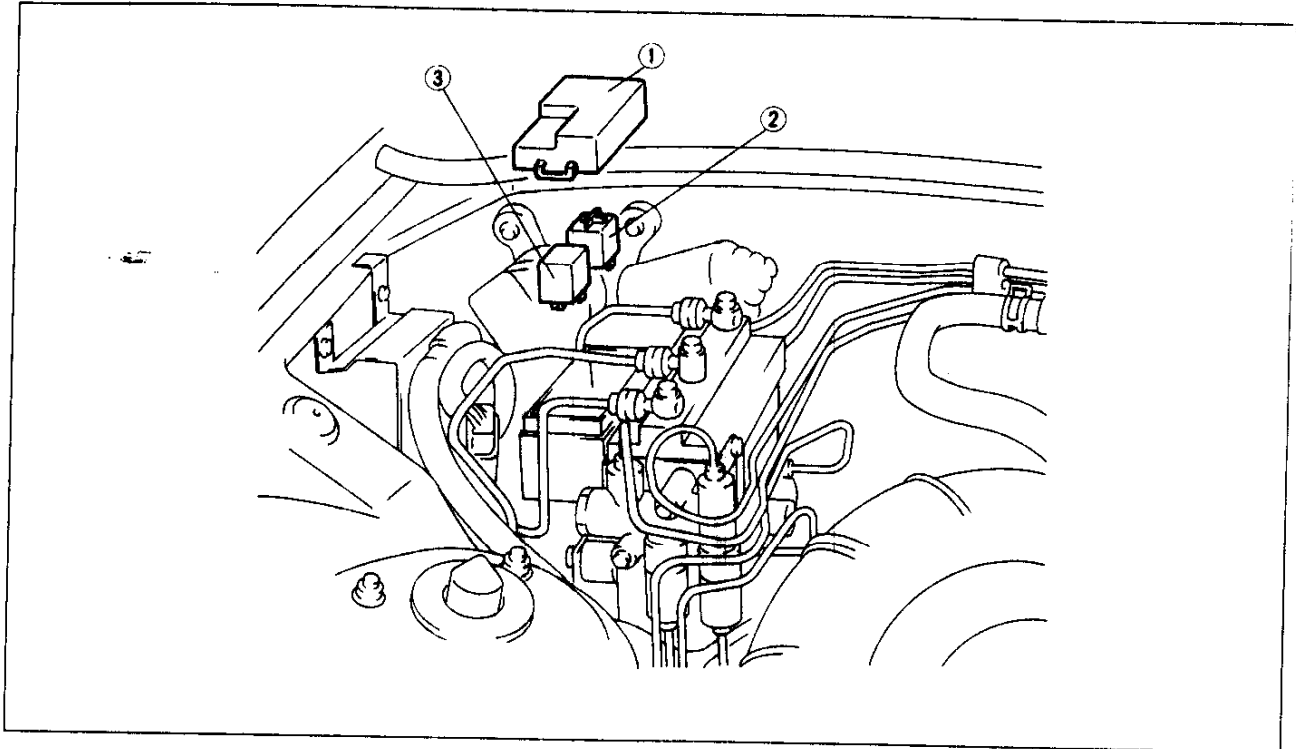

29U0PX-134

1. Cover
Inspection below
2. Motor relay
Inspection below
3. Valve relay
Inspection below

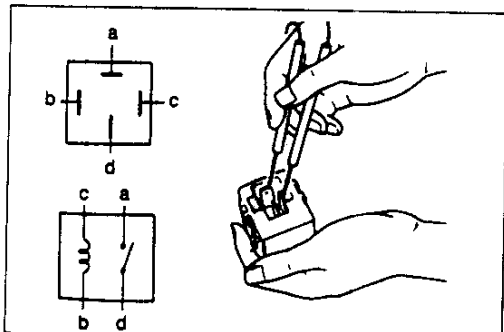

37U0PX-104

Inspection
Motor relay

1. Using an ohmmeter, check continuity between the relay terminals.

Connect to		a	b	c	d
12V	Ground				
-	-		○—○		
c	b		○—○		

○—○: Continuity

2. If continuity is not as specified, replace the motor relay.

Valve relay

1. Using an ohmmeter, check continuity between the relay terminals.

Connect to		a	b	c	d	e
12V	Ground					
-	-			○—○		
b	d		○—○		○—○	

○—○: Continuity

2. If continuity is not as specified, replace the valve relay.